

# HE-800A

パーツブック  
PARTS BOOK

---

本縫電子ボタン穴かがりミシン  
ELECTRONIC LOCKSTITCH BUTTON HOLDER

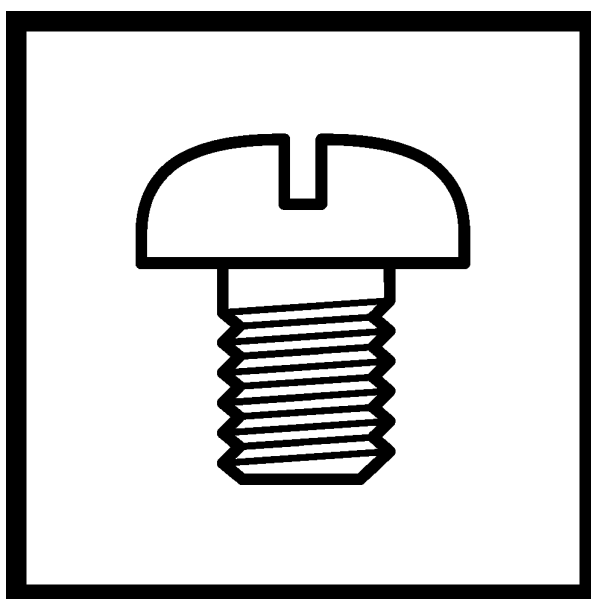

---

**brother**<sup>®</sup>

最新の部品情報は Parts Navigation でご覧いただけます。 <http://partsbook.brother.co.jp/partsnavi/jpn/>  
The latest parts information, refer to the Parts Navigation. <http://partsbook.brother.co.jp/partsnavi/eng/>

# パーツブックご利用に際して

1. この本は、2007年11月のデータに基づいて作成されたものです。
2. 部品は予告なしに設計変更される場合があります。
3. 組単位で補給する部品は、破線で示してあります。

## 目 次

A. 主体関係 .....	1
B. 針棒・天秤関係 .....	3
C. 上軸関係 .....	5
D. 針振り関係 .....	7
E. 非常停止関係 .....	9
F. 押え関係 .....	11
G. 送り関係 .....	13
H. カッター関係 .....	17
J. 糸切れ感知関係 .....	19
K. かま関係 .....	21
L. 下軸関係 .....	23
M. 給油潤滑関係 .....	25
N. 糸通し関係 .....	29
P. 糸巻関係 .....	33
Q. 上糸切り関係 .....	35
R. 下糸切り関係 .....	37
S. 針位置検出器関係 .....	41
T1. コントロールボックス関係 .....	43
T2. コントロールボックス関係 .....	45
T3. コントロールボックス関係(電源基板) .....	47
U. 電装品関係 .....	49
V. 操作パネル関係 .....	51
W. モータ関係 .....	53
X. カバー関係 .....	55
Y. 付属装置関係(オプション部品) .....	57
Z1. 付属品関係 .....	59
Z2. 付属品関係 .....	61
Z3. 付属品関係 .....	63
Ga1. ゲージ部品一覧表 .....	65
Ga2. ゲージ部品一覧表 .....	66
Ga3. ゲージ部品一覧表 .....	67
Wa. 警告ラベル .....	68
索引 .....	69

# Notes for using this parts book

1. This book was prepared based on information available in November 2007.
2. Parts are subject to changes in design without prior notice.
3. Parts supplied as complete assemblies are circled by a dotted line.

## CONTENTS

A. Machine body .....	1
B. Needle bar and thread take-up mechanism .....	3
C. Upper shaft mechanism .....	5
D. Zigzag mechanism .....	7
E. Emergency stop mechanism .....	9
F. Presser foot mechanism .....	11
G. Feed mechanism .....	13
H. Cutter mechanism .....	17
J. Thread breakage detector mechanism .....	19
K. Rotary hook mechanism .....	21
L. Lower shaft mechanism .....	23
M. Lubrication .....	25
N. Threading mechanism .....	29
P. Bobbin winder mechanism .....	33
Q. Upper thread trimmer mechanism .....	35
R. Lower thread trimmer mechanism .....	37
S. Synchronizer .....	41
T1. Control box mechanism .....	43
T2. Control box mechanism .....	45
T3. Control box (PCB) mechanism .....	47
U. Power supply equipment mechanism .....	49
V. Operation panel mechanism .....	51
W. Motor mechanism .....	53
X. Safety cover .....	55
Y. Attachment set (Option parts) .....	57
Z1. Accessories .....	59
Z2. Accessories .....	61
Z3. Accessories .....	63
Ga1. Gauge parts list .....	65
Ga2. Gauge parts list .....	66
Ga3. Gauge parts list .....	67
Wa. Warning labels .....	68
Index .....	69

A . 主体関係 / Machine body

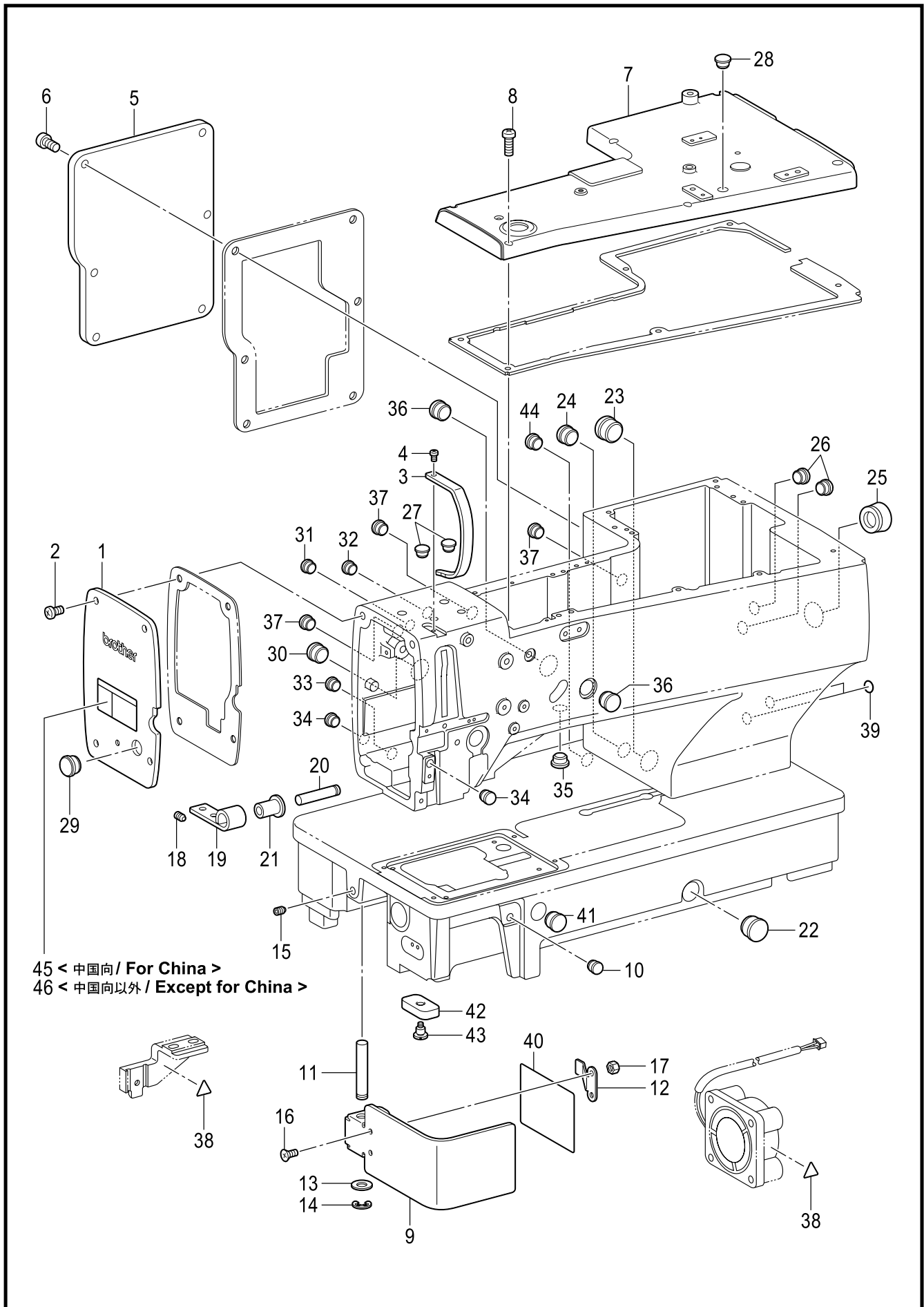

HE-800A-050

A. 主体関係 / Machine body

REF.NO	CODE	Q'TY	品名	NAME OF PARTS	RM
1	S50124001	1	メンイタ	FACE PLATE	
2	062711012	4	ナベコ476-32X10	SCREW PAN SM4.76-32X10	
3	SA4206001	1	テンピンカバー	THREAD TAKE-UP LEVER COVER	
4	062680612	1	ナベコ437-40X6	SCREW PAN SM4.37-40X6	
5	S50126001	1	ガワイタ	REAR COVER	
6	062711012	6	ナベコ476-32X10	SCREW PAN SM4.76-32X10	
7	S50127101	1	ウフフタ	TOP COVER	
8	062711612	6	ナベコ476-32X16	SCREW PAN SM4.76-32X16	
9	S50128201	1	カマカバー	ROTARY HOOK COVER	
10	104450101	1	ゴムセン8	RUBBER CAP, 8	
11	158879001	1	カマカバージク	SHAFT, ; R-HOOK COVER	
12	S00306001	1	ヒンジイタバネ	HINGE PLATE SPRING	
13	025080132	1	ヒラザガネシヨウ8	WASHER PLAIN S 8	
14	048060342	1	トメワE6	RETAINING RING E6	
15	014760632	1	アナクボミ595-28X6	SET SCREW SOCKET SM5.95-28X6	
16	117143003	2	サラネジ4.37	SCREW, FLAT SM4.37	
17	021680202	2	2シュナット437-40	NUT 2 SM4.37-40	
18	014760632	2	アナクボミ595-28X6	SET SCREW SOCKET SM5.95-28X6	
19	158830001	2	ヒンジ	BED HINGE	
20	158831001	2	ヒンジピン	PIN	
21	158832000	2	ヒンジピンササエゴム	PIN SUPPORT RUBBER	
22	159150000	1	ゴムセン20.5	RUBBER CAP, 20.5	
23	159150000	1	ゴムセン20.5	RUBBER CAP, 20.5	
24	104449001	1	ゴムセン15.5	RUBBER CAP, 15.5	
25	104451101	1	ゴムセン23.9	RUBBER CAP, 23.9	
26	104450101	2	ゴムセン8	RUBBER CAP, 8	
27	104450101	2	ゴムセン8	RUBBER CAP, 8	
28	104450101	1	ゴムセン8	RUBBER CAP, 8	
29	104449001	1	ゴムセン15.5	RUBBER CAP, 15.5	
30	104449001	1	ゴムセン15.5	RUBBER CAP, 15.5	
31	104450101	1	ゴムセン8	RUBBER CAP, 8	
32	104450101	1	ゴムセン8	RUBBER CAP, 8	
33	104450101	1	ゴムセン8	RUBBER CAP, 8	
34	104450101	2	ゴムセン8	RUBBER CAP, 8	
35	104450101	1	ゴムセン8	RUBBER CAP, 8	
36	104449001	2	ゴムセン15.5	RUBBER CAP, 15.5	
37	S32263001	3	ゴムセン8.5	RUBBER CAP, 8.5	
38	S36924001	2	ワーニングマーク	INJURY MARK	
39	S37060001	2	アースマーク	LABEL, GROUNDING	
40	S50131001	1	イトオシセツメイイタ	THREADING DIAGRAM	
41	104449001	1	ゴムセン15.5	RUBBER CAP, 15.5	
42	S50340000	2	ベットダイクツシヨウ	BED BASE CUSHION	
43	120263001	2	ダンネジ4.37	SHOULDER SCREW, SM4.37	
44	117936001	1	ゴムセン9.4	RUBBER CAP, 9.4	
45	SA0793001	1	<中国向> ラベルチュウウイ.チュウエイ	<For China> LABEL CAUTION CHN/ENG	
46	SA0792001	1	<中国向以外> ラベルチュウウイ.ワイ	<Except for China> LABEL CAUTION JPN/ENG	

B. 針棒・天秤關係 / Needle bar and thread take-up mechanism

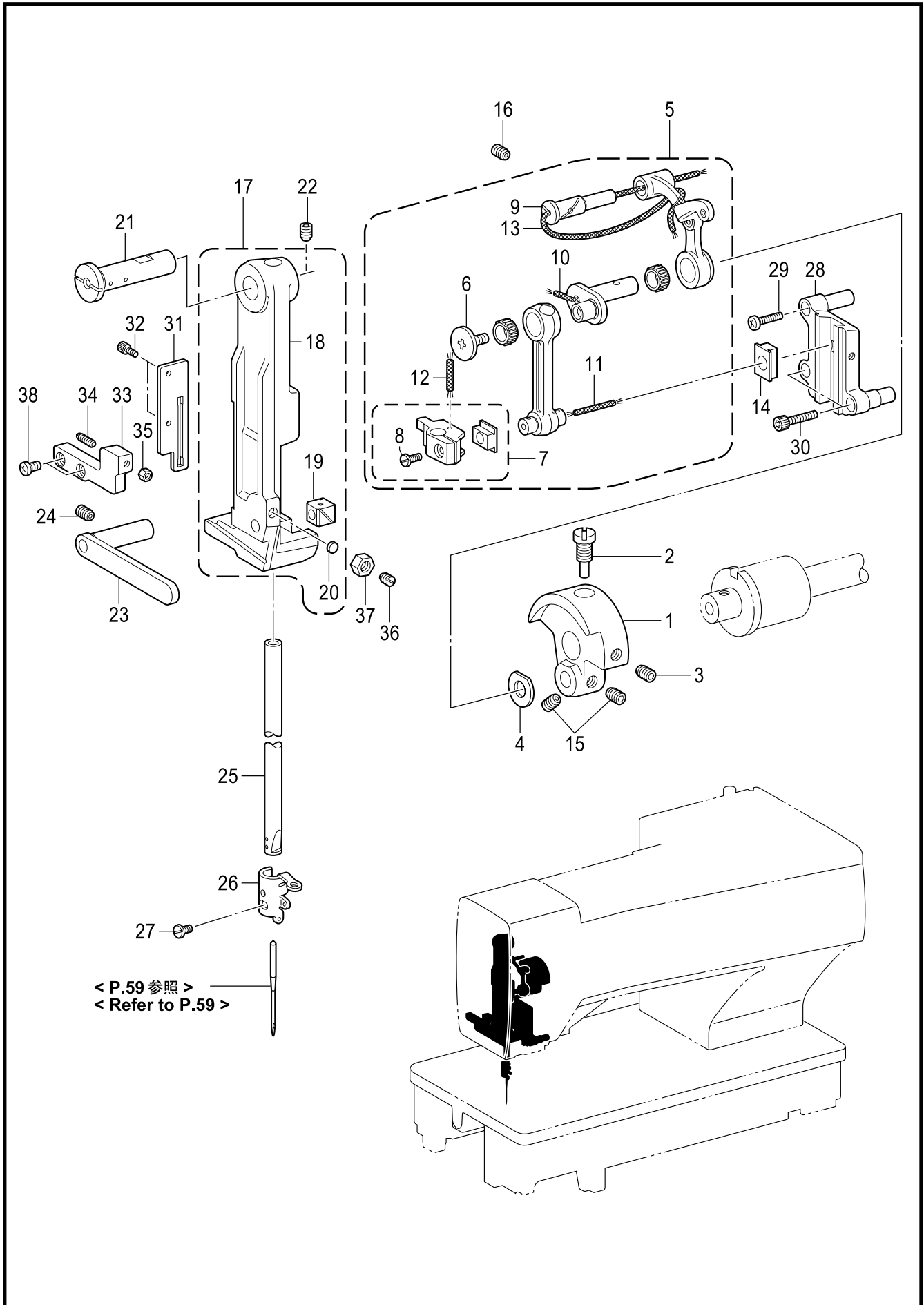

B. 針棒・天秤関係 / Needle bar and thread take-up mechanism

REF.NO	CODE	Q'TY	品名	NAME OF PARTS	RM
1	S50132000	1	テンピンクランク	THREAD TAKE-UP CRANK	
2	100250001	1	シメネジ7.14	SCREW, SM7.14	
3	014770632	1	アナクボミ635-40X6	SET SCREW SOCKET SM6.35-40X6	
4	110367001	1	ザガネ	WASHER, PLAIN SPECIAL 8	
5	SA4047301	1	ハリボウレンカンオオクミ	NEEDLE BAR CONNECTING ROD SET	
6	145465001	1	シメネジ3.57L	SCREW, SM3.57-40X6 L	
7	S50136101	1	ハリボウダキソウクミ	NEEDLE BAR CLAMP SET	
8	140004001	1	シメネジ3.57	SCREW, SM3.57-40X7	
9	S52943101	1	テンピンササエジク	SUPPORT SHAFT	
10	140430001	1	クミヒモ3X40	WICK, 3X40	
11	S50271000	1	クミヒモ2X35	WICK, 2X35	
12	S50272000	1	クミヒモ3X15	WICK, 3X15	
13	S50142000	1	クミヒモ3X290	WICK, 3X290	
14	S52248001	1	ハリボウアンナイカクコマ	N-BAR BRACKET SLIDE BLOCK	
15	014770632	2	アナクボミ635-40X6	SET SCREW SOCKET SM6.35-40X6	
16	014760632	1	アナクボミ595-28X6	SET SCREW SOCKET SM5.95-28X6	
17	S50143001	1	ハリボウダイソウクミ	NEEDLE BAR BRACKET SET	
18	S50144001	1	ハリボウダイクミ	NEEDLE BAR BASE ASSY	
19	159624001	1	ハリボウダイカクコマ	N-BAR BRACKET SLIDE BLOCK	
20	S50146001	1	ストツパイタ	STOPPER PLATE	
21	158888001	1	ハリボウダイササエジク	N-BAR BASE SUPPORT SHAFT	
22	014760632	1	アナクボミ595-28X6	SET SCREW SOCKET SM5.95-28X6	
23	S50147001	1	ハリボウダイアンナイ	NEEDLE BAR BASE GUIDE	
24	014760632	1	アナクボミ595-28X6	SET SCREW SOCKET SM5.95-28X6	
25	SA2921101	1	ハリボウ	NEEDLE BAR	
26	S50149101	1	ハリボウイトアンナイ	NEEDLE BAR THREAD GUIDE	
27	140553102	1	アタマツキトメネジ3.18	SET SCREW, SM3.18	
28	S50150001	1	クランクロツドアンナイ	CRANK ROD GUIDE	
29	S31808001	1	ナベコ437-40X25	SCREW, PAN SM4.37-40X25	
30	150382001	2	アナボルト4.37X18	BOLT, SOCKET SM4.37X18	
31	S50152001	1	ハリボウアンナイ	NEEDLE BAR GUIDE	
32	154965001	2	アナボルト3.57X8	BOLT, SOCKET SM3.57X8	
33	S50153101	1	ハリボウダイストツパ	STOPPER	
34	153483001	1	トメネジ4.76	SET SCREW, SM4.76	
35	021710202	1	2シュナット476-32	NUT 2 SM4.76-32	
36	013761410	1	トメクボミ595-28X14	SET SCREW (CP) SM5.95-28X14	
37	100022005	1	ナツト5.95	NUT, SM5.95	
38	062681012	2	ナベコ437-40X10	SCREW PAN SM4.37-40X10	

C . 上軸関係 / Upper shaft mechanism

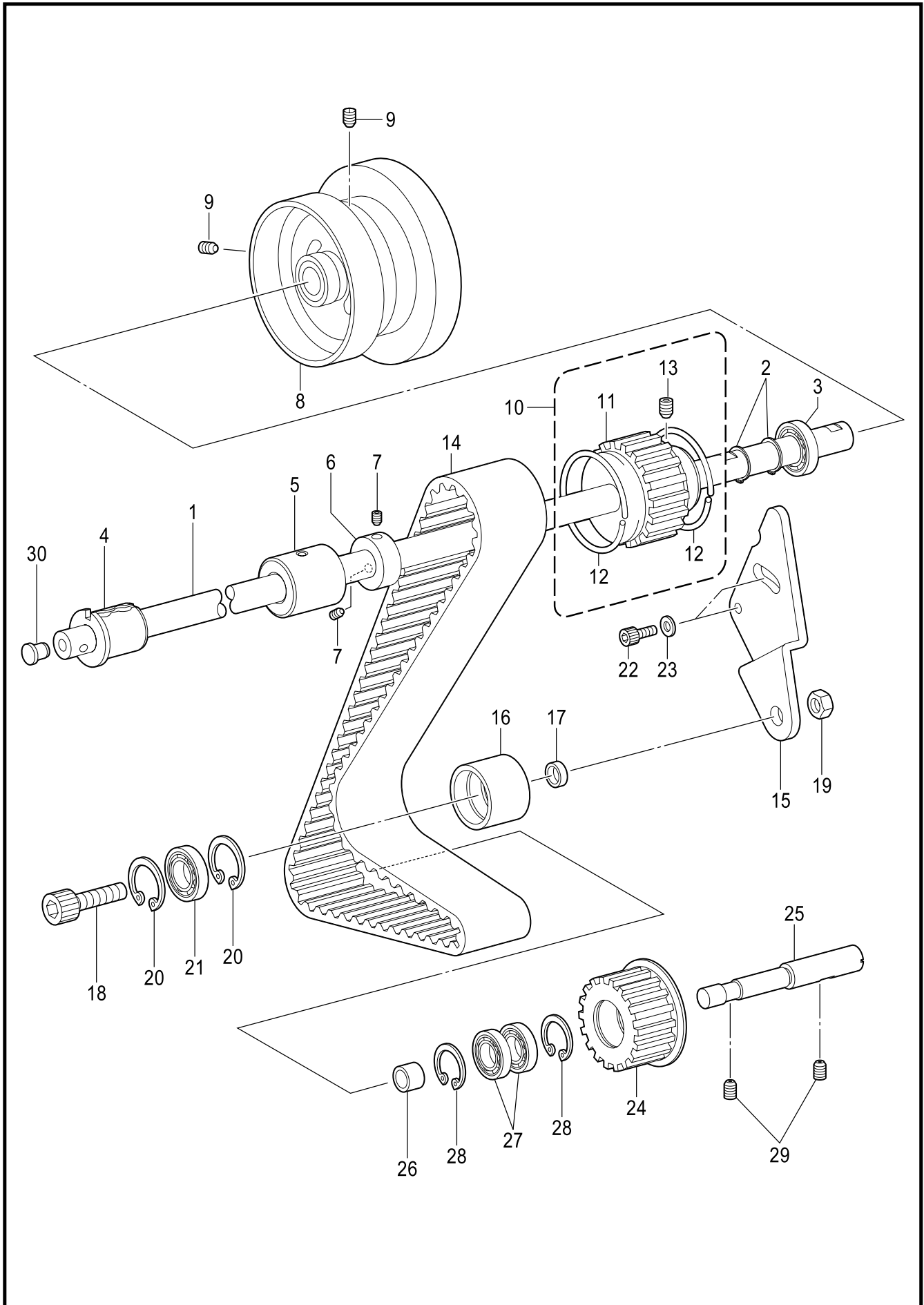

HE-800A-109



C. 上軸関係 / Upper shaft mechanism

REF.NO	CODE	Q'TY	品名	NAME OF PARTS	RM
1	S50154001	1	ウワジク	UPPER SHAFT	
2	048150142	2	トメワジクヨウC15	RETAINING RING EXTERNAL C15	
3	072630260	1	Tタマジクウケ6302VV	BALL BEARING, THRUST 6302VV	
4	SA4065001	1	ウワジクメタルF	BUSH, F	
5	158893100	1	ウワジクメタルM	BUSH M	
6	S50156001	1	セットカラー	SET SCREW COLLAR	
7	014780632	2	アナクボミ635-28X6	SET SCREW SOCKET SM6.35-28X6	
8	S50157001	1	プ-リクミ	PULLEY ASSY	
9	014760632	2	アナクボミ595-28X6	SET SCREW SOCKET SM5.95-28X6	
10	S50159001	1	タイミングプ-リUクミ	T-PULLEY ASSY, U	
11	S50160001	1	タイミングプ-リU	T-PULLEY, U	
12	S48034001	2	タイミングプ-リリング	RING	
13	014780632	2	アナクボミ635-28X6	SET SCREW SOCKET SM6.35-28X6	
14	S50161000	1	タイミングベルト	TIMMING BELT	
15	S50163001	1	テンションプ-リイタ	TENSION PULLEY PLATE	
16	S50164001	1	テンションプ-リ	TENSION PULLEY	
17	S50165001	1	テンションプ-リカラー	COLLAR	
18	018102536	1	アナボルト10X25	BOLT SOCKET M10X25	
19	021100302	1	3シュナット10	NUT 3 M10	
20	048300242	2	トメワアナヨウC30	RETAINING RING INTERNAL C30	
21	076200800	1	Rタマジクウケ6200ZZ	BALL BEARING RADIAL 6200ZZ	
22	018061632	2	アナボルト6X16	BOLT SOCKET M6X16	
23	025060232	2	ヒラザガネネチュウ6	WASHER PLAIN M 6	
24	S50166001	1	アイドルプ-リ	IDLER PULLEY	
25	S50167001	1	アイドルプ-リジク	SHAFT	
26	S50168001	1	アイドルプ-リカラー	COLLAR	
27	070608800	2	Rタマジクウケ608ZZ	BALL BEARING RADIAL 608ZZ	
28	048220242	2	トメワアナヨウC22	RETAINING RING INTERNAL C22	
29	014760632	2	アナクボミ595-28X6	SET SCREW SOCKET SM5.95-28X6	
30	111865009	1	セン6	CAP, 6	

D . 針振り関係 / Zigzag mechanism

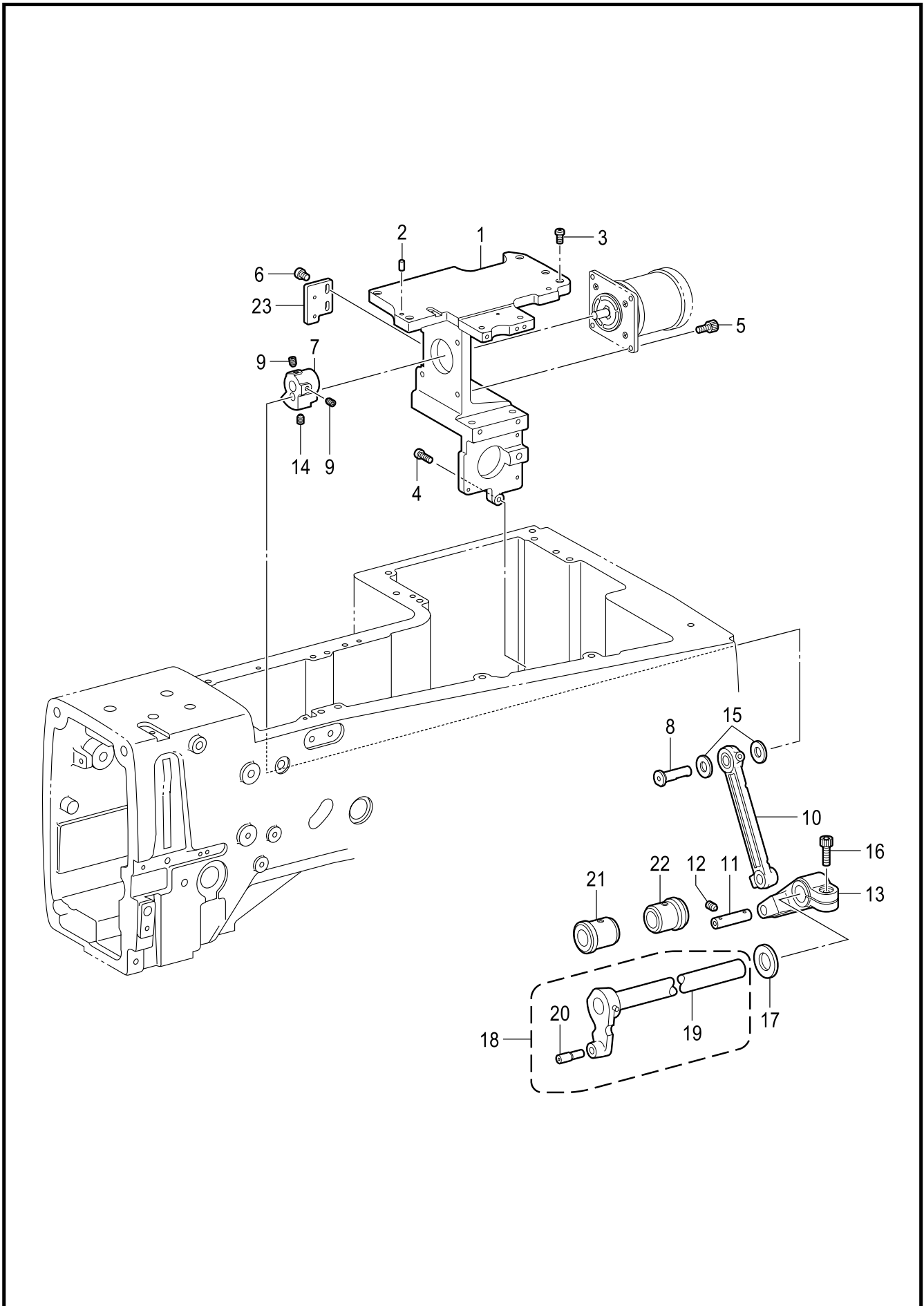

HE-800A-110

D. 針振り関係 / Zigzag mechanism

REF.NO	CODE	Q'TY	品名	NAME OF PARTS	RM
1	S50169001	1	モータブラケット	MOTOR BRACKET	
2	S37940001	2	イチギメピン	POSITIONING PIN	
3	062711212	4	ナベコ476-32X12	SCREW PAN SM4.76-32X12	
4	062711612	1	ナベコ476-32X16	SCREW PAN SM4.76-32X16	
5	018401232	4	アナボルト4X12	BOLT SOCKET M4X12	
6	060300612	2	バインド3X6	SCREW BIND M3X6	
7	SA2881001	1	モータレバー	MOTOR LEVER	
8	S50171001	1	モータレバージク	MOTOR LEVER SHAFT	
9	014760632	2	アナクボミ595-28X6	SET SCREW SOCKET SM5.95-28X6	
10	S50172001	1	ハリフリレンカン	ZIGZAG CONNECTING ROD	
11	S51190001	1	ハリフリレンカンジク	Z-CONNECTING ROD SHAFT	
12	014760632	1	アナクボミ595-28X6	SET SCREW SOCKET SM5.95-28X6	
13	S50174001	1	ハリフリレバー	ZIGZAG LEVER	
14	014760632	1	アナクボミ595-28X6	SET SCREW SOCKET SM5.95-28X6	
15	118735001	2	ザガネ	WASHER	
16	018062032	1	アナボルト6X20	BOLT SOCKET M6X20	
17	S32521001	1	スラストザガネ	WASHER, THRUST	
18	S50176001	1	ハリフリレバー-Fクミ	ZIGZAG LEVER ASSY, F	
19	S50178001	1	ハリフリレバージク	Z-LEVER SHAFT	
20	159625001	1	レバー-Fカクコマジク	STUD	
21	158945001	1	ハリフリジクメタルF	BUSH, F ; Z-LEVER	
22	158946001	1	ハリフリジクメタルR	BUSH, R ; Z-LEVER	
23	S50179001	1	ハリフリセンサイタ	Z-SENSOR PLATE	

E . 非常停止關係 / Emergency stop mechanism

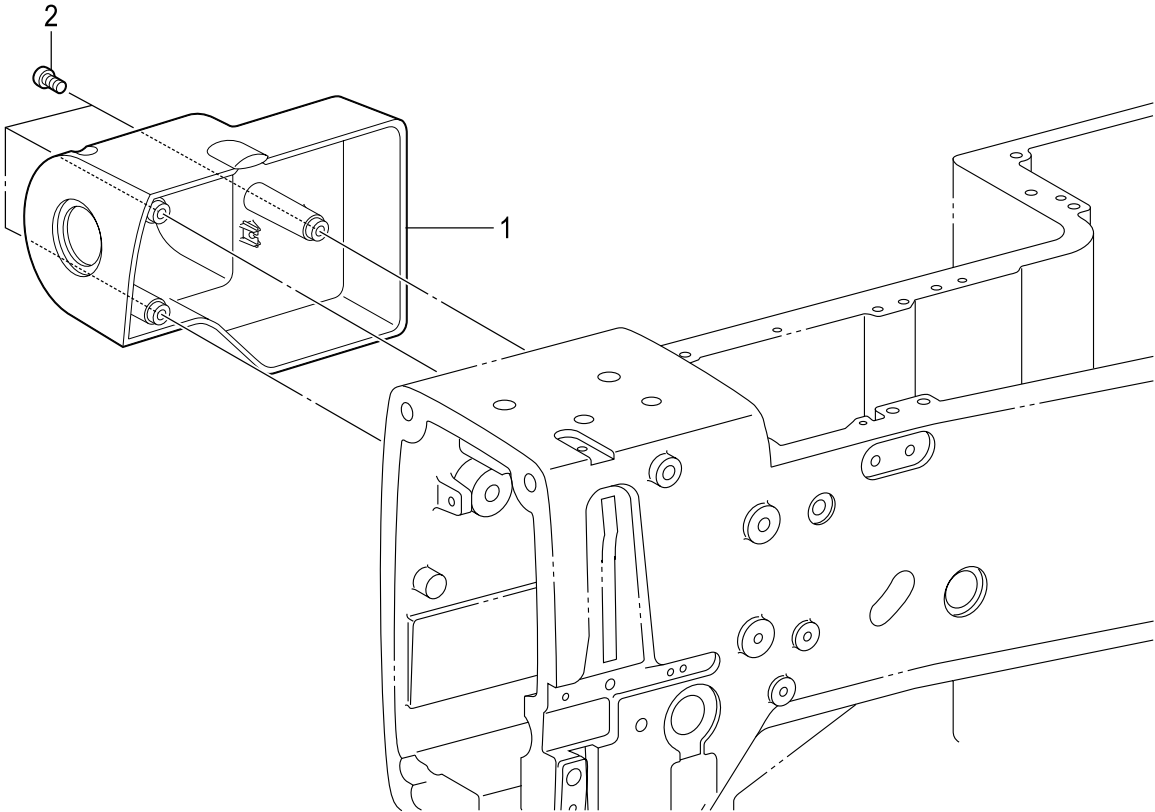

E. 非常停止関係 / Emergency stop mechanism

REF.NO	CODE	Q'TY	品名	NAME OF PARTS	RM
1	S50182000	1	ヒジヨウテイシカバ-	EMERGENCY STOP COVER	
2	062400806	3	ナベコ4X8	SCREW PAN M4X8	

F . 押え関係 / Presser foot mechanism

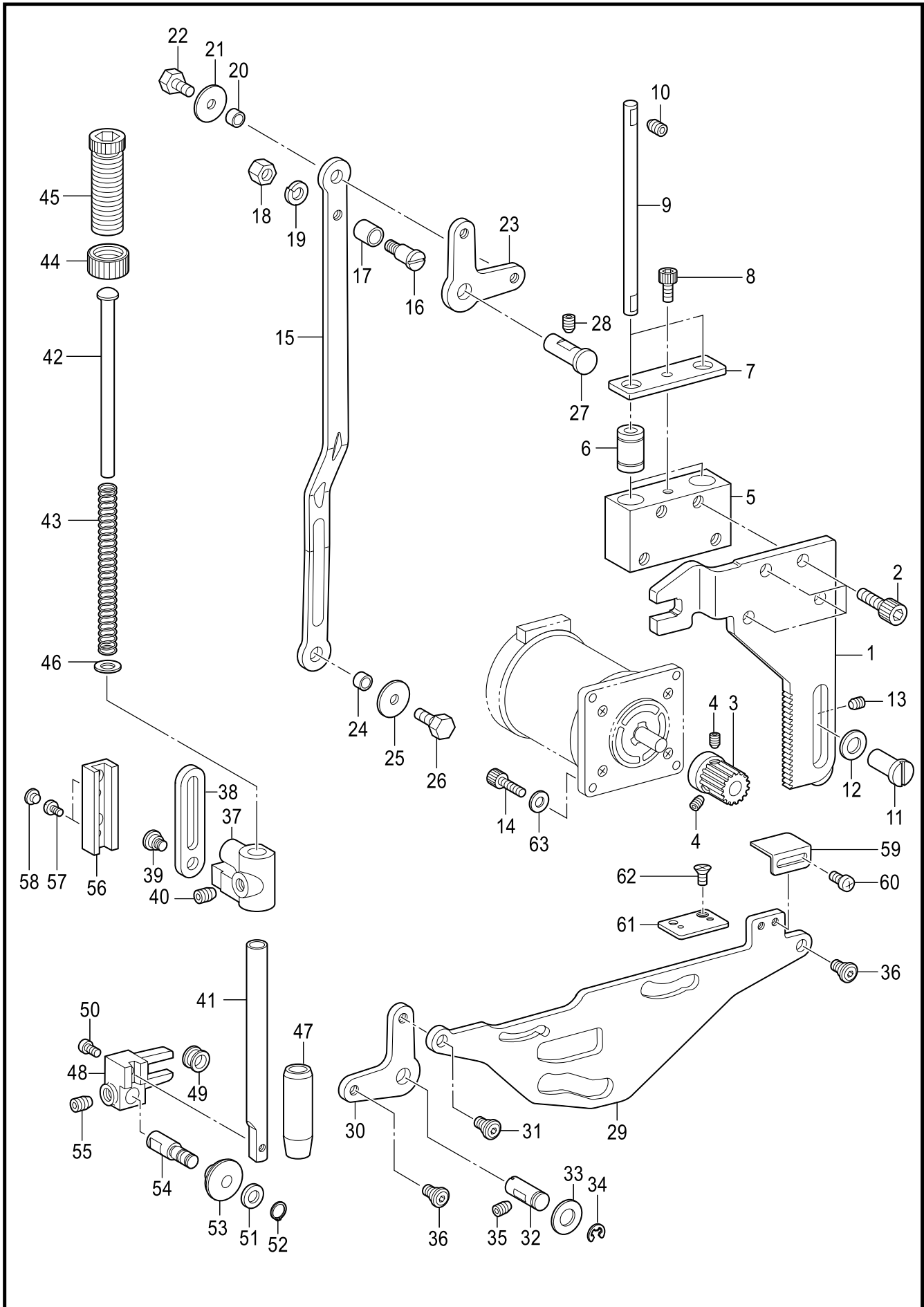

HE-800A-201

F. 押え関係 / Presser foot mechanism

REF.NO	CODE	Q'TY	品名	NAME OF PARTS	RM
1	S50183001	1	オサエドウウデ	PRESSER DRIVING ARM	
2	018061032	4	アナボルト6X10	BOLT SOCKET M6X10	
3	S43717201	1	クドウギヤ15.75	GEAR, 15.75	
4	014770632	2	アナクボミ635-40X6	SET SCREW SOCKET SM6.35-40X6	
5	S50184001	1	オサエドウアンナイダイ	GUIDE BRACKET	
6	S42116000	2	リニアブツシュ	LINEAR BUSH	
7	S50185001	1	ベアリングオサエ	BEARING HOLDER	
8	018400832	1	アナボルト4X8	BOLT SOCKET M4X8	
9	S50186001	2	アンナイジク	GUIDE SHAFT	
10	014760632	4	アナクボミ595-28X6	SET SCREW SOCKET SM5.95-28X6	
11	S50187001	1	クドウウデオサエ	DRIVING ARM PRESSER	
12	110367001	1	ザガネ	WASHER, PLAIN SPECIAL 8	
13	014760632	1	アナクボミ595-28X6	SET SCREW SOCKET SM5.95-28X6	
14	018401232	3	アナボルト4X12	BOLT SOCKET M4X12	
15	S50189001	1	オサエアゲレンカン	P-LOFTER CONNECTING ROD	
16	S50190001	1	オサエレンカンダンネジ	SHOULDER SCREW	
17	S50191001	1	レンカンコロ	ROLLER	
18	110161004	1	ナツト4.76	NUT, SM4.76	
19	028050242	1	バネザガネ2-5	WASHER SPRING 2-5	
20	S50192101	1	オサエアゲカンザ	SPACER	
21	SA3001001	1	メスサドウレバザガネD	WASHER, PLAIN L 4.8: D	
22	117363001	1	ボルト4.76	BOLT, SM4.76	
23	S38761201	1	ヒザアゲレバー	LIFTER LEVER KNEE	
24	S50192101	1	オサエアゲカンザ	SPACER	
25	SA3001001	1	メスサドウレバザガネD	WASHER, PLAIN L 4.8: D	
26	117363001	1	ボルト4.76	BOLT, SM4.76	
27	S50193001	1	オサエアゲレバー-ジクA	LIFTER SHAFT, A	
28	014760632	1	アナクボミ595-28X6	SET SCREW SOCKET SM5.95-28X6	
29	S50195001	1	ウワイトキリクドウリンク	U-THREAD TRIMMER DRIVING LINK	
30	S38761201	1	ヒザアゲレバー	LIFTER LEVER KNEE	
31	145478101	1	ダンネジ4.76	SHOULDER SCREW, SOCKET SM4.76	
32	S50196001	1	オサエアゲレバー-ジク	LIFTER SHAFT	
33	025080132	1	ヒラザガネシヨウ8	WASHER PLAIN S 8	
34	048060342	1	トメワE6	RETAINING RING E6	
35	014760632	1	アナクボミ595-28X6	SET SCREW SOCKET SM5.95-28X6	
36	145478101	2	ダンネジ4.76	SHOULDER SCREW, SOCKET SM4.76	
37	S50198001	1	オサエボウダキ	PRESSER BAR GUIDE BRACKET	
38	S50199101	1	オサエアゲリンク	PRESSER BAR LINK	
39	145478101	1	ダンネジ4.76	SHOULDER SCREW, SOCKET SM4.76	
40	014760632	1	アナクボミ595-28X6	SET SCREW SOCKET SM5.95-28X6	
41	111466121	1	オサエボウ	PRESSER BAR	
42	SA7607001	1	オサエバネアンナイ	SPRING GUIDE	
43	S50200001	1	オサエバネ	PRESSER BAR SPRING	
44	S31013001	1	チヨウセツネジツマミナツト	PRESSER ADJUSTING NUT	
45	S31012001	1	オサエチヨウセツネジ	PRESSER ADJUSTING SCREW	
46	140407001	1	ザガネ	WASHER	
47	145472001	1	オサエボウメタル	PRESSER BAR BUSH	
48	S50201001	1	オサエロ-ラタイ	P-BAR ROLLER BRACKET	
49	S50202001	1	ハサミササエジクコロ	ROLLER	
50	062671212	1	ナベコ357-40X12	SCREW PAN SM3.57-40X12	
51	025060132	1	ヒラザガネシヨウ6	WASHER PLAIN S 6	
52	048060142	1	トメワジクヨウC6	RETAINING RING EXTERNAL C6	
53	S50203101	1	オサエコロ	ROLLER	
54	S50204001	1	オサエコロジク	ROLLER SHAFT	
55	014760632	1	アナクボミ595-28X6	SET SCREW SOCKET SM5.95-28X6	
56	S37927000	1	ハリボウアンナイ	NEEDLE BAR GUIDE	
57	100242003	2	シメネジ3.57	SCREW, SM3.57-40X5	
58	155578000	2	ゴムセン7.2	RUBBER CAP, 7.2	
59	S50205001	1	オサエセンサー-ドグ	CLAMP SENSOR DOG	
60	060670512	2	バインド357-40X5	SCREW BIND SM3.57-40X5	
61	S50206001	1	オサエセンサー-イタ	CLAMP SENSORPLATE	
62	102538002	1	サラネジ3.57	SCREW, FLAT SM3.57	
63	025040232	3	ヒラザガネチュウ4	WASHER PLAIN M 4	

HE-800A-201

G . 送り関係 / Feed mechanism

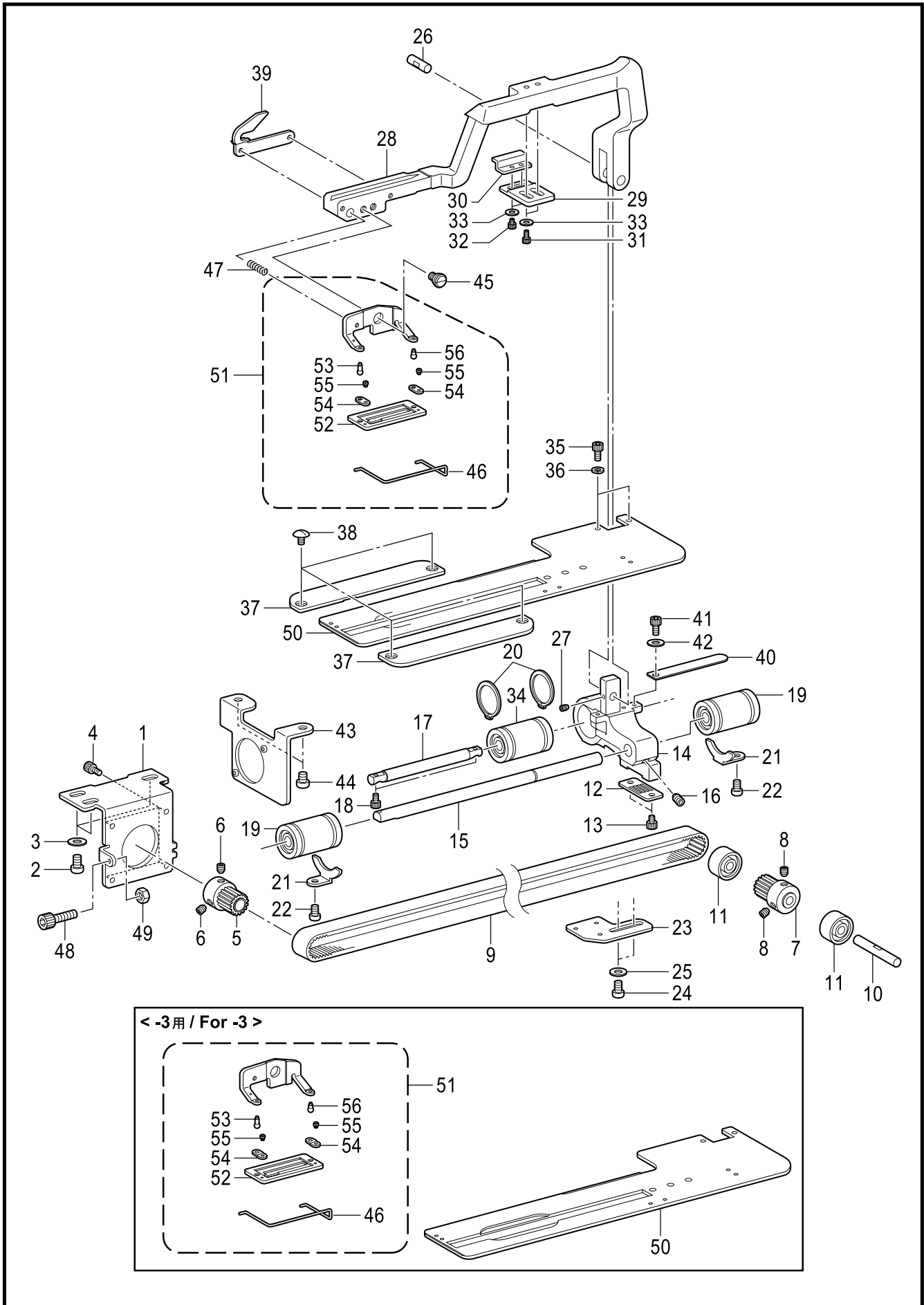



## G. 送り関係 / Feed mechanism

REF.NO	CODE	Q'TY	品名	NAME OF PARTS	RM
1	S50207001	1	モータササエイタ	MOTOR MOUNTING BRACKET	
2	062761012	3	ナベコ595-28X10	SCREW PAN SM5.95-28X10	
3	025060232	3	ヒラザガネチュウ6	WASHER PLAIN M 6	
4	018401032	4	アナボルト4X10	BOLT SOCKET M4X10	
5	S50208001	1	オクリクドゥブ-リA	PULLEY, A	
6	014060632	2	アナクボミ6X6	SET SCREW SOCKET (CP) M6X6	
7	S50110001	1	オクリクドゥブ-リB	PULLEY, B	
8	014060632	2	アナクボミ6X6	SET SCREW SOCKET (CP) M6X6	
9	S50209000	1	オクリタイミングベルト	TIMING BELT	
10	S50210001	1	オクリプ-リササエジク	SUPPORT SHAFT	
11	070688850	2	Rタマジクウケ688ZZ	BALL BEARING RADIAL 688ZZ	
12	S50211101	1	オクリベルトホルダ	BELT HOLDER	
13	S59890001	2	アナボルト437-40X8	BOLT, SOCKET SM4.37-40X8	
14	S50212001	1	オクリウデササエダイ	FEED ARM SUPPORT	
15	S50213001	1	オクリアンナイジクB	FEED GUIDE SHAFT, B	
16	014760632	1	アナクボミ595-28X6	SET SCREW SOCKET SM5.95-28X6	
17	S50214001	1	オクリアンナイジクA	FEED GUIDE SHAFT, A	
18	S59894001	2	アナボルト437-40X12	BOLT, SOCKET SM4.37-40X12	
19	S12004000	2	リニアブツシュ	LINEAR BUSH	
20	S02460001	2	トメワジクヨウC19	RETAINING RING, EXTERNAL C19	
21	S35184001	2	タマジクウケトメイタ	BALL BEARING STOPPER	
22	060660416	2	バインド318-40X4	SCREW BIND SM3.18-40X4	
23	S50215101	1	オクリセンサササエイタ	FEED SENSOR SUPPORT PLATE	
24	062680812	2	ナベコ437-40X8	SCREW PAN SM4.37-40X8	
25	025680132	2	ヒラザガネショウ4.37	WASHER PLAIN S SM4.37	
26	S50216101	1	オクリウデササエジク	SUPPORT SHAFT	
27	012500536	1	アナヒラ5X5	SET SCREW SOCKET (FT) M5X5	
28	S50217001	1	オクリウデ	FEED ARM	
29	S50218001	1	ニガシカムササエイタ	SUPPORT PLATE	
30	S50219101	1	ウワイトキリニガシカム	CAM	
31	S59893001	2	アナボルト437-40X10	BOLT, SOCKET SM4.37-40X10	
32	S59892001	2	アナボルト437-40X5	BOLT, SOCKET SM4.37-40X5	
33	110735002	4	ザガネ	WASHER	
34	S12004000	1	リニアブツシュ	LINEAR BUSH	
35	S59893001	2	アナボルト437-40X10	BOLT, SOCKET SM4.37-40X10	
36	028680242	2	バネザガネ2-4.37	WASHER SPRING 2-4.37	
37	S50221101	2	オクリオサエイタ	FEED PRESSER PLATE	
38	105130001	4	シメネジ3.57	SCREW, SM3.57	
39	S50222001	1	オクリウデササエ	FEED ARM SUPPORT	
40	S50223100	1	オクリカバー	COVER	
41	S59890001	1	アナボルト437-40X8	BOLT, SOCKET SM4.37-40X8	
42	025680132	1	ヒラザガネショウ4.37	WASHER PLAIN S SM4.37	
43	S50224001	1	オクリモータカバー	FEED MOTOR COVER	
44	062680812	2	ナベコ437-40X8	SCREW PAN SM4.37-40X8	
45	S50562101	1	ダンネジ6.35	SHOULDER SCREW SM6.35	
46	159080100	1	フィンガーガードM	FINGER GUARD, M	
47	159078001	1	ヌノツカミササエバネ	SPRING	
48	018502032	1	アナボルト5X20	BOLT SOCKET M5X20	
49	021500216	1	2シュナット5	NUT 2 M5	
			<-2用>	<For -2>	
50	S50220001	1	ナガサオクリイタ-2	LENGTH FEED PLATE, -2	
51	S37100302	1	ヌノツカミ25RSクミF	WORK CLAMP ASSY 25RS W/F-G	
52	159762002	1	ヌノツカミ25RS	WORK CLAMP 25RS	
53	159926001	1	ヌノツカミササエピン L	PIN, L	
54	107401001	2	ヌノツカミササエイタバネ	SPRING, PLATE	
55	107404001	2	シメネジ1.98	SCREW, SM1.98-64X2	
56	159927001	1	ヌノツカミササエピン S	PIN, S	

G. 送り関係 / Feed mechanism

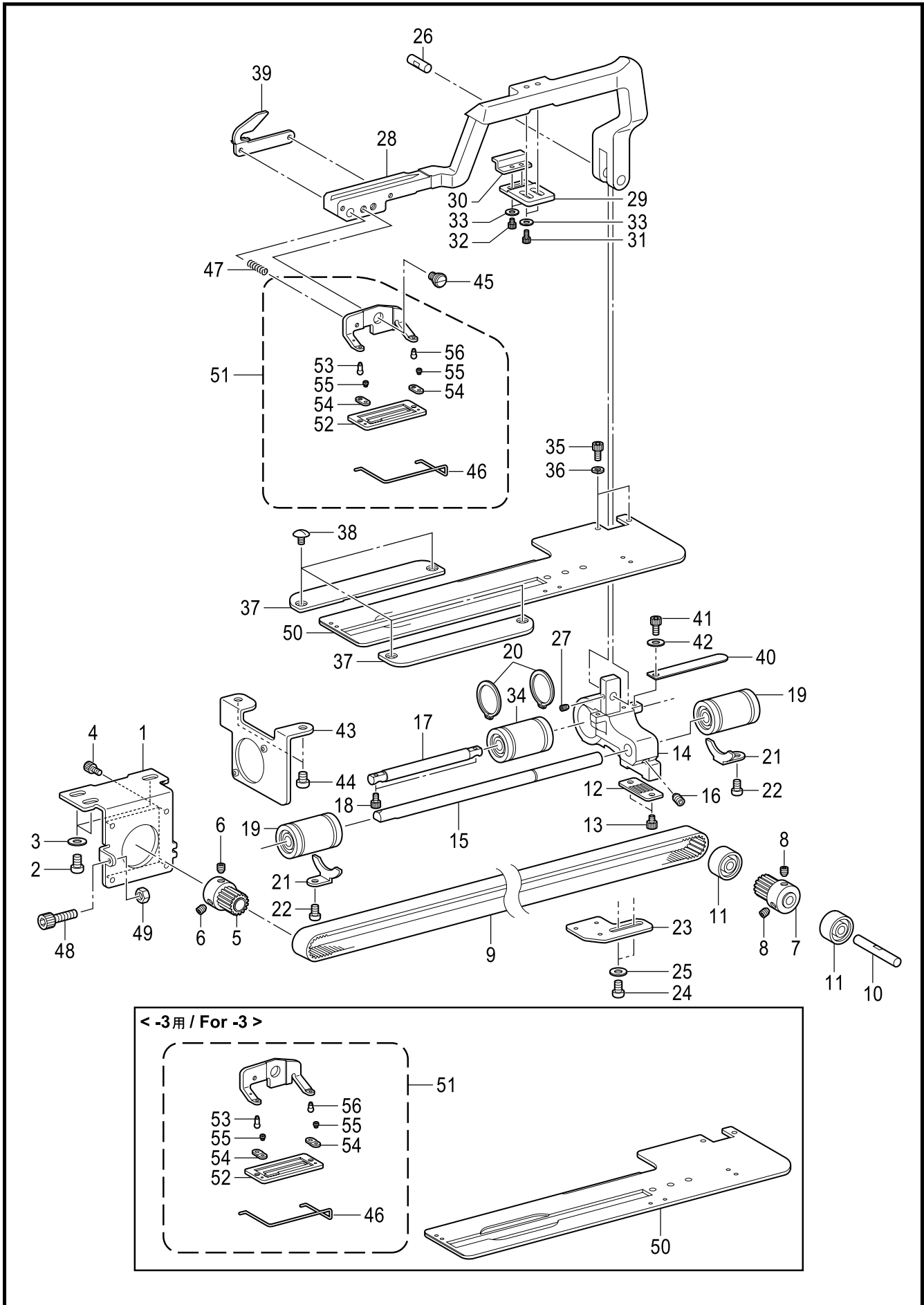

G. 送り関係 / Feed mechanism

REF.NO	CODE	Q'TY	品名	NAME OF PARTS	RM
			<-3用>	<For -3>	
50	S50225001	1	ナガサオクリイター-3	LENGTH FEED PLATE, -3	
51	S37102301	1	ニツトヨウヌノツカミ25クミF	WORK CLAMP ASSY 25-K W/F-G	
52	144630001	1	ニツトヨウヌノツカミ	WORK CLAMP 25-K	
53	159926001	1	ヌノツカミササエピン L	PIN, L	
54	144707001	2	ヌノツカミササエイタバネ	SPRING, PLATE	
55	107404001	2	シメネジ1.98	SCREW, SM1.98-64X2	
56	159927001	1	ヌノツカミササエピン S	PIN, S	

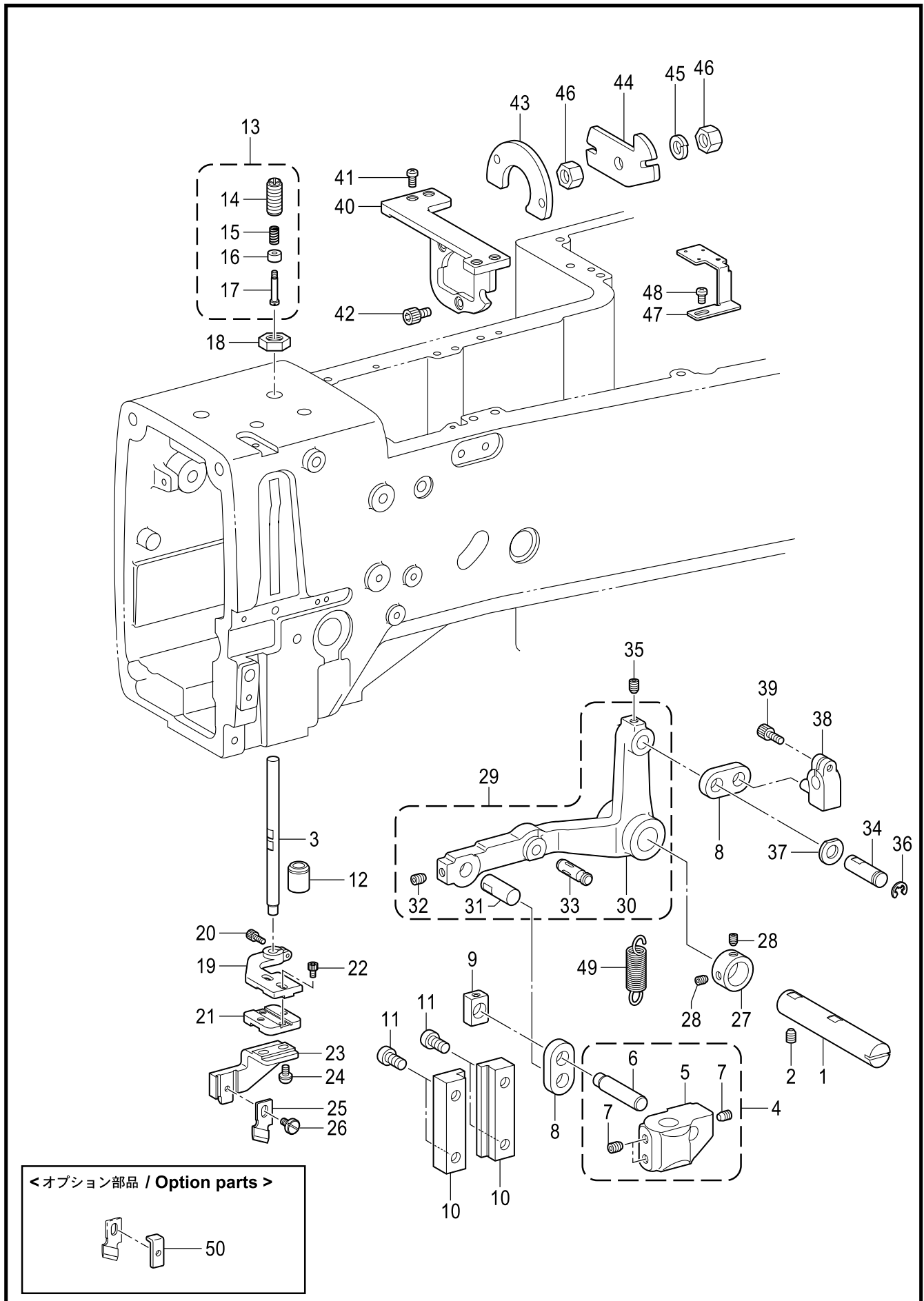

H. カッター関係 / Cutter mechanism

REF.NO	CODE	Q'TY	品名	NAME OF PARTS	RM
1	S50283001	1	カッタークドウウデジク	CUTTER DRIVING ARM SHAFT	
2	014760632	1	アナクボミ595-28X6	SET SCREW SOCKET SM5.95-28X6	
3	S50284101	1	カッターサドウジク	CUTTER DRIVING SHAFT	
4	S50285101	1	サドウジクホルダクミ	DRIVING SHAFT HOLDER ASSY	
5	S50286101	1	カッターサドウジクホルダ	CUTTER DRIVING SHAFT HOLDER	
6	S50287001	1	カッターサドウリンクジク	CUTTER DRIVING LINK SHAFT	
7	014780632	3	アナクボミ635-28X6	SET SCREW SOCKET SM6.35-28X6	
8	S50288001	2	カッタークドウリンク	CUTTER DRIVING LINK	
9	102630001	1	ハリボウアンナイカクコマ	NEEDLE BAR GUIDE SLIDE BLOCK	
10	SA2385001	2	カッターボウアンナイ	GUIDE, ; C-BAR	
11	062761012	4	ナベコ595-28X10	SCREW PAN SM5.95-28X10	
12	159117001	1	カッタサドウジクメタル	BUSH, ; C-DRIVING SHAFT	
13	S50289001	1	チヨウセツネジクミ	ADJUSTING SCREW ASSY	
14	S50290001	1	チヨウセツネジ	ADJUSTING SCREW	
15	S50291001	1	クツシヨンバネ	CUSHION SPRING	
16	S50292001	1	クツシヨンウケ	CUSHION SUPPORT	
17	S50293001	1	ダンネジ3.57	SHOULDER SCREW, SM3.57	
18	021910302	1	3シュナット1270-20	NUT 3 SM12.70-20	
19	S50294001	1	カッターホルダ	CUTTER HOLDER	
20	S59893001	1	アナボルト437-40X10	BOLT, SOCKET SM4.37-40X10	
21	S50295001	1	カッターホルダM	CUTTER HOLDER, M	
22	S59891001	2	アナボルト437-40X6	BOLT, SOCKET SM4.37-40X6	
23	S50296001	1	カッターホルダDL	CUTTER HOLDER, DL	
24	153057102	2	オクリイタシメネジ	SCREW, ROUND W/SOCKET SM4.37	
25	S51352001	1	カッタ1/2	CUTTER, 1/2	
26	115503001	1	シメネジ4.37	SCREW, SM4.37	
27	S09212001	1	セツカラー	SET SCREW COLLAR	
28	014770632	2	アナクボミ635-40X6	SET SCREW SOCKET SM6.35-40X6	
29	S50298101	1	カッタークドウウデクミ	CUTTER DRIVING ARM ASSY	
30	S50299101	1	カッタークドウウデ	CUTTER DRIVING ARM	
31	159104001	1	Cサドウウデピン	PIN	
32	014680632	1	アナクボミ437-40X6	SET SCREW SOCKET SM4.37-40X6	
33	159379001	1	ミゾツキピンBX6X18	PIN, DOWEL BX6X18	
34	S50300001	1	カッターリンクジク	CUTTER LINK SHAFT	
35	014760632	1	アナクボミ595-28X6	SET SCREW SOCKET SM5.95-28X6	
36	048060342	1	トメワE6	RETAINING RING E6	
37	110367001	1	ザガネ	WASHER, PLAIN SPECIAL 8	
38	SA2412001	1	カッターリンクダイ	CUTTER LINK BRACKET	
39	S59894001	1	アナボルト437-40X12	BOLT, SOCKET SM4.37-40X12	
40	S50362001	1	カッターソレノイドダイ	CUTTER SOLENOID BRACKET	
41	062711412	4	ナベコ476-32X14	SCREW PAN SM4.76-32X14	
42	018501032	3	アナボルト5X10	BOLT SOCKET M5X10	
43	S50363000	1	ストツパクツシヨン	STOPPER CUSHION	
44	S50364001	1	ソレノイドストツパ	SOLENOID STOPPER	
45	028080242	1	バネザガネ2-8	WASHER SPRING 2-8	
46	021080202	2	2シュナット8	NUT 2 M8	
47	S50365101	1	カッターセンサトリツケイタ	CUTTER SENSOR SETTING PLATE	
48	062710812	1	ナベコ476-32X8	SCREW PAN SM4.76-32X8	
49	S50366001	1	カッターモドシバネ	SPRING	
50	S50297001	1	<オプション部品> カッターオサエ	<OPTION PARTS> CUTTER HOLDER	

J. 糸切れ感知関係 / Thread breakage detector mechanism

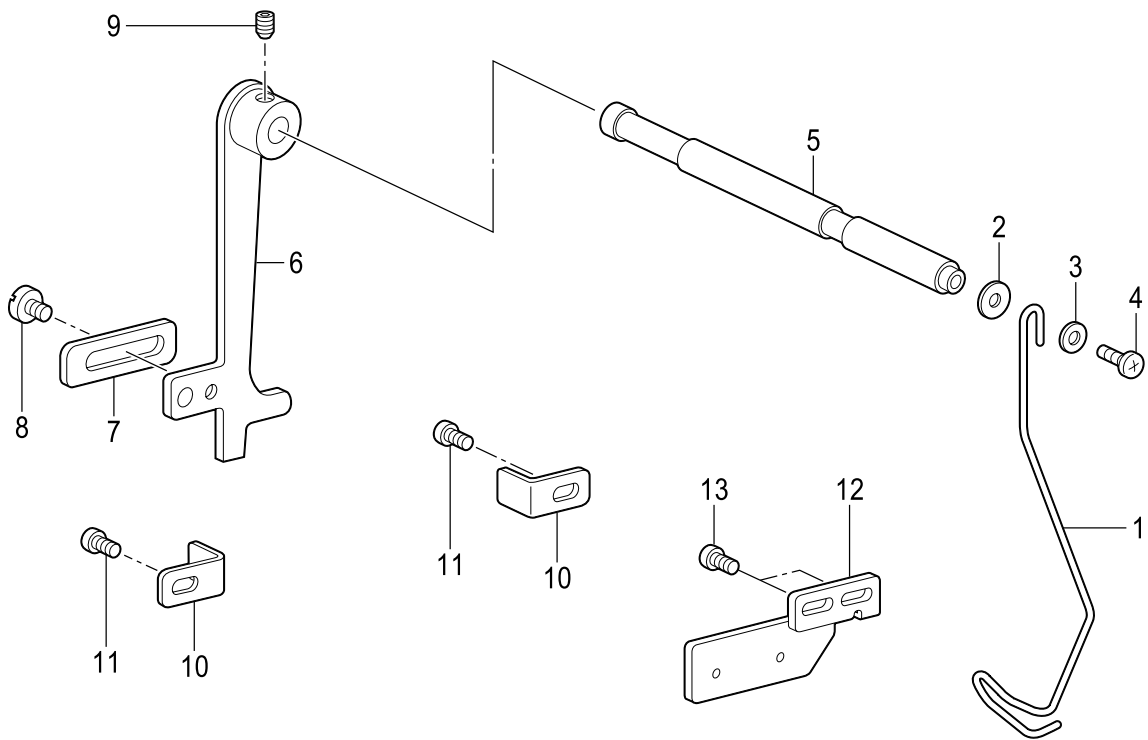

J. 糸切れ感知関係 / Thread breakage detector mechanism

REF.NO	CODE	Q'TY	品名	NAME OF PARTS	RM
1	S50273000	1	イトキレカンチイトアンナイ	THREAD GUIDE	
2	025060232	1	ヒラザガネチュウ6	WASHER PLAIN M 6	
3	025350332	1	ヒラザガネダイ3.5	WASHER PLAIN L 3.5	
4	060670612	1	バインド357-40X6	SCREW BIND SM3.57-40X6	
5	159145001	1	イトキレカンチレバ-ジク	TR-BREAKAGE PERCEIVING SHAFT	
6	141619001	1	カツタオチボウシイタ	FIXEING PLATE, ; C-BAR	
7	141620001	1	ボウシイタバランス	BALANCER	
8	101671002	1	シメネジ4.37	SCREW, SM4.37	
9	014760632	1	アナクボミ595-28X6	SET SCREW SOCKET SM5.95-28X6	
10	S50274001	2	レバ-ストツパ	LEVER STOPPER	
11	062400612	2	ナベコ4X6	SCREW PAN M4X6	
12	S50275001	1	イトキレカンチセンサイタ	THREAD BREAKAGE SENSOR PLATE	
13	062400612	2	ナベコ4X6	SCREW PAN M4X6	

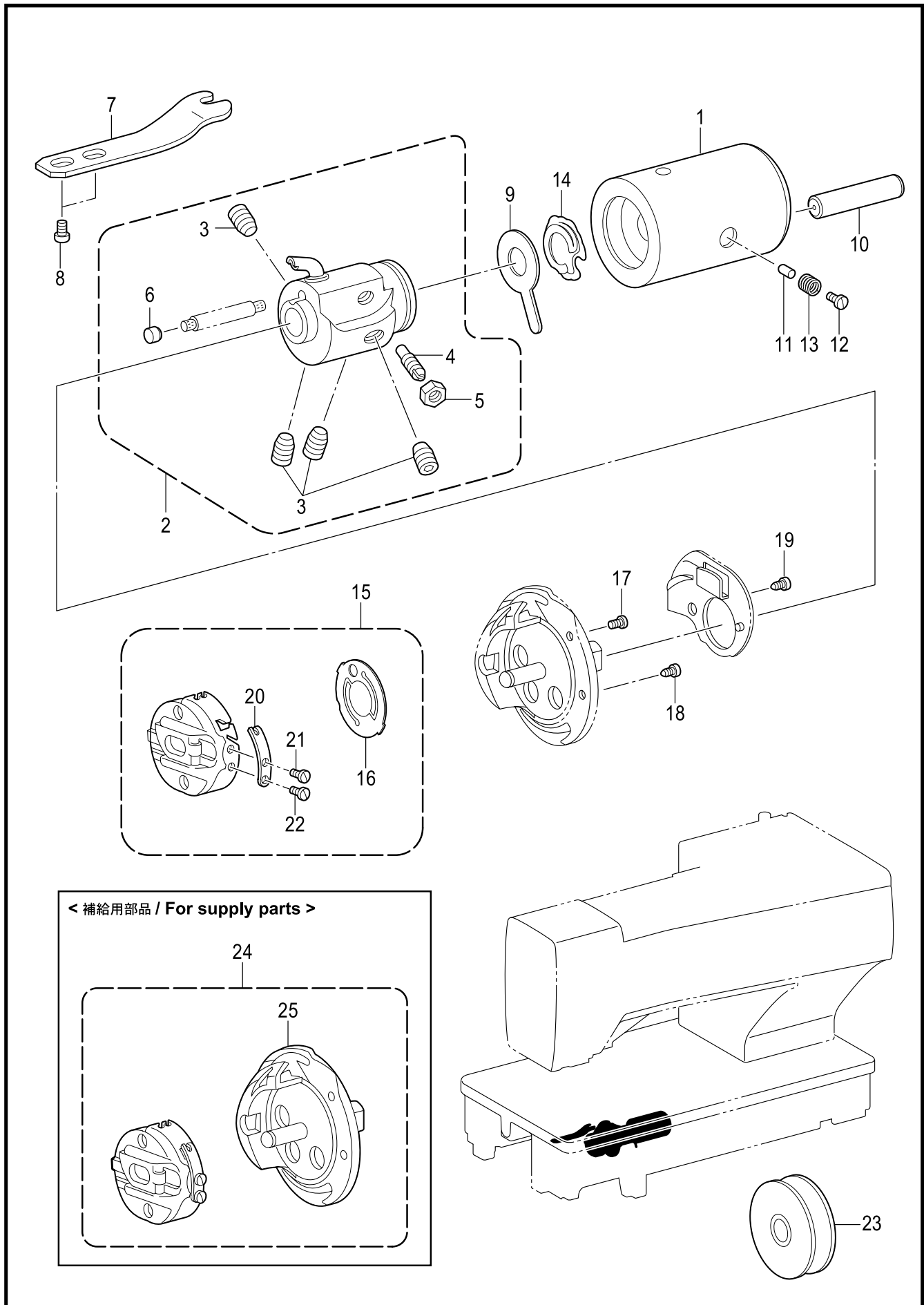



K. かま関係 / Rotary hook mechanism

REF.NO	CODE	Q'TY	品名	NAME OF PARTS	RM
1	S50226001	1	カマジクメタル	ROTARY HOOK SHAFT BUSH	
2	SA7405001	1	カマツギテソウクミ	ROTARY HOOK JOINT UNIT	
3	014760632	4	アナクボミ595-28X6	SET SCREW SOCKET SM5.95-28X6	
4	S56391001	1	トメネジ3.18	SET SCREW, SM3.18	
5	021660306	1	3シュナット318-40	NUT 3 SM3.18-40	
6	SA7402001	1	ゴムセン3.7	RUBBER CAP 3.7	
7	S50230001	1	カマトメ	B-CASE HOLDER POSITION BRACKET	
8	100644005	2	シメネジ4.37	SCREW, SM4.37	
9	S50232000	1	カマフエルト	ROTARY HOOK FELT	
10	S50231200	1	トウシンカラ	COLLAR	
11	S07478000	1	ゴムオサエ	RUBBER PRESSER	
12	S54741001	1	シメネジ6.35	SCREW, SM6.35	
13	S50233001	1	ゴムオサエバネ	SPRING	
14	S50111100	1	フエルトオサエバネ	SPRING	
15	SA9138001	1	ボビンケースクミ	BOBBIN CASE ASSY	
16	SA8126001	1	クウテンボウシバネ	ANTI-SPIN SPRING	
17	183526001	2	ナカカマオサエシメネジ	SCREW	
18	S50236001	1	ナカカマオサエシメネジB	SCREW	
19	183598001	1	ウライダシメネジ	SCREW	
20	S09477001	1	ボビンチヨウシバネ	SPRING	
21	180721001	1	チヨウシバネシメネジ	SCREW	
22	183507001	1	チヨウシネジ	ADJUSTING SCREW	
23	159158051	1	ボビン	BOBBIN	
			<補給用部品>	<For Supply parts>	
24	SA9140001	1	SA9139カマハコクミ	ROTARY HOOK ASSY W/BOX SA9139	
25	SA9141001	1	SA9137カマハコクミ	ROTARY HOOK ASSY W/BOX SA9137	

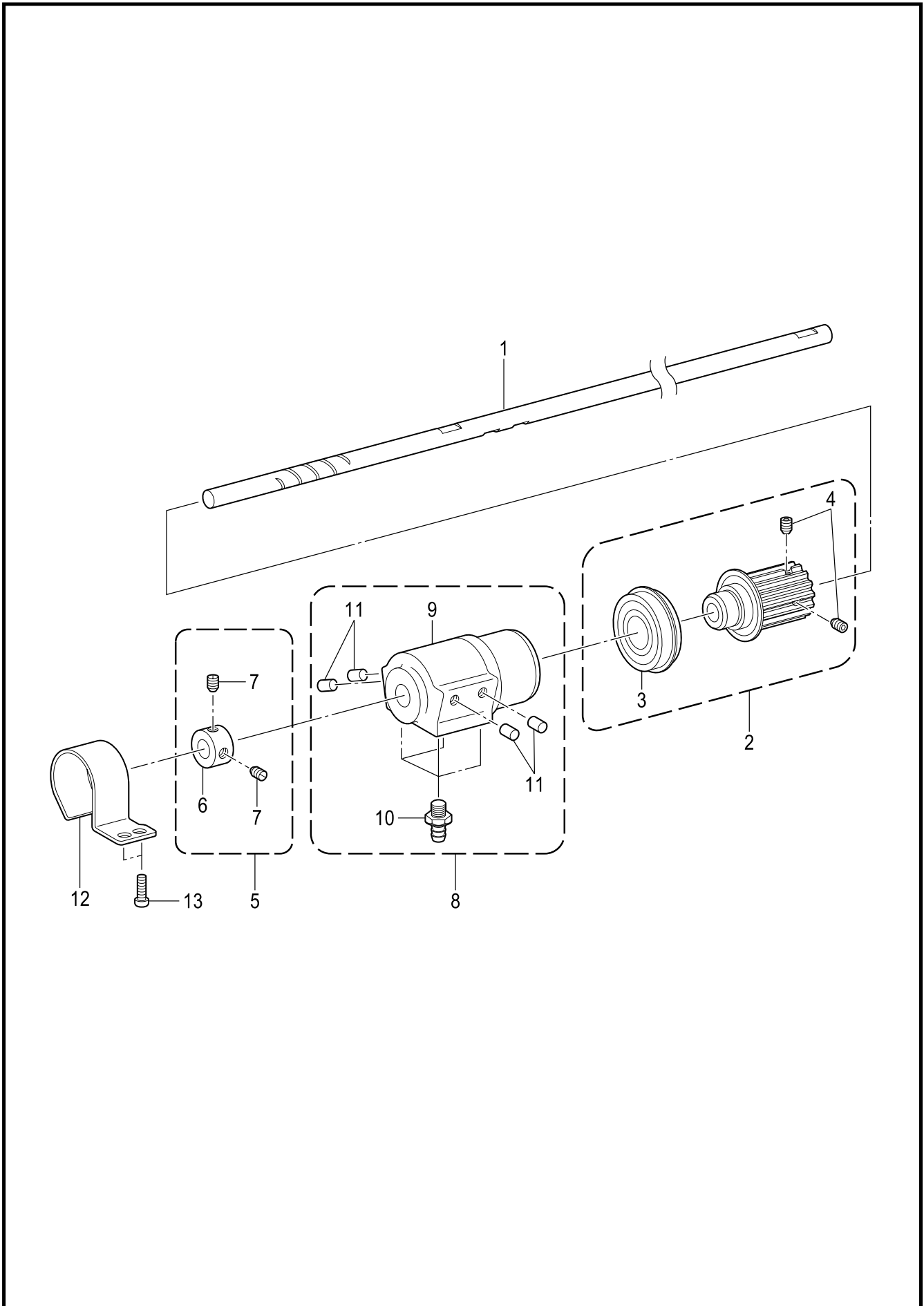

## L. 下軸関係 / Lower shaft mechanism

REF.NO	CODE	Q'TY	品名	NAME OF PARTS	RM
1	S50240001	1	シタジク	LOWER SHAFT	
2	SA3033001	1	タイミングプーリクミ	TIMMING PULLEY ASSY	
3	076002450	1	Rタマジクウケ6002DDNR	BALL BEARING RADIAL 6002DDNR	
4	014760632	2	アナクボミ595-28X6	SET SCREW SOCKET SM5.95-28X6	
5	183827001	1	セットカラークミ	SET SCREW COLLAR ASSY	
6	104521001	1	セットカラ-	SET SCREW COLLAR	
7	014770632	2	アナクボミ635-40X6	SET SCREW SOCKET SM6.35-40X6	
8	S50243101	1	シタジクメタルMクミ	BUSH ASSY M	
9	S50244101	1	シタジクメタルM	BUSH M	
10	S38735001	4	オイルクチ	OIL FEEDING PIPE	
11	142274101	4	ゴムセン4.2	RUBBER CAP, 4.2	
12	S50245001	1	シタジクメタルMカバー	COVER	
13	062670612	2	ナベコ357-40X6	SCREW PAN SM3.57-40X6	

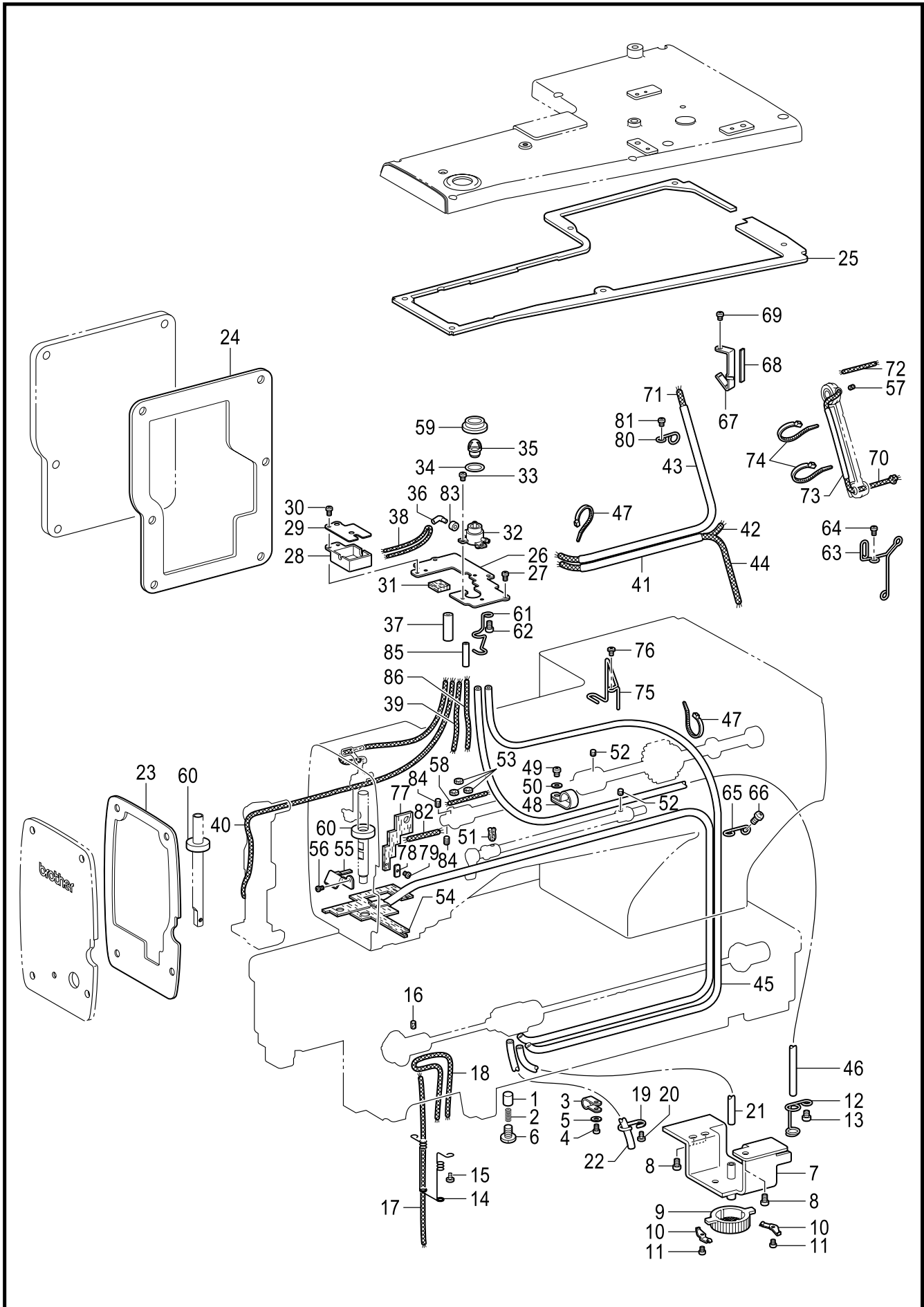

## M. 給油潤滑関係 / Lubrication

REF.NO	CODE	Q'TY	品名	NAME OF PARTS	RM
1	144875001	2	プランジヤ-	PLUNGER	
2	S52764001	2	プランジヤ-バネ	SPRING COMPRESSION	
3	552907000	2	コードホルダ#10	CORD HOLDER #10	
4	062670612	2	ナベコ357-40X6	SCREW PAN SM3.57-40X6	
5	025350132	2	ヒラザガネシヨウ3.5	WASHER PLAIN S 3.5	
6	112467002	2	シメネジ6.35	SCREW, SM6.35X5	
7	S50356001	1	オイルフィルタトリツケイタクミ	OIL FILTER BRACKET ASSY	
8	062680812	3	ナベコ437-40X8	SCREW PAN SM4.37-40X8	
9	144872101	1	ポンプフィルタ-	PUMP FILTER	
10	144874001	2	フィルタ-バネ	SPRING	
11	062670512	2	ナベコ357-40X5	SCREW PAN SM3.57-40X5	
12	S50359001	1	チューブササエD	TUBE SUPPORT, D	
13	062680612	1	ナベコ437-40X6	SCREW PAN SM4.37-40X6	
14	S50360001	1	カマフエルトササエ	ROTARY HOOK FELT SUPPORT	
15	060670612	2	バインド357-40X6	SCREW BIND SM3.57-40X6	
16	S50556000	1	フェルト	FELT	
17	S50563000	1	クミヒモ4X200	WICK, 4X200	
18	SA4063001	1	クミヒモ2X460	WICK, 2X460	
19	S50559001	1	チューブササエ	TUBE SUPPORT	
20	060670612	1	バインド357-40X6	SCREW BIND SM3.57-40X6	
21	S50557000	1	ビニルチューブ	OIL TUBE	
22	S50558000	1	ビニルチューブ	OIL TUBE, L=180	
23	S50513100	1	メンイタパツキン	FACE PLATE PACKING	
24	S50514000	1	ガワイタパツキン	REAR COVER PACKING	
25	S50515000	1	ウワフタパツキン	TOP COVER PACKING	
26	S50516001	1	トウシンベースササエ	WICK BASE SUPPORT	
27	062670612	2	ナベコ357-40X6	SCREW PAN SM3.57-40X6	
28	159187000	1	トウシンベースA	FELT BASE, A	
29	S50517001	1	トウシンベースフタ	CAP	
30	062680712	2	ナベコ437-40X7	SCREW PAN SM4.37-40X7	
31	S50518000	1	トウシンベースフェルト	FELT	
32	S50519000	1	オイルタ-ミナル	OIL TERMINAL	
33	062680612	2	ナベコ437-40X6	SCREW PAN SM4.37-40X6	
34	S50520000	1	パツキン	PACKING	
35	S50521000	1	オイルマド	OIL CAP	
36	159193000	1	オイルパイプB	OIL PIPE, B	
37	S50522000	1	ビニルチューブ	OIL TUBE	
38	S52763000	1	クミヒモ2X140	WICK, 2X140	
39	S50524000	1	クミヒモ3X160	WICK, 3X160	
40	S50525000	1	クミヒモ3X290	WICK, 3X290	
41	S50527000	1	ビニルチューブ	OIL TUBE	
42	S50528000	1	クミヒモ3X280	WICK, 3X280	
43	S50529000	1	ビニルチューブ	OIL TUBE, L=320	
44	S50530000	1	クミヒモ3X355	WICK, 3X355	
45	S50531000	1	ビニルチューブ	OIL TUBE	
46	S50532000	1	ビニルチューブ	OIL TUBE	
47	228475000	2	ケツソクバンド1.9X80	FASTENING BAND 1.9X80	
48	S00480000	1	コードホルダ#5	CORD HOLDER 5N	
49	062670612	1	ナベコ357-40X6	SCREW PAN SM3.57-40X6	
50	025350132	1	ヒラザガネシヨウ3.5	WASHER PLAIN S 3.5	
51	106436001	1	フェルト	FELT	
52	107149001	2	フェルト	FELT	
53	151927001	3	クラツチフェルト	FELT, ; CLUTCH	
54	S50533000	1	スイアゲチューブクミ	OIL TUBE ASSY	
55	S50536001	1	フェルトオサエ	FELT HOLDER	
56	062670512	1	ナベコ357-40X5	SCREW PAN SM3.57-40X5	
57	S25328001	1	フェルト	FELT	
58	S50537000	1	クミヒモ4X50	WICK, 4X50	
59	S50538001	1	アブラマドササエ	OIL WINDOW SUPPORT	
60	S50539000	2	アブラキリ	OIL REJECTOR	
61	S50540001	1	ハイユチューブササエ	TUBE SUPPORT	
62	062680612	1	ナベコ437-40X6	SCREW PAN SM4.37-40X6	
63	S50541001	1	チューブササエU	TUBE SUPPORT, U	

HE-800A-350

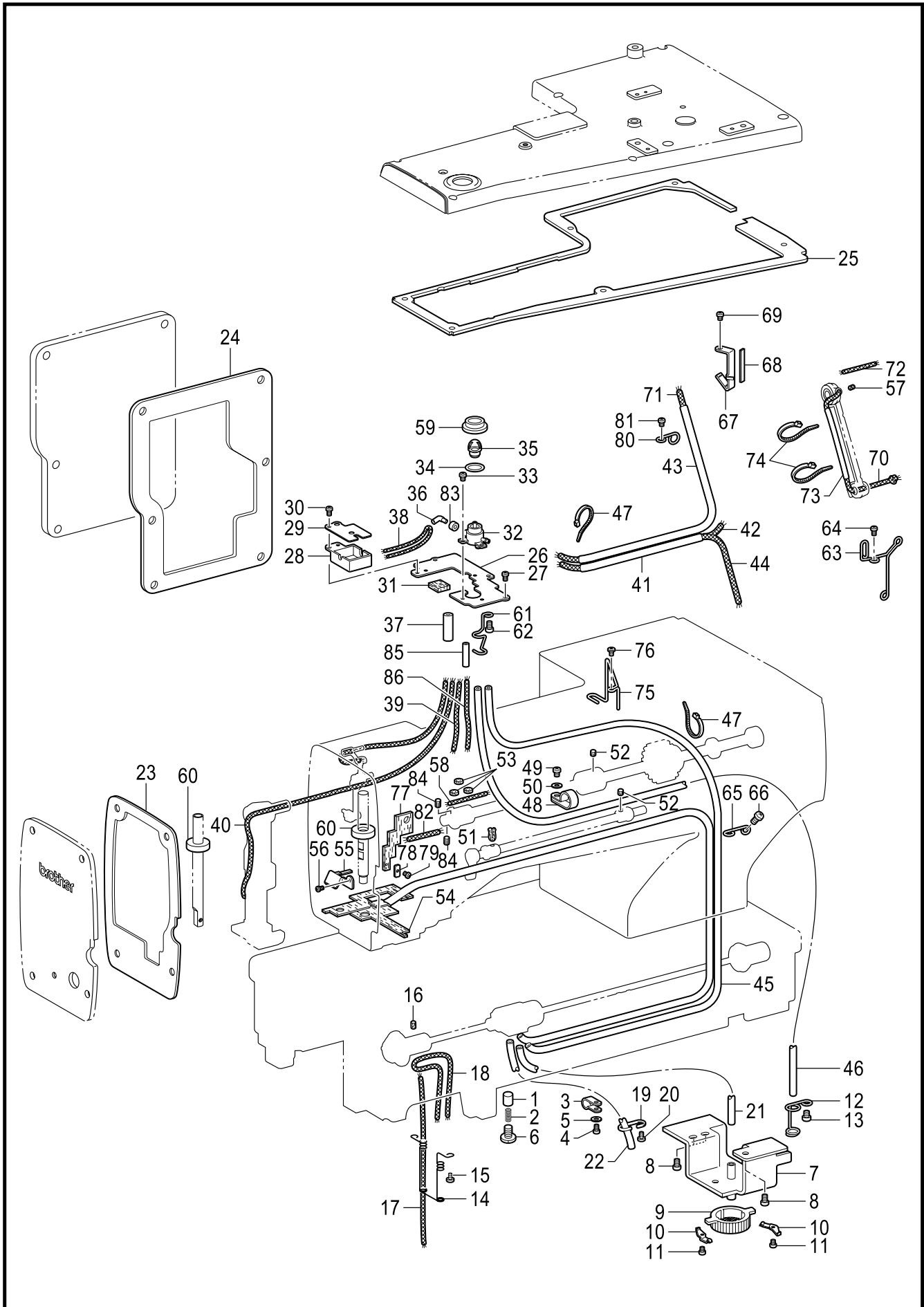

## M. 給油潤滑関係 / Lubrication

REF.NO	CODE	Q'TY	品名	NAME OF PARTS	RM
64	060670612	1	バインド357-40X6	SCREW BIND SM3.57-40X6	
65	S50542001	1	チューブササエM	TUBE SUPPORT, M	
66	062400612	1	ナベコ4X6	SCREW PAN M4X6	
67	S50543001	1	ハリフリフェルトササエ	FELT SUPPORT	
68	S50544000	1	フェルト	FELT	
69	062400612	1	ナベコ4X6	SCREW PAN M4X6	
70	S50545000	1	クミヒモ3X180	WICK, 3X180	
71	S50546000	1	クミヒモ3X370	WICK, 3X370	
72	S50537000	1	クミヒモ4X50	WICK, 4X50	
73	S50547000	1	ビニルチューブ	OIL TUBE	
74	228475000	2	ケツソクバンド1.9X80	FASTENING BAND 1.9X80	
75	S50548001	1	ハイユチューブササエR	TUBE SUPPORT, R	
76	060670612	1	バインド357-40X6	SCREW BIND SM3.57-40X6	
77	S50549000	1	クランクロッドフェルト	FELT	
78	S50550001	1	フェルトオサエイタ	FELT SUPPORT	
79	062670512	1	ナベコ357-40X5	SCREW PAN SM3.57-40X5	
80	S50551001	1	ハリフリチューブササエ	TUBE SUPPORT	
81	002300603	1	+ナベコ3X6	SCREW, PAN M3X6	
82	S50552000	1	クミヒモ4X70	WICK, 4X70	
83	S51020000	1	トウシンカラー	COLLAR	
84	S25328001	2	フェルト	FELT	
85	SA4066001	1	ビニルチューブ	OIL TUBE, L=40	
86	SA4067001	1	クミヒモ3X150	WICK, 3X150	

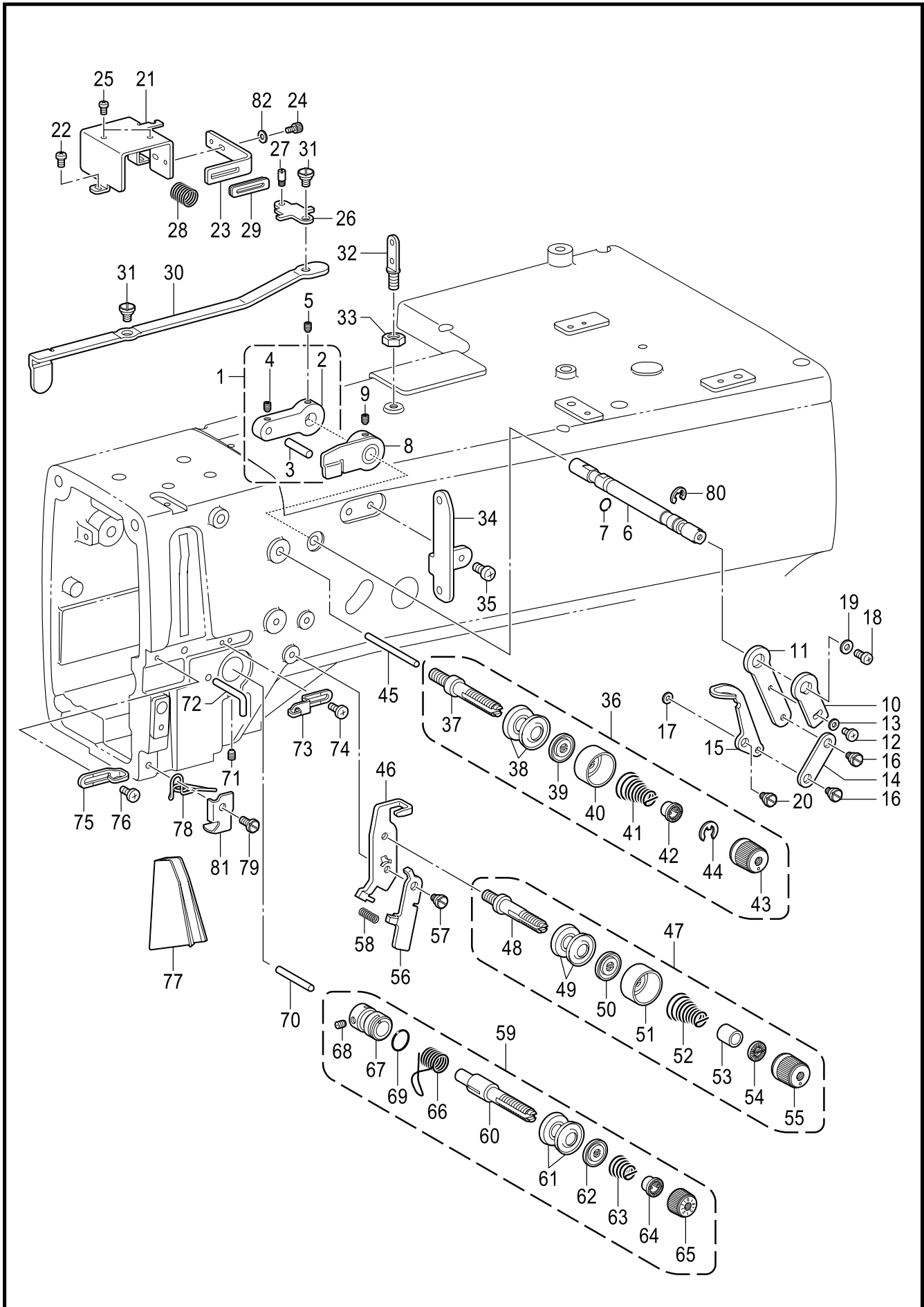



N. 糸通し関係 / Threading mechanism

REF.NO	CODE	Q'TY	品名	NAME OF PARTS	RM
1	S50368001	1	イトユルメクドウレバークミ	T-RELEASE DRIVING LEVER ASSY	
2	S50369001	1	イトユルメクドウレバー	TENSION RELEASE DRIVING LEVER	
3	S35095000	1	ニードルローラ4X13.8	NEEDLE ROLLER, 4X13.8	
4	014400432	1	アナクボミ4X4	SET SCREW SOCKET (CP) M4X4	
5	014760632	1	アナクボミ595-28X6	SET SCREW SOCKET SM5.95-28X6	
6	S50370001	1	イトユルメジク	TENSION RELEASE SHAFT	
7	081005070	1	OリングP5	O RING P5	
8	S50371101	1	イトユルメカム	TENSION RELEASE CAM	
9	014760632	1	アナクボミ595-28X6	SET SCREW SOCKET SM5.95-28X6	
10	S50372101	1	イトクリダシレバー	LEVER	
11	S50373101	1	イトトリチヨウセツレバー	ADJUSTING LEVER	
12	060670512	1	バインド357-40X5	SCREW BIND SM3.57-40X5	
13	100645003	1	ザガネ	WASHER	
14	S50374001	1	イトトリレバーリンク	LEVER LINK	
15	S50375001	1	イトトリレバー	TENSION TAKE-UP LEVER	
16	S50376101	2	ダンネジ4.37	SHOULDER SCREW SM4.37	
17	100645003	1	ザガネ	WASHER	
18	062680612	1	ナベコ437-40X6	SCREW PAN SM4.37-40X6	
19	025680234	1	ヒラザガネチュウ4.37	WASHER PLAIN M SM4.37	
20	SA6113001	1	ダンネジ4.37-5.5	SHOULDER SCREW SM4.37-5.5	
21	S50377001	1	イトユルメソレノイドホルダ	SOLENOID HOLDER	
22	062670612	2	ナベコ357-40X6	SCREW PAN SM3.57-40X6	
23	S50378001	1	プランジャオサエタ	PLATE	
24	018300636	1	アナボルト3X6	BOLT SOCKET M3X6	
25	062300502	2	ナベコ3X5	SCREW PAN M3X5	
26	SA0992001	1	イトユルメソレノイドリンク	TENSION RELEASE SOLENOID LINK	
27	S25456001	1	プランジャピン	PLUNGER PIN	
28	S50380000	1	プランジャモッドシバネ	SPRING	
29	SA0990001	1	イトユルメゴムクミ	TENSION RELEASE RUBBER ASSY	
30	S50382001	1	イトユルメリンク	TENSION RELEASE LINK	
31	S50376101	2	ダンネジ4.37	SHOULDER SCREW SM4.37	
32	141590001	1	イトトオシボウ	THREADING BAR, U	
33	150553003	1	ナツト5.95	NUT, SM5.95	
34	S50383001	1	イトカケ	THREAD RETAINER	
35	062670612	2	ナベコ357-40X6	SCREW PAN SM3.57-40X6	
36	S51184201	1	フクイトチヨウシクミ	SUB THREAD TENSION ASSY	
37	SA4232001	1	フクイトチヨウシボウ	SUB TENSION STUD	
38	145446001	2	イトチヨウシサラ	DISC, TENSION	
39	159805001	1	イトチヨウシサラオサエ	TENSION DISC PRESSER	
40	144103009	1	イトチヨウシサラオサエ	TENSION DISC PRESSER	
41	144110101	1	シタルーパイトチヨウシバネ	TENSION ADJUSTING SPRING	
42	S30564000	1	チヨウシバネウエザガネ	WASHER	
43	S30565003	1	イトチヨウシナツト	TENSION NUT	
44	SA4233001	1	ツマミストッパ	KNOB NUT STOPPER	
45	S50384101	1	イトユルメピン	TENSION RELEASE PIN	
46	S50385001	1	イトユルメレバーダイ	TENSION RELEASE LEVER BRACKET	
47	S51183101	1	イトチヨウシボウクミ	TENSION STUD ASSY	
48	145440001	1	イトチヨウシボウ	TENSION STUD	
49	145446001	2	イトチヨウシサラ	DISC, TENSION	
50	159805001	1	イトチヨウシサラオサエ	TENSION DISC PRESSER	
51	144103009	1	イトチヨウシサラオサエ	TENSION DISC PRESSER	
52	S50386101	1	イトチヨウシバネ	TENSION SPRING	
53	S50387001	1	チヨウシナツトカラ-	COLLAR	
54	151148001	1	MLマワリドメ	STOPPER ML	
55	S30565005	1	イトチヨウシナツト	TENSION NUT	
56	S50388001	1	イトユルメレバー	TENSION RELEASE LEVER	
57	114988001	1	ダンネジ4.37	SHOULDER SCREW, M4.37	
58	S50389001	1	イトユルメレバーバネ	SPRING	
59	S51182501	1	イトチヨウシボウダイクミ	TENSION STUD BRACKET ASSY	
60	S50391001	1	イトチヨウシボウL	TENSION STUD, L	
61	145446001	2	イトチヨウシサラ	DISC, TENSION	
62	159805001	1	イトチヨウシサラオサエ	TENSION DISC PRESSER	
63	159221101	1	イトチヨウシバネ	TENSION SPRING	

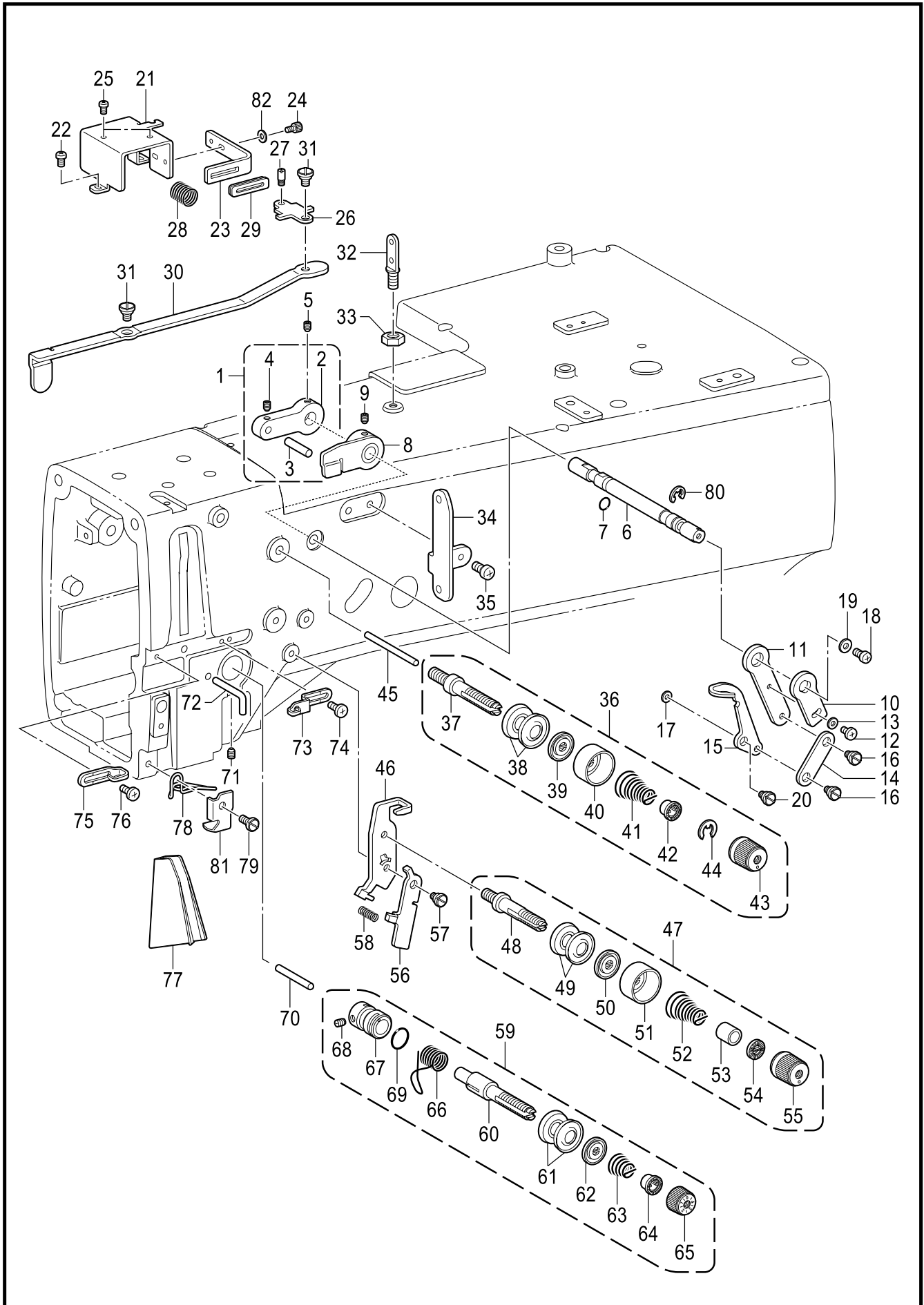

N. 糸通し関係 / Threading mechanism

REF.NO	CODE	Q'TY	品名	NAME OF PARTS	RM
64	S30564000	1	チヨウシバネウエザガネ	WASHER	
65	S31032001	1	イトチヨウシナツト	TENSION NUT	
66	SA9058001	1	イトトリバネ	THREAD TAKE-UP SPRING	
67	S50390101	1	イトチヨウシボウダイ	TENSION STUD BRACKET	
68	100402004	1	トメネジ3.57	SET SCREW, SM3.57	
69	081014870	1	リングS14	O RING S14	
70	S50384101	1	イトユルメピン	TENSION RELEASE PIN	
71	S55975001	1	アナトメネジ5.95	SET SCREW, SOCKET SM5.95	
72	159224001	1	ア-ムイトカケ	THREAD GUIDE, ARM	
73	S50392001	1	ア-ムイトアンナイ	ARM THREAD GUIDE	
74	060670512	1	バインド357-40X5	SCREW BIND SM3.57-40X5	
75	113316001	1	ア-ムイトアンナイ	ARM THREAD GUIDE	
76	060670512	1	バインド357-40X5	SCREW BIND SM3.57-40X5	
77	S50393000	1	イトトオシイタ	THREADING PLATE	
78	159917201	1	ア-ムイトアンナイシタ	THREAD GUIDE, L ;ARM	
79	112751003	1	シメネジ3.57	SCREW, SM3.57X7	
80	048060342	1	トメワE6	RETAINING RING E6	
81	SA3035001	1	イトアンナイオサエ	THREAD GUIDE COVER	
82	025030136	1	ヒラザガネシヨウ3	WASHER PLAIN S 3	

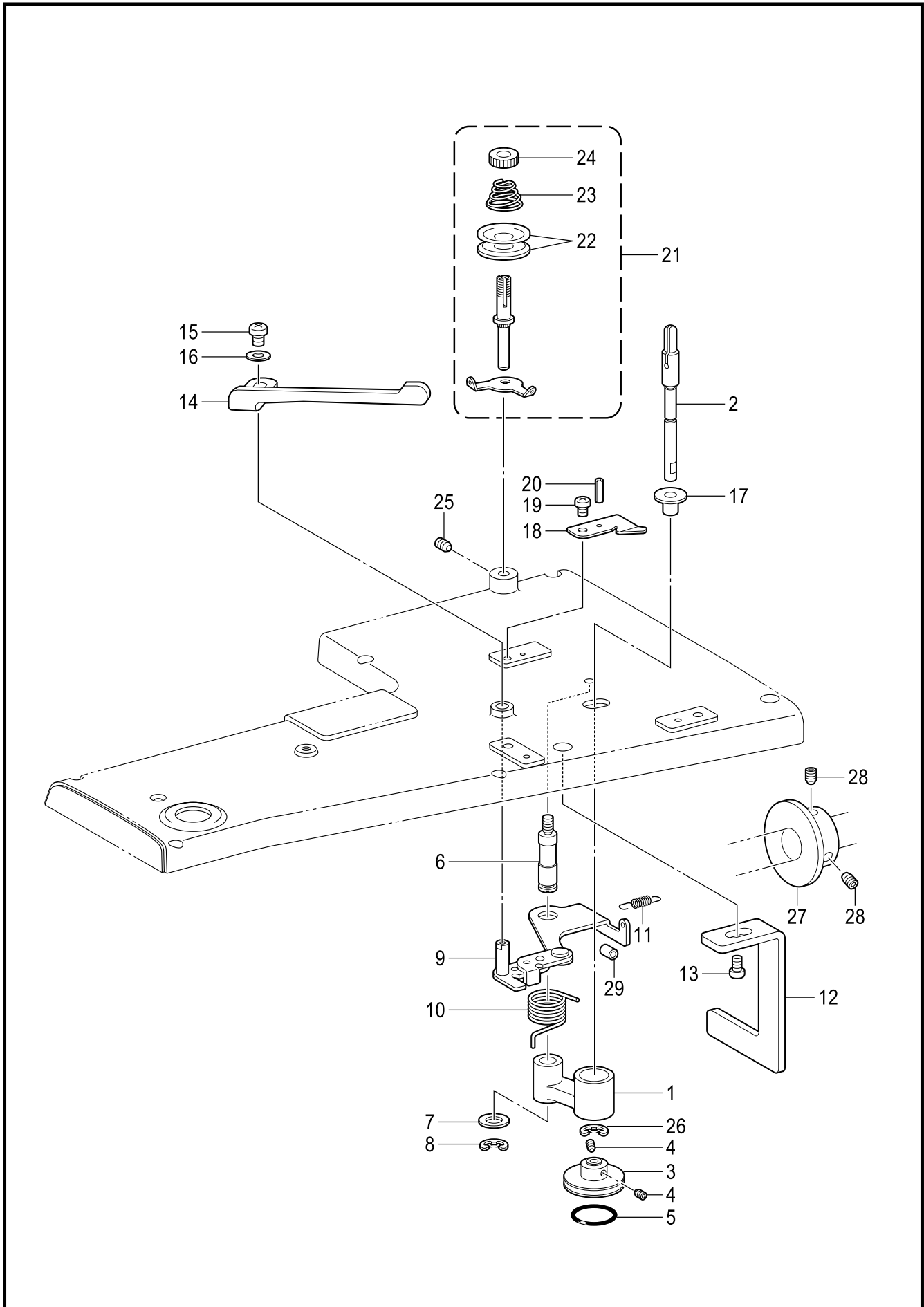

P. 糸巻関係 / Bobbin winder mechanism

REF.NO	CODE	Q'TY	品名	NAME OF PARTS	RM
1	S50276001	1	イトマキジクウケクミ	B-WINDER SHAFT BRACKET ASSY	
2	S50278001	1	イトマキジク	BOBBIN WINDER SHAFT	
3	S25410050	1	イトマキクルマ	BOBBIN WINDER WHEEL	
4	012400636	2	アナヒラ4X6	SET SCREW SOCKET (FT) M4X6	
5	S25789000	1	ゴムワ29	RUBBER RING, 29	
6	S50279101	1	イトマキウデジク	BOBBIN WINDER ARM SHAFT	
7	025080132	1	ヒラザガネシヨウ8	WASHER PLAIN S 8	
8	048060342	1	トメワE6	RETAINING RING E6	
9	S25413101	1	ボビンオサエジククミ	BOBBIN PRESSER SHAFT ASSY	
10	S25417001	1	イトマキバネ	SPRING	
11	S25418101	1	イトマキモドシバネ	SPRING	
12	S50280001	1	イトマキストツパ	BOBBIN WINDER STOPPER	
13	062400816	1	ナベコ4X8	SCREW PAN M4X8	
14	S25420051	1	ボビンオサエR	BOBBIN PRESSER, R	
15	062400816	1	ナベコ4X8	SCREW PAN M4X8	
16	026040236	1	ヒラザガネミガキ4	WASHER PLAIN M 4	
17	S10174000	1	ホコリヨケイタ	DUST GUARD PLATE	
18	157968001	1	メス	KNIFE	
19	062400616	1	ナベコ4X6	SCREW PAN M4X6	
20	047200642	1	スプリングピンAW2	PIN SPRING ROLL AW2	
21	S38736301	1	イトマキイトチヨウシクミ	BOBBIN WINDER TENSION ASSY	
22	145446002	2	イトチヨウシサラ	DISC, TENSION	
23	115188101	1	シュイトチヨウシバネ	TENSION SPRING	
24	108265009	1	イトチヨウシナツト	TENSION NUT	
25	012400636	1	アナヒラ4X6	SET SCREW SOCKET (FT) M4X6	
26	048040342	1	トメワE4	RETAINING RING E4	
27	S50281000	1	イトマキプーリ	BOBBIN WINDER PULLEY	
28	014780632	2	アナクボミ635-28X6	SET SCREW SOCKET SM6.35-28X6	
29	S50282000	1	イトマキレバークツシヨウ	B-WINDER LEVER CUSHION	

Q . 上糸切り関係 / Upper thread trimmer mechanism

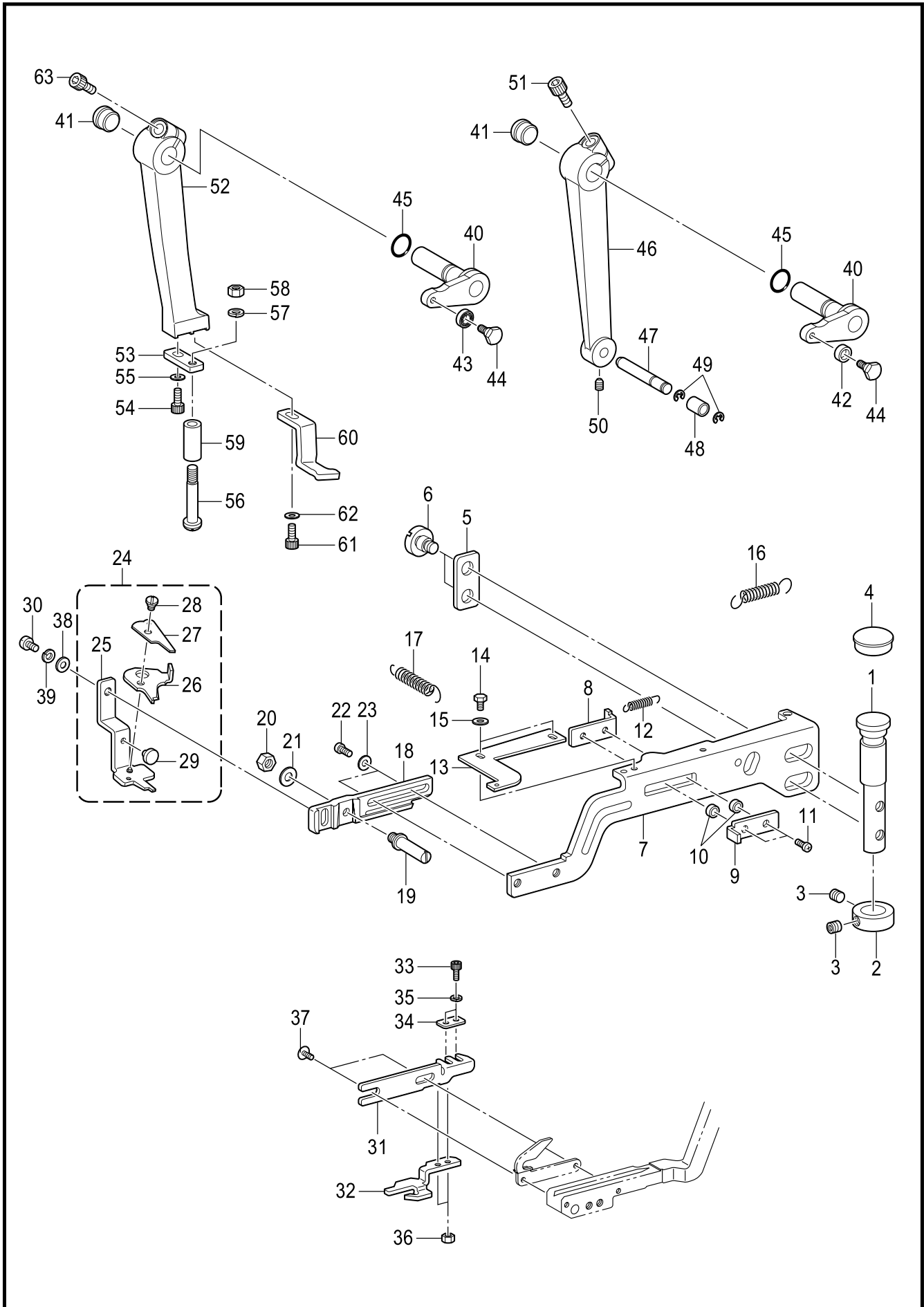

HE-800A-409

Q. 上糸切り関係 / Upper thread trimmer mechanism

REF.NO	CODE	Q'TY	品名	NAME OF PARTS	RM
1	S50394001	1	ウワイトキリシテンジク	UPPER T-TRIMMER FULCRUM SHAFT	
2	110027001	1	セツカラー	SET SCREW COLLAR	
3	014760632	2	アナクボミ595-28X6	SET SCREW SOCKET SM5.95-28X6	
4	S23337001	1	ゴムセン18.5	RUBBER CAP, 18.5	
5	S52761101	1	ウワイトキリレバーザガネ	WASHER RECTANGLE 15X32X2.4	
6	S19817001	2	ダンネジ5.95	SHOULDER SCREW, SM5.95	
7	S50395201	1	ウワイトキリレバークミ	U-THREAD TRIMMER LEVER ASSY	
8	S50398001	1	ハサミモドリトメイタ	STOP PLATE	
9	S50399101	1	ハサミモドシイタ	BACK PLATE	
10	S50400001	2	モドシイタカラ	COLLAR	
11	062670712	2	ナベコ357-40X7	SCREW PAN SM3.57-40X7	
12	S50401001	1	ウワイトキリモドシバネ	SPRING	
13	SA9165001	1	チヨウセイイタ	ADJUSTING PLATE	
14	144075001	2	ボルト3.57	BOLT, SM3.57	
15	105161003	2	ザガネ	WASHER, PLAIN	
16	S02563001	1	モドシバネ	SPRING, EXTENSION	
17	S02563001	1	モドシバネ	SPRING, EXTENSION	
18	S50403101	1	ハサミトリツケイタ	SETTING PLATE	
19	159343001	1	ハサミササエジク	SUPPORT STUD	
20	021680202	1	2シュナット437-40	NUT 2 SM4.37-40	
21	025680132	1	ヒラザガネショウ4.37	WASHER PLAIN S SM4.37	
22	062680612	2	ナベコ437-40X6	SCREW PAN SM4.37-40X6	
23	025680232	2	ヒラザガネチュウ4.37	WASHER PLAIN M SM4.37	
24	S50404401	1	ハサミクミ	UPPER THREAD TRIMMER ASSY	
25	S50405301	1	ハサミDクミ	THREAD TRIMMER ASSY D	
26	S50113101	1	ハサミM	UPPER THREAD TRIMMER, M	
27	141513001	1	ハサミU	UPPER THREAD TRIMMER UPPER	
28	141514001	1	ハサミダンネジ	SHOULDER SCREW, SM3.18	
29	S52431000	1	ハサミストツパ	U-THREAD TRIMMER STOPPER	
30	100644005	1	シメネジ4.37	SCREW, SM4.37	
31	SA9166001	1	ヒラキカムトリツケイタ	OPENING CAM SETTING PLATE	
32	SA9167001	1	ハサミヒラキカム	OPENING CAM	
33	018300836	2	アナボルト3X8	BOLT SOCKET M3X8	
34	SA9168001	1	ヒラキカムザガネ	WASHER PLAIN	
35	028030246	2	バネザガネ2-3	WASHER SPRING 2-3	
36	021300206	2	2シュナット3	NUT 2 M3	
37	107093002	2	シメネジ4.37	SCREW, SM4.37	
38	025680232	1	ヒラザガネチュウ4.37	WASHER PLAIN M SM4.37	
39	028680242	1	バネザガネ2-4.37	WASHER SPRING 2-4.37	
40	S50410101	2	イトキリクドウレバー	THREAD TRIMMER DRIVING LEVER	
41	117936001	2	ゴムセン9.4	RUBBER CAP, 9.4	
42	S50411101	1	クドウレバーコロ	DRIVING LEVER ROLLER	
43	S50412000	1	タマジクウケ106ZZS	BALL BEARING, 106ZZS	
44	S50413101	2	クドウレバーダンネジ	SHOULDER SCREW	
45	081012070	2	リングP12	O RING P12	
46	S50414001	1	ゼンゴサドウウデ	LONGITUDINAL FEED ARM	
47	S50415001	1	ゼンゴウデピン	L-FEED ARM PIN	
48	S50416001	1	ゼンゴウデコロ	L-FEED ARM ROLLER	
49	048040342	2	トメフE4	RETAINING RING E4	
50	014680632	1	アナクボミ437-40X6	SET SCREW SOCKET SM4.37-40X6	
51	018061632	1	アナボルト6X16	BOLT SOCKET M6X16	
52	SA9169001	1	イトキリサドウウデ	THREAD TRIMMER DRIVING ARM	
53	SA9170001	1	ウデコロササエイタ	SUPPORT PLATE	
54	S59893001	1	アナボルト437-40X10	BOLT, SOCKET SM4.37-40X10	
55	025680132	1	ヒラザガネショウ4.37	WASHER PLAIN S SM4.37	
56	SA9172001	1	ウデコロダンネジ	ROLLER SHOULDER SCREW	
57	028050243	1	バネザガネ2-5	WASHER, SPRING 2-5	
58	021500316	1	3シュナット5	NUT 3 M5	
59	S50511101	1	サドウウデコロ	DIFFERENTIAL ARM ROLLER	
60	SA9171001	1	ハサミモドシストツパ	STOPPER	
61	S59893001	1	アナボルト437-40X10	BOLT, SOCKET SM4.37-40X10	
62	025680132	1	ヒラザガネショウ4.37	WASHER PLAIN S SM4.37	
63	018061632	1	アナボルト6X16	BOLT SOCKET M6X16	

R. 下糸切り関係 / Lower thread trimmer mechanism

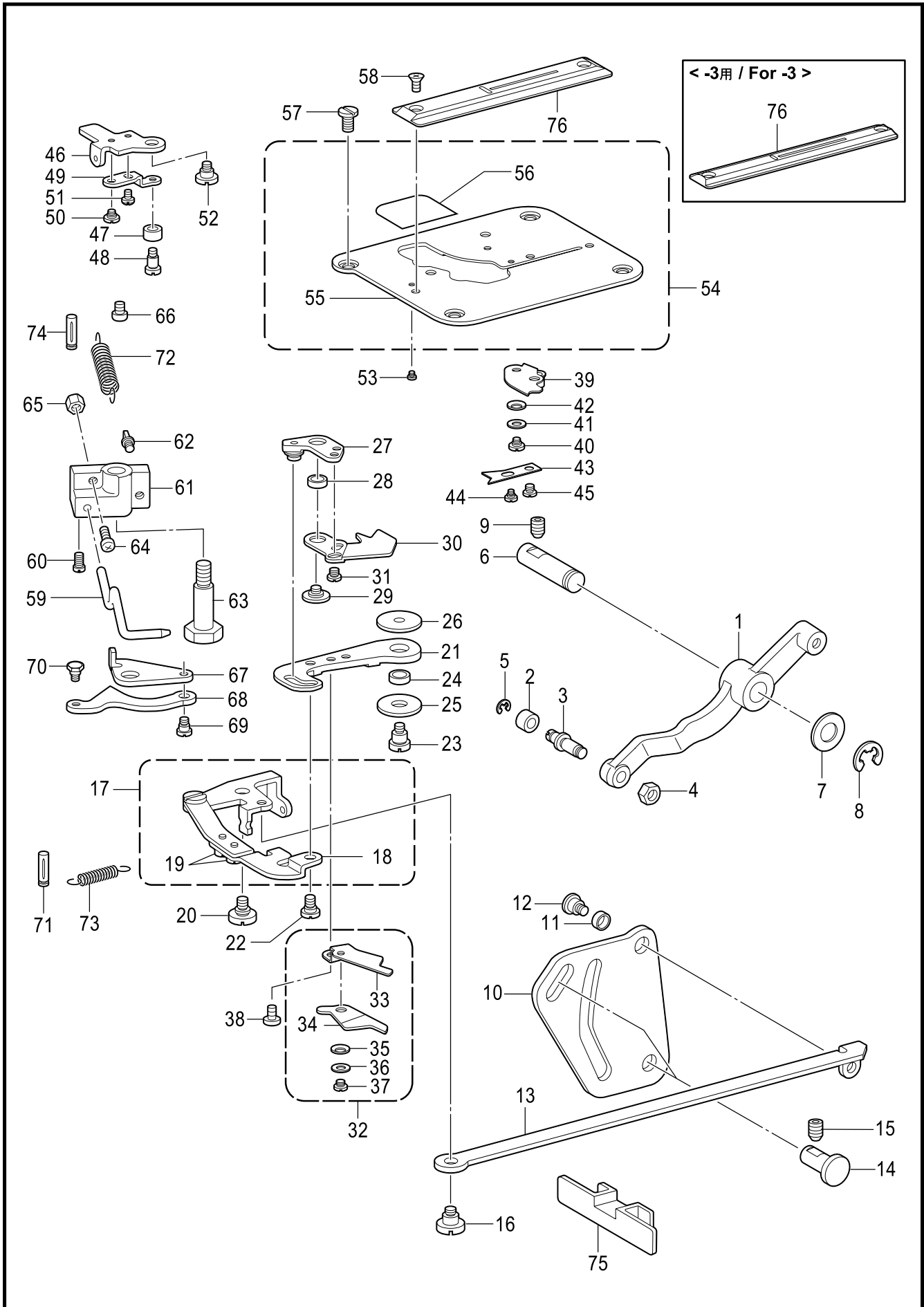

HE-800A-410



## R. 下糸切り関係 / Lower thread trimmer mechanism

REF.NO	CODE	Q'TY	品名	NAME OF PARTS	RM
1	S50246001	1	シタイトキリカムレバー	LOWER THREAD TRIMMER CAM LEVER	
2	107744001	1	コロ	ROLLER	
3	141519001	1	イトキリサドウカムコロジク	ROLLER SHAFT	
4	110161004	1	ナツト4.76	NUT, SM4.76	
5	048030342	1	トメワE3	RETAINING RING E3	
6	159267001	1	シタイトキリカムジク	CAM SHAFT, ; L-TR	
7	110494001	1	ザガネ	WASHER, PLAIN 9.5	
8	048080342	1	トメワE8	RETAINING RING E8	
9	014760632	1	アナクボミ595-28X6	SET SCREW SOCKET SM5.95-28X6	
10	S50247101	1	シタイトキリカム	LOWER THREAD TRIMMER CAM	
11	S50411101	1	クドウレバーコロ	DRIVING LEVER ROLLER	
12	145478101	1	ダンネジ4.76	SHOULDER SCREW, SOCKET SM4.76	
13	S50248101	1	シタイトキリカムレンカン	L-THREAD TRI.CAM CONNECTIN ROD	
14	150491101	2	レバージク	LEVER SHAFT	
15	014760632	2	アナクボミ595-28X6	SET SCREW SOCKET SM5.95-28X6	
16	159269001	1	シタイトキリリンクダンネジ	SHOULDER SCREW, SM4.37	
17	S50249201	1	シタイトキリリンククミ	LOWER THREAD TRIMMER LINK ASSY	
18	S59987101	1	シタイトキリレンカンA	LOWER THREAD CONNECTING ROD A	
19	062680512	2	ナベコ437-40X5	SCREW PAN SM4.37-40X5	
20	149127001	1	ダンネジ6.35	SHOULDER SCREW, SM6.35	
21	S50252001	1	メスサドウレバー	KNIFE DRIVING LEVER	
22	113730001	1	ダンネジ4.37	SHOULDER SCREW, SM4.37	
23	159272001	1	メスサドウレバダンネジ	SHOULDER SCREW	
24	S00903001	1	メスサドウレバーカラー	COLLAR	
25	S00901001	1	メスサドウレバザガネU	WASHER, PLAIN L 6.4: U	
26	SA3001001	1	メスサドウレバザガネD	WASHER, PLAIN L 4.8: D	
27	S50253001	1	サバキクドウレバークミ	LEVER ASSY	
28	S50257001	1	サバキクドウレバーカラー	COLLAR	
29	S00712101	1	シメネジ4.37	SCREW, SM4.37	
30	S50258201	1	シタイトサバキ	LOWER THREAD RETAINER	
31	110215002	2	シメネジ3.57	SCREW SM3.57	
32	S50259101	1	シタコテイハソウクミ	LOWER FIXED KNIFE UNIT	
33	S50260101	1	シタコテイハクミ	LOWER FIXED KNIFE ASSY	
34	S50263001	1	シタイトウハ	MOVABLE KNIFE	
35	S50264000	1	マゲワツシヤ-4302	WASHER	
36	025040132	1	ヒラザガネシヨウ4	WASHER PLAIN S 4	
37	060630312	1	バインド238-56X3	SCREW BIND SM2.38-56X3	
38	060670412	2	バインド357-40X4	SCREW BIND SM3.57-40X4	
39	S50265001	1	シタイトツカミイタクミ	LOWER THREAD CLAMP PLATE ASSY	
40	141514001	1	ハサミダンネジ	SHOULDER SCREW, SM3.18	
41	025040132	1	ヒラザガネシヨウ4	WASHER PLAIN S 4	
42	S50269000	1	マゲワツシヤ-5011	WASHER	
43	S50270000	1	シタイトオサエ	LOWER THREAD PRESSER	
44	145371001	1	ダンネジ2.38	SHOULDER SCREW, SM2.38	
45	110215002	1	シメネジ3.57	SCREW SM3.57	
46	S52433001	1	シタイトツカミヒラキイタA	OPENING PLATE A	
47	110167001	1	コロ	ROLLER	
48	110168001	1	コロジク	ROLLER SHAFT	
49	S52434001	1	シタイトツカミヒラキイタB	OPENING PLATE, B	
50	141514001	1	ハサミダンネジ	SHOULDER SCREW, SM3.18	
51	123185001	1	マルヒラネジ3.57X4.5	SCREW, ROUND SM3.57X4.5	
52	149127001	1	ダンネジ6.35	SHOULDER SCREW, SM6.35	
53	105970001	1	シメネジ2.38	SCREW, SM2.38	
54	S52778101	1	ハリイタベースクミ	BASE PLATE ASSY	
55	S50303101	1	ハリイタベース	BASE PLATE	
56	S52770000	1	ハリイタカバー	NEEDLE PLATE COVER	
57	106629002	4	シメネジ4.37	SCREW, SM4.37	
58	S01696001	2	サラネジ3.57X6	SCREW, FLAT SM3.57X6	
59	S50323000	1	ボビンオサエ	BOBBIN PRESSER	
60	S01998001	1	アタマツキトメネジ3.57	SET SCREW, SM3.57-40X6	
61	S50324001	1	ボビンオサエダイ	BOBBIN PRESSER BRACKET	
62	107639001	1	バネカケU	SPRING HOOK, U	
63	159924001	1	ストツブレバーダンネジ	SHOULDER SCREW	

R . 下糸切り関係 / Lower thread trimmer mechanism

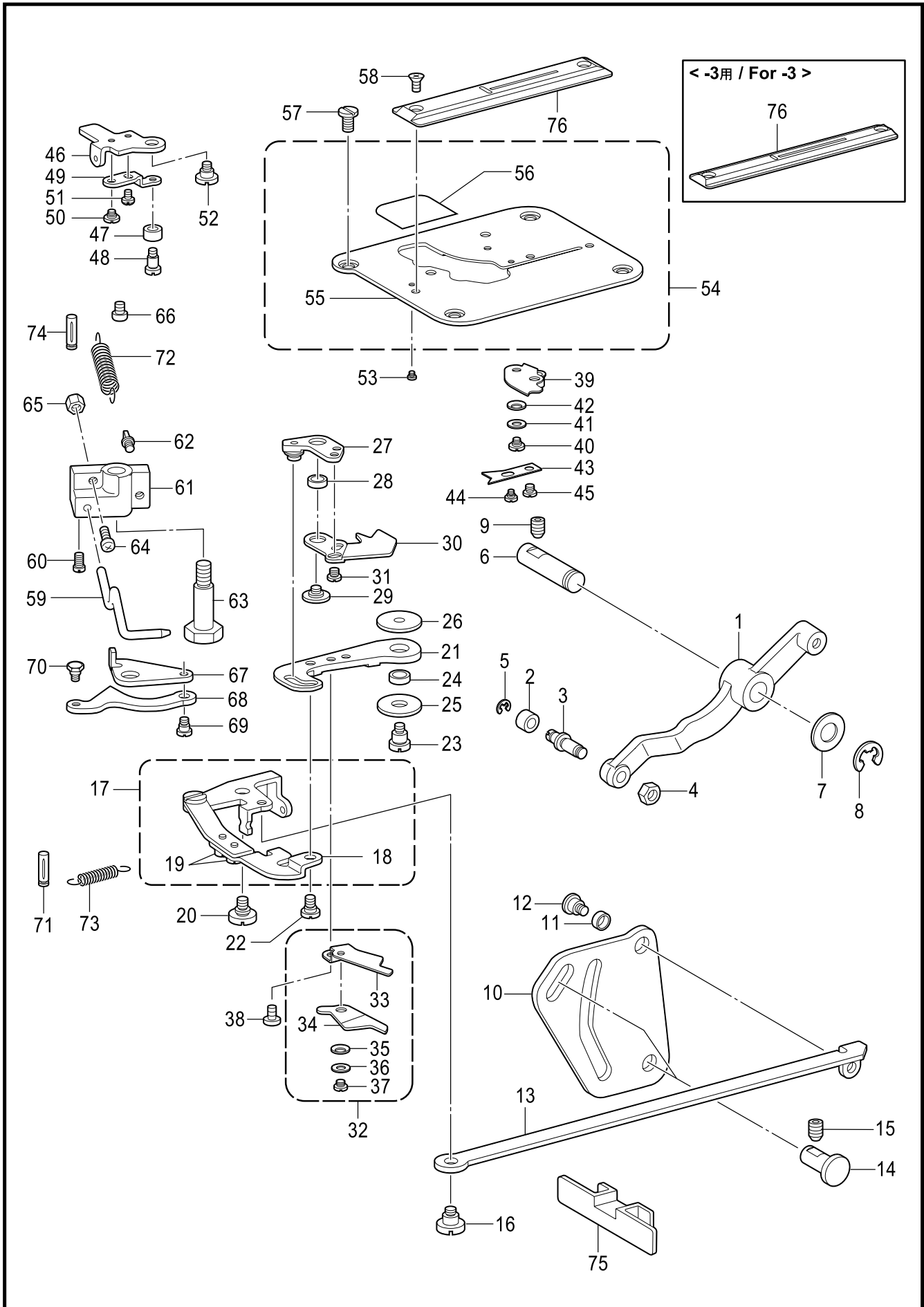

HE-800A-410

## R. 下糸切り関係 / Lower thread trimmer mechanism

REF.NO	CODE	Q'TY	品名	NAME OF PARTS	RM
64	062671612	1	ナベコ357-40X16	SCREW PAN SM3.57-40X16	
65	021670202	1	2シュナット357-40	NUT 2 SM3.57-40	
66	062680512	2	ナベコ437-40X5	SCREW PAN SM4.37-40X5	
67	S50325001	1	カバーヒラキホジヨイタ	AUXILIARY PLATE	
68	S50326001	1	ポビンオサエヒラキイタ	OPENING PLATE	
69	159113101	1	ダンネジ3.18	SHOULDER SCREW SM3.18	
70	105237002	1	ダンネジ3.57	SHOULDER SCREW SM3.57	
71	159379001	1	ミゾツキピンBX6X18	PIN, DOWEL BX6X18	
72	S50327001	2	ポビンオサエヒキバネ	EXTENSION SPRING	
73	S50328001	1	シタイトツカミヒラキイタバネ	PLATE SPRING	
74	159379001	1	ミゾツキピンBX6X18	PIN, DOWEL BX6X18	
75	S50329000	1	シタイトキリレンカンカバー	COVER	
			<-2用>	<For -2>	
76	S50664001	1	ハリイタ1.4S	NEEDLE PLATE, 1.4S	
			<-3用>	<For -3>	
76	S51248101	1	ハリイタ1.2S-3	NEEDLE PLATE, 1.2S-3	

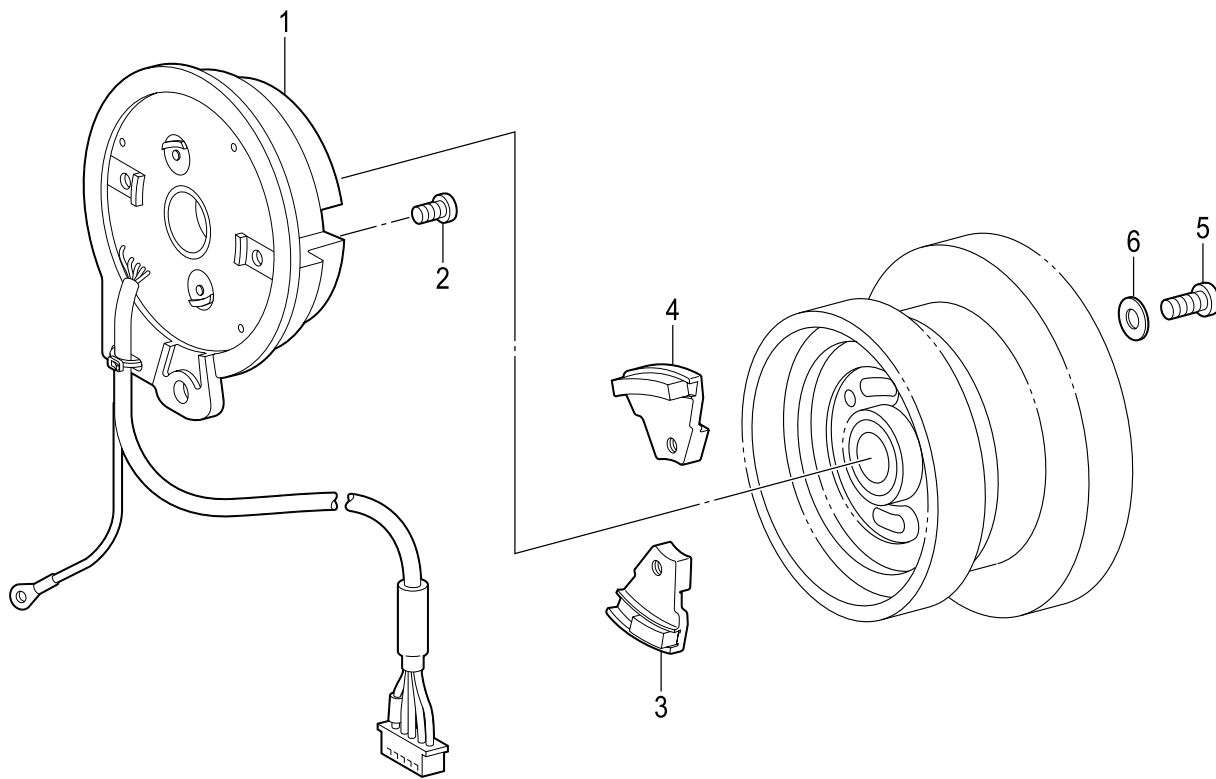

## S. 針位置検出器関係 / Synchronizer

REF.NO	CODE	Q'TY	品名	NAME OF PARTS	RM
1	S50657001	1	シンクロナイザクミH80	SYNCHRONIZER ASSY H80	
2	062400806	2	ナベコ4X8	SCREW PAN M4X8	
3	S50354000	1	ジシヤククミU	MAGNET ASSY, U	
4	S38082001	1	ハリウエジシヤククミ	NEEDLE UPPER MAGNET ASSY, U	
5	062681412	2	ナベコ437-40X14	SCREW PAN SM4.37-40X14	
6	025680132	2	ヒラザガネシヨウ4.37	WASHER PLAIN S SM4.37	

HE-800A-501

T1. コントロールボックス関係 / Control box mechanism

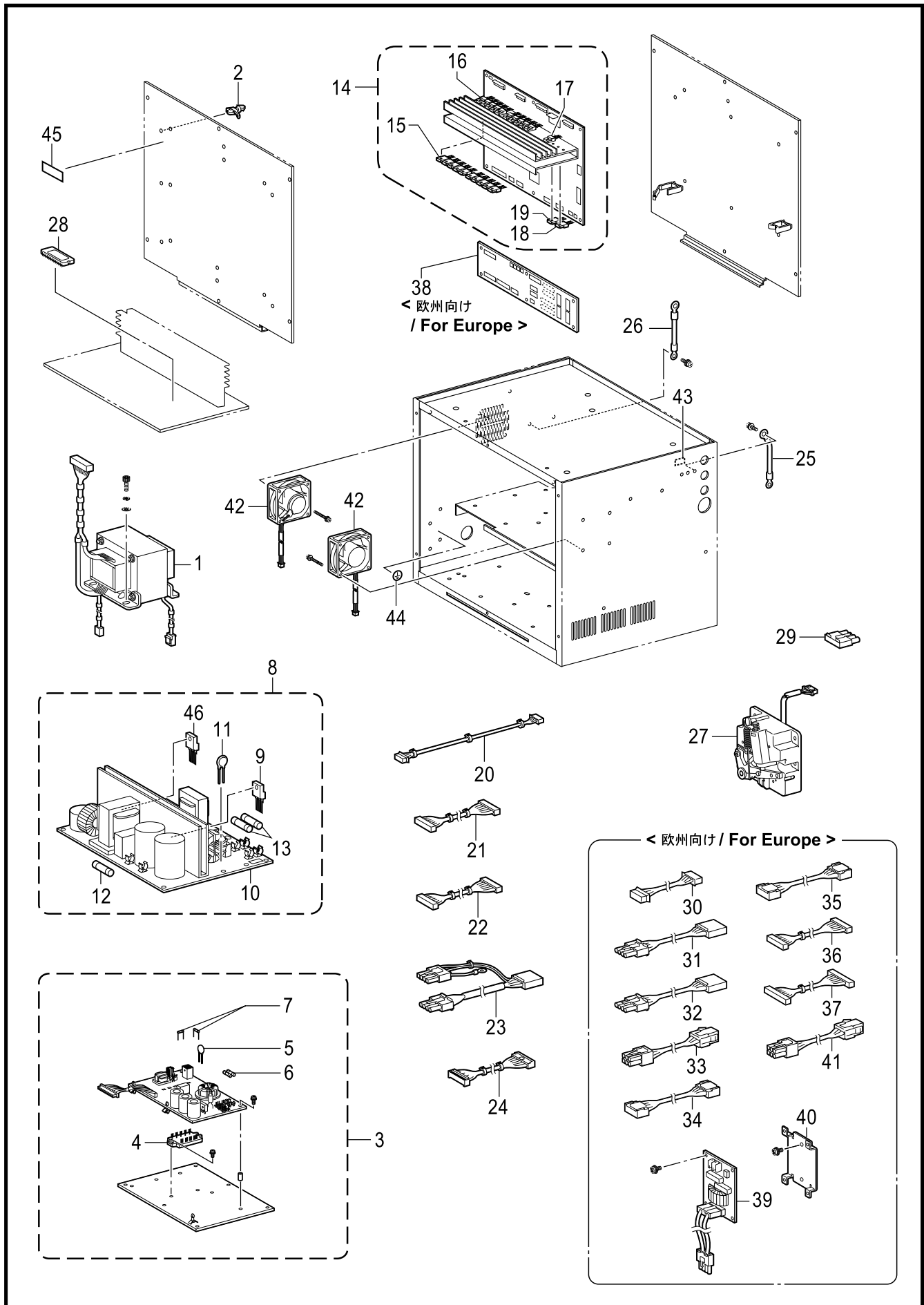

T1. コントロールボックス関係 / Control box mechanism

REF.NO	CODE	Q'TY	品名	NAME OF PARTS	RM
1	SA4024001	1	トランスクミ	TRANSFORMER ASSY	
2	S00554000	23	サポ-ト6NS	SUPPORT, 6NS	
3	S47721301	1	デンゲンEZキバンクミ	POWER SUPPLY PCB ASSY EZ	
4	J03466001	1	IPM 6MBP20RH060	IPM 6MBP20RH060-50	
5	S38201000	4	バリスタV14D471	VARISTOR: V14D471	
6	SA2870001	2	Gヒューズ15A	GLASS FUSE, 15A	
7	J02727001	2	カンヒューズ2A	GLASS FUSE 2A	
8	S50425101	1	デンゲンEHキバンクミ	POWER SUPPLY PCB ASSY EH	
9	S38200000	2	M0SFET2SK1938	TRANSISTOR, : 2SK1938	
10	232384001	1	SアブソバDSA362MA	SURGE ABSORBER: DSA362MA	
11	S38201000	2	バリスタV14D471	VARISTOR: V14D471	
12	S08030000	1	GFUSE5AFB	GLASS FUSE 5AFB	
46	SA8886001	1	DアレイD20LC40	DIODE AR: D20LC40	
13	SA2823001	2	ヒューズ 6A	FUSE, 6A	
14	S50431101	1	サブキバンクミ	SUB PCB ASSY	
15	SA6302001	10	FET2SJ350	TRANSISTOR, FET: 2SJ350	
16	SA6303001	10	FET2SK2202	TRANSISTOR, FET: 2SK2202	
17	S38155000	4	M0SFET2SK1306	TRANSISTOR, FET: 2SK1306	
18	S50645000	1	M0SFET2SK1307	TRANSISTOR, FET: 2SK1307	
19	S49486000	1	M0SFET2SJ222	TRANSISTOR, FET: 2SJ222	
20	S50437000	1	PERコード	CORD, PER	
21	S50438000	1	EX32ハーネス	HARNESS, EX32	
22	S50439000	1	EX26ハーネス	HARNESS, EX26	
23	SA8391001	1	デンゲンACハーネス	POWER SUPPLY HARNESS AC	
24	S50441000	1	デンゲンDCハーネス	POWER SUPPLY HARNESS DC	
25	S50484000	1	ア-スコード	GROUND WIRE	
26	S50644001	1	ア-スコード	GROUND WIRE	
27	J80814001	1	TREALE UNIT EZ	TREALE UNIT EZ	
42	SA3797001	2	DCファンモータクミ	DC-FAN MOTOR ASSY	
43	S37059001	1	PEマーク	LABEL, PE	
44	S37060001	2	ア-スマーク	LABEL, GROUNDING	
45	J04115001	2	ラベルカンデン6カコク	LABEL, ELEC. SHOCK 6 LANG.	
28	SA3101001	1	<中国向 単相220V, 三相380V用> PROMHE800AクミC	<For China, 1-Phase 220V and 3-Phase 380V AC> PROM ASSY C 800A	
28	SA3079001	1	<中国向以外> PROMHE800Aクミ	<Except for China > PROM ASSY, 800A	
29	S38146000	2	<100V, 110V, 380V, 400V用> コネクタ3191-04R	<For 100V, 110V, 380V and 400V AC> CONNECTOR: 3191-04R	
30	SA3189001	1	<230V,400V用,欧州向け> EMC-PERコード	<For 230V and 400V Europe> CORD EMC-PER	
31	SA3196001	1	EMC-EZACINハーネス	HARNESS EMC-EZACIN	
32	SA3195001	1	EMC-EZMTハーネス	HARNESS EMC-EZMT	
33	SA3921001	1	EMC-CUTTERハーネス	HARNESS EMC-CUTTER	
34	SA3193001	1	EMC-FTPMハーネス	HARNESS EMC-FTPM	
35	SA3192001	1	EMC-FDPMハーネス	HARNESS EMC-FDPM	
36	SA3191001	1	EMC-EX26ハーネス	HARNESS EMC-EX26	
37	SA3190001	1	EMC-EX32ハーネス	HARNESS EMC-EX32	
38	SA3176101	1	PH キバンクミ	PH PCB ASSY	
39	S50498001	1	ノイズフィルタEHクミ	NOISE FILTER ASSY EH	
40	S40620000	1	キバントリツケイタ	PCB SETTING PLATE	
41	SA3194001	1	EMC-NPMハーネス	HARNESS EMC-NPM	

< 三相200V用 / For 3-Phase 200V AC. >

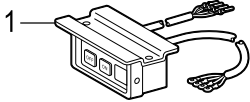

< 単相110V, 220V用  
/ For 1-Phase 110V, 220V AC. >

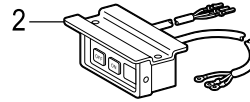

< 単相100V用, 日本向け / For 1-Phase 100V, Japan. >

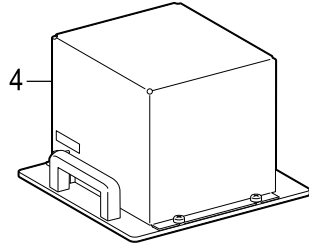
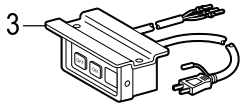

< 単相110V用 / For 1-Phase 110V AC. >

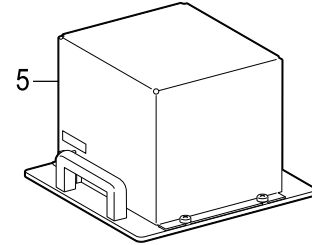
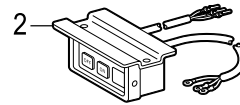

< 三相380V用 / For 3-Phase 380V AC. >

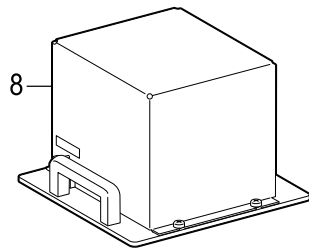
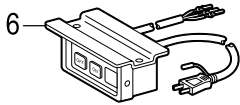

< 三相400V用 / For 3-Phase 400V AC. >

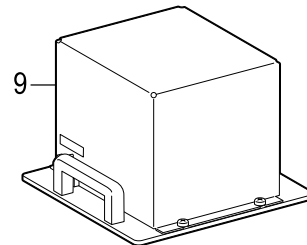

< 三相220V用 / For 3-Phase 220V AC. >

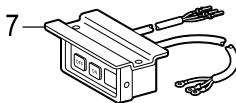



## T2. コントロールボックス関係 / Control box mechanism

REF.NO	CODE	Q'TY	品名	NAME OF PARTS	RM
1	S50442001	1	<三相200V用> デンゲンSWクミA	<For 3-Phase 200V AC> POWER SUPPLY SWITCH ASSY A	
2	S50444001	1	<单相110V, 220V用> デンゲンSWクミB	<For 1-Phase 110V,220V AC> POWER SUPPLY SWITCH ASSY B	
3	S50446001	1	<单相100V用,日本向け> デンゲンSWクミC	<For 1-Phase 100V,Japan> POWER SUPPLY SWITCH ASSY C	
4	SA3966001	1	<单相100V用,日本向け> トランスコンポウB1	<For 1-Phase 100V,Japan> TRANSFORMER PACKAGE ASSY B1	
5	SA3967001	1	<单相110V用> トランスコンポウB2	<For 1-Phase 110V AC> TRANSFORMER ASSY, B110: CONV.	
6	S50447001	1	<三相380V用> デンゲンSWクミD	<For 3-Phase 380V AC> POWER SUPPLY SWITCH ASSY D	
7	S50442001	1	<三相220V用> デンゲンSWクミA	<For 3-Phase 220V AC> POWER SUPPLY SWITCH ASSY A	
8	SA4020001	1	<三相380V用> ヘンカントランスC380クミ	<For 3-Phase 380V AC> TRANSFORMER ASSY C380 :CONV.	
9	SA3969001	1	<三相400V用> トランスコンポウE	<For 3-Phase 400V AC> TRANSFORMER PACKAGE ASSY E	

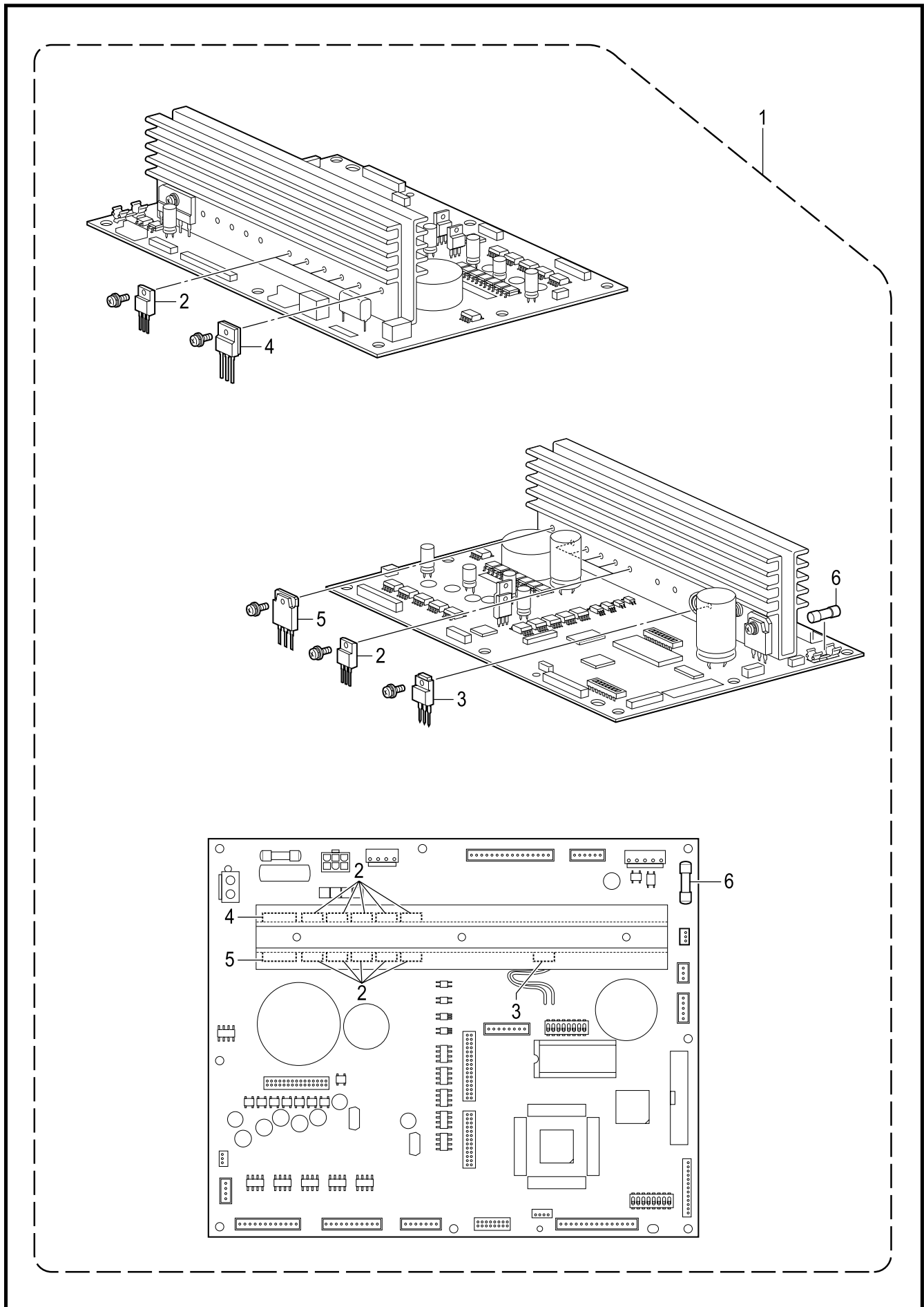

T3. コントロールボックス関係（電源基板） / Control box (PCB) mechanism

REF.NO	CODE	Q'TY	品名	NAME OF PARTS	RM
1	S53902301	1	ホキユウメインキバンクミ	SUPPLY MAIN PCB ASSY	
2	S46455000	10	FETFK10KM-10	TRANSITOR, FET: FK10KM-10	
3	S38155000	1	M0SFET2SK1306	TRANSISTOR, FE: 2SK1306	
4	S38200000	1	M0SFET2SK1938	TRANSISTOR, : 2SK1938	
5	S47668000	1	SIDPA905C6	DIODE, AR: PA905C6	
6	S47680000	1	GFUSE8A	GLASS FUSE, 8A	

HE-800A-518

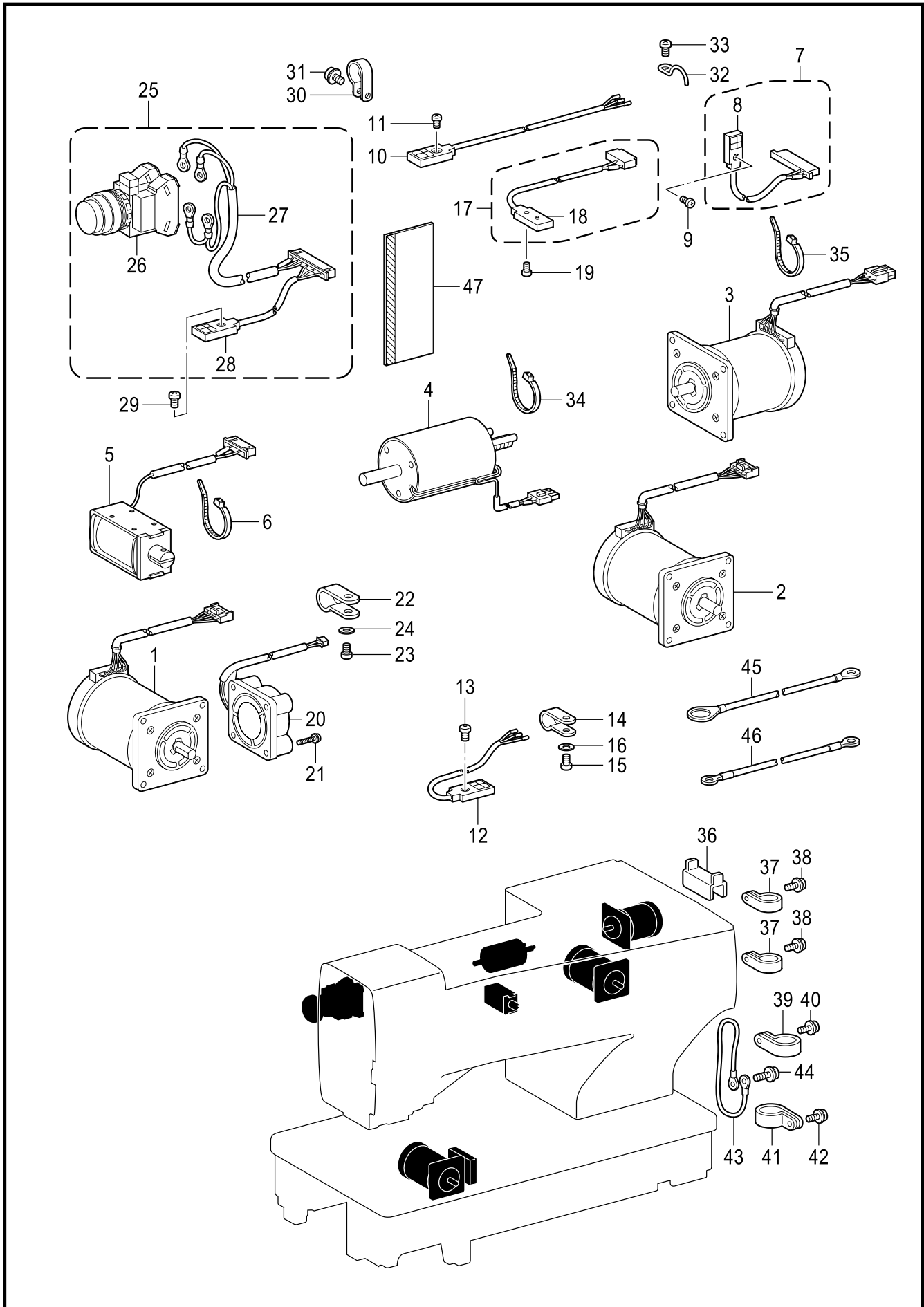

U. 電装品関係 / Power supply equipment mechanism

REF.NO	CODE	Q'TY	品名	NAME OF PARTS	RM
1	S50458100	1	パルスモータFDクミ	PULSE MOTOR ASSY FD	
2	S50459100	1	パルスモータFTクミ	PULSE MOTOR ASSY FT	
3	S50460000	1	パルスモータNクミ	PULSE MOTOR ASSY N	
4	S50461000	1	カッターソレノイド	CUTTER SOLENOID	
5	S50462000	1	イトユルメソレノイド	TENSION RELEASE SOLENOID	
6	228475000	1	ケツソクバンド1.9X80	FASTENING BAND 1.9X80	
7	S50463000	1	センサクミ	SENSOR ASSY	
8	S50464000	1	センサGL-N12	SENSOR, GL-N12	
9	062300806	1	ナベコ3X8	SCREW PAN M3X8	
10	S50465000	1	センサGL-N12	SENSOR, GL-N12	
11	062300806	1	ナベコ3X8	SCREW PAN M3X8	
12	S50464000	1	センサGL-N12	SENSOR, GL-N12	
13	062300806	1	ナベコ3X8	SCREW PAN M3X8	
14	625010000	1	ナイロンクランプNK-2N	NYLON CLAMP NK-2N	
15	062670812	1	ナベコ357-40X8	SCREW PAN SM3.57-40X8	
16	025350132	1	ヒラザガネシヨウ3.5	WASHER PLAIN S 3.5	
17	S50466000	1	カッターセンサクミ	CUTTER SENSOR ASSY	
18	S50467000	1	センサGL-N12	SENSOR, GL-N12	
19	062300806	1	ナベコ3X8	SCREW PAN M3X8	
20	S50468000	1	DCファンモータ40クミ	DC FAN MOTOR ASSY 40	
21	0A5302005	2	+ナベザクミ3X20DB	SCREW PAN (S/P WASHER) M3X20	
22	S00480000	3	コードホルダ#5	CORD HOLDER 5N	
23	062670612	3	ナベコ357-40X6	SCREW PAN SM3.57-40X6	
24	025350132	3	ヒラザガネシヨウ3.5	WASHER PLAIN S 3.5	
25	SA3113001	1	テシSWハーネスクミ	STOP SWITCH HARNESS ASSY	
26	SA7488001	1	スイッチHW1B-M211B	SWITCH HW1B-M211B	
27	S50472000	1	EMSWハーネス	SWITCH HARNESS EM	
28	S50473000	1	センサGL-N12	SENSOR, GL-N12	
29	062300806	1	ナベコ3X8	SCREW PAN M3X8	
30	S10243000	4	ナイロンクランプNK-3N	CORD HOLDER: NK-3N	
31	0A5400806	4	+ナベザクミ4X8DB	SCREW PAN (S/P WASHER) M4X8	
32	152969001	1	コードササエカネ	CORD HOLDER	
33	002300603	1	+ナベコ3X6	SCREW, PAN M3X6	
34	228475000	2	ケツソクバンド1.9X80	FASTENING BAND 1.9X80	
35	218859001	1	バインダM150	BINDER M150	
36	S50565001	1	コードブツシュ	CORD BUSH	
37	552907000	2	コードホルダ#10	CORD HOLDER #10	
38	0A5401006	2	+ナベザクミ4X10DB	SCREW PAN (S/P WASHER) M4X10	
39	552908000	1	コードホルダ#14	CORD HOLDER #14	
40	0A5401006	1	+ナベザクミ4X10DB	SCREW PAN (S/P WASHER) M4X10	
41	552908000	1	コードホルダ#14	CORD HOLDER #14	
42	0A5401006	1	+ナベザクミ4X10DB	SCREW PAN (S/P WASHER) M4X10	
43	S38145000	1	アースセン2	GROUND WIRE 2	
44	0A5401006	2	+ナベザクミ4X10DB	SCREW PAN (S/P WASHER) M4X10	
45	S41216000	1	アースセン	GROUND WIRE	
46	S50644000	1	アースコード	GROUND WIRE	
47	SA0287000	1	クイツクチューブ30X350	QUICK TUBE ASSY, 30X350	

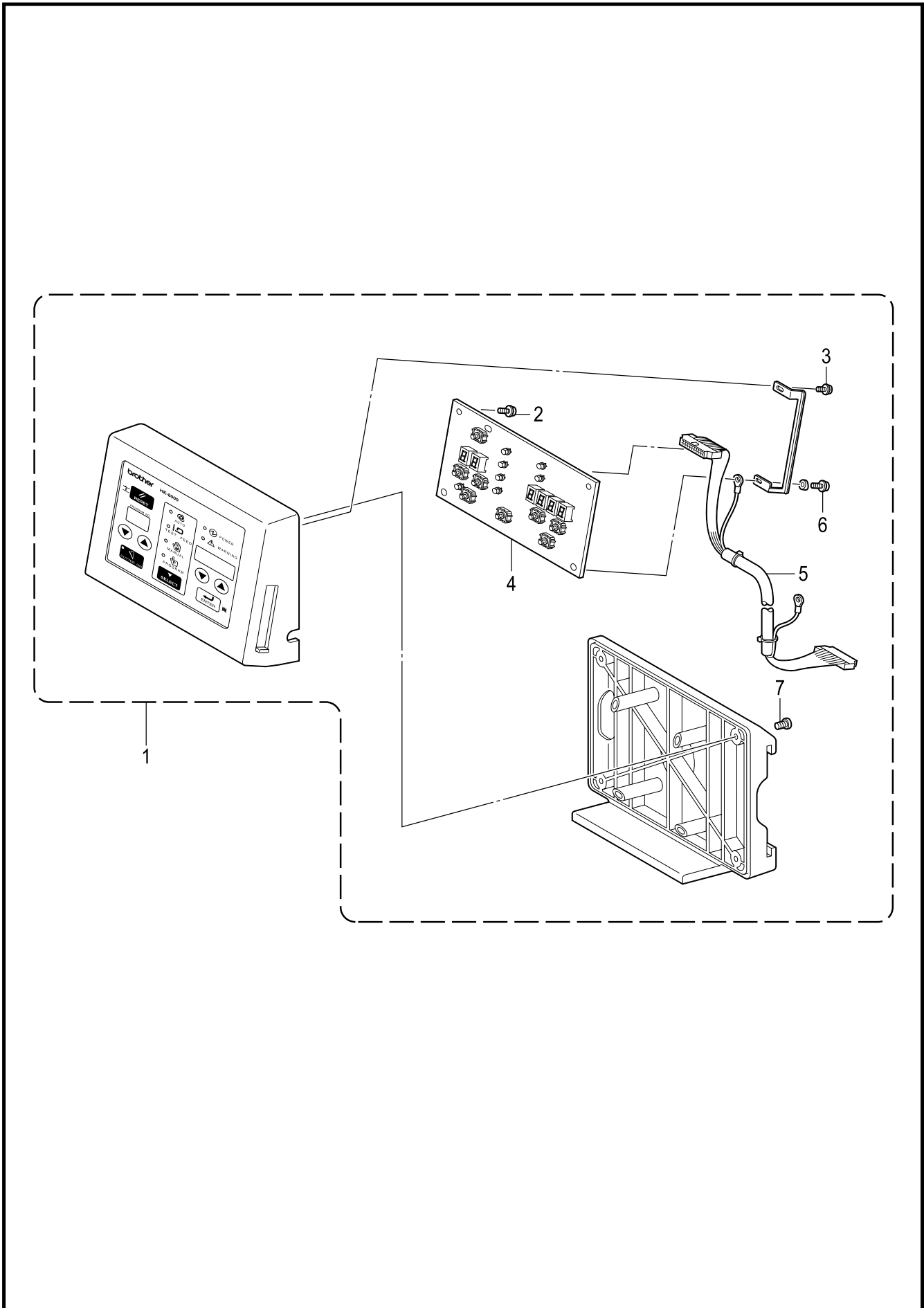

V. 操作パネル関係 / Operation panel mechanism

REF.NO	CODE	Q'TY	品名	NAME OF PARTS	RM
1	SA3081001	1	ソウサパネルソウクミ	OPERATION PANEL UNIT	
2	087310816	2	カツプBタイト3X8	TAPTITE CUP B M3X8	
3	0A4400606	1	+ナベザクミ4X6DA	SCREW PAN (S/P WASHER) M4X6	
4	S50453100	1	パネルキバンクミ	PANEL PCB ASSY	
5	S50457000	1	パネルケーブルクミ	PANEL CABLE ASSY	
6	087311016	2	カツプBタイト3X10	TAPTITE CUP B M3X10	
7	062300806	4	ナベコ3X8	SCREW PAN M3X8	

HE-800A-530

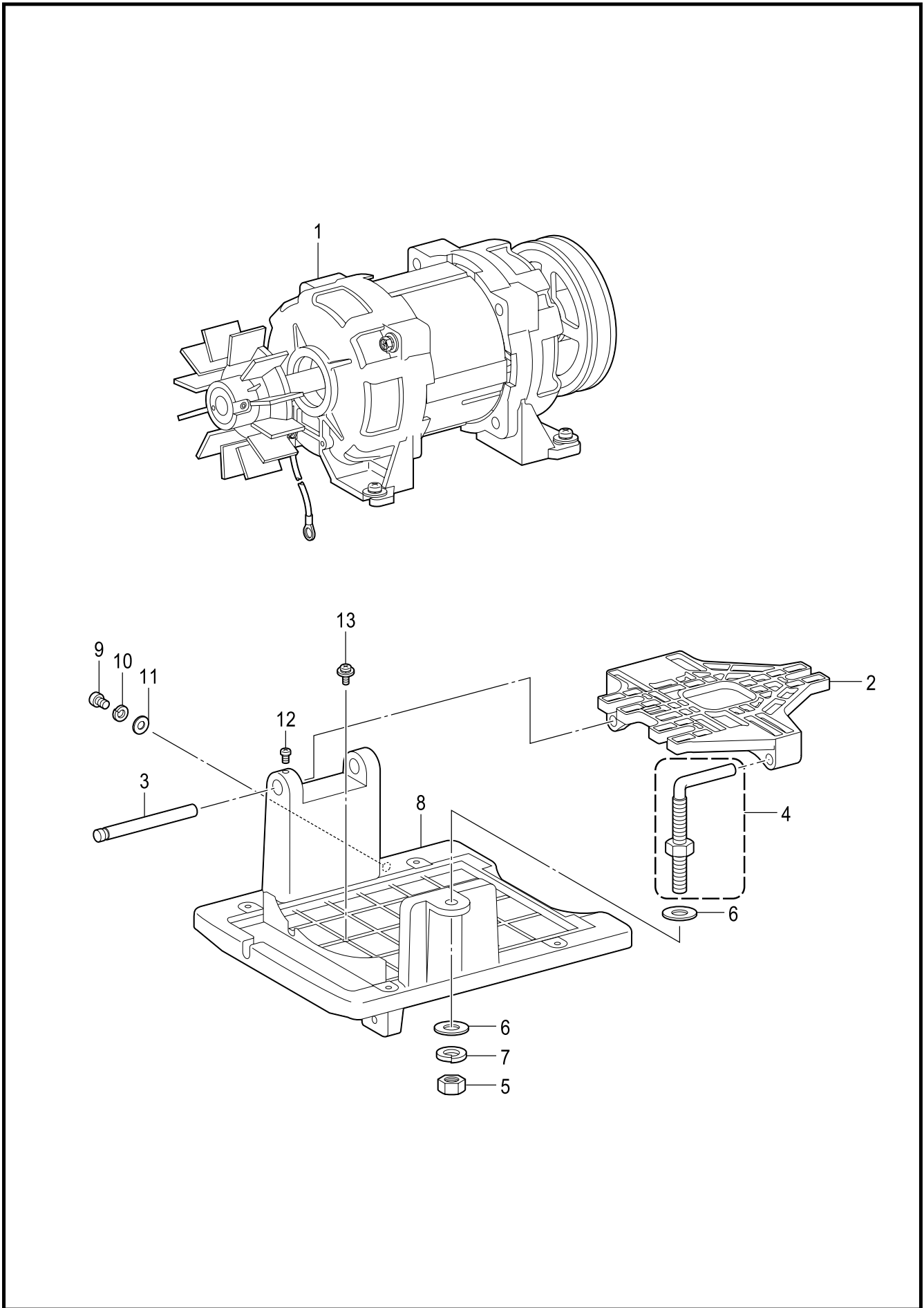



## W. モーター関係 / Motor mechanism

REF.NO	CODE	Q'TY	ヒンメイ	NAME OF PARTS	RM
1	J80863001	1	INVモータクミ#EHホキユウ	MOTOR ASSY, INV#EH	
2	J00107001	1	MD806コテイダイ#2	MD806 BASE #2	
3	J02517001	1	ピン9.9X116	PIN, 9.9X116	
4	J03275001	1	Lガタボルト10クミ-V	BOLT ASSY, L M10-V	
5	021100206	1	2シユナツト10	NUT, 2 M10	
6	025100236	2	ヒラザガネチユウ10	WASHER, PLAIN L 10	
7	028100246	1	バネザガネ2-10	WASHER, SPRING 2-10	
8	J03410001	1	EZ モータリツケイタ	SETTING PLATE, EZ-MOTOR	
9	062401063	1	ナベコ4X10	SCREW, PAN M4X10	
10	028040245	1	バネザガネ2-4	WASHER, SPRING 2-4	
11	025040173	1	ヒラザガネシヨウ4	WASHER, PLAIN S 4	
12	002401006	1	+ナベコ4X10	SCREW, PAN M4X10	
13	215082001	1	+ナベセット4X12DA	SCREW 4 X 12	

HE-800A-631

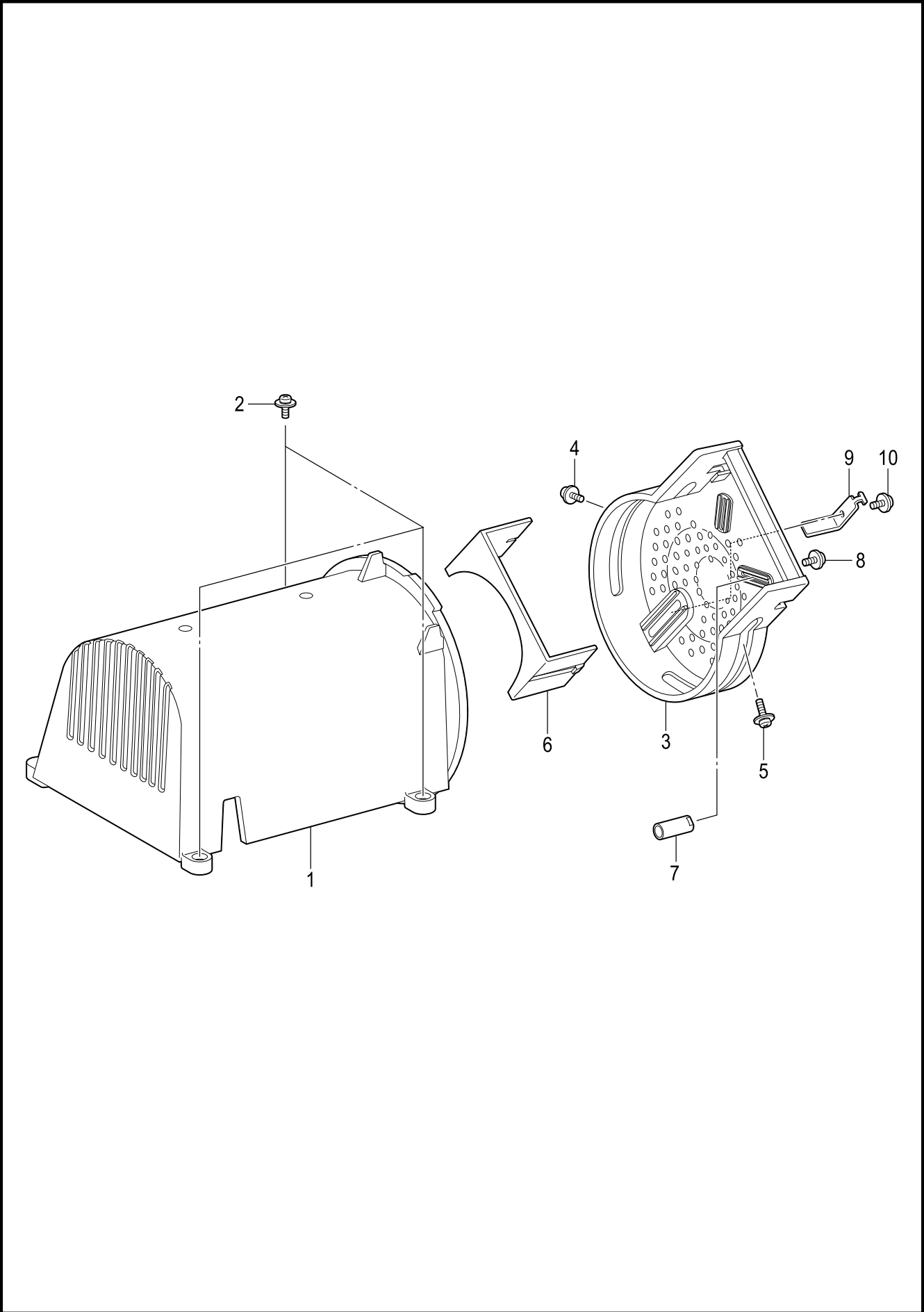

X. カバー関係 / Safety cover

REF.NO	CODE	Q'TY	ヒンメイ	NAME OF PARTS	RM
1	J02513001	1	モータカバー-INV	MOTOR COVER, INV	
2	0A4401605	3	+ナベザクミ4X16DA	SCREW, PAN (S/P WASHE) M4X16	
3	J03763001	1	ベルトカバー-LCM	BELT COVER	
4	229017001	1	+ナベセット4X10DA	SCREW, PAN (S/P WASHER) M4X10	
5	217071001	1	+ナベセット4X18DA	SCREW 4X18DA	
6	J03764001	1	ベルトSカバー-LCM	BELT SUB COVER	
7	J02293001	1	ユビホゴグ	FINGER PROTECTION BAR	
8	229017001	1	+ナベセット4X10DA	SCREW, PAN (S/P WASHER) M4X10	
9	J00351001	1	ベルトハズレボウシグ2	BELT CLAMP PLATE 2	
10	229017001	1	+ナベセット4X10DA	SCREW, PAN (S/P WASHER) M4X10	

HE-800A-631

< 布帛用 / For General materials >

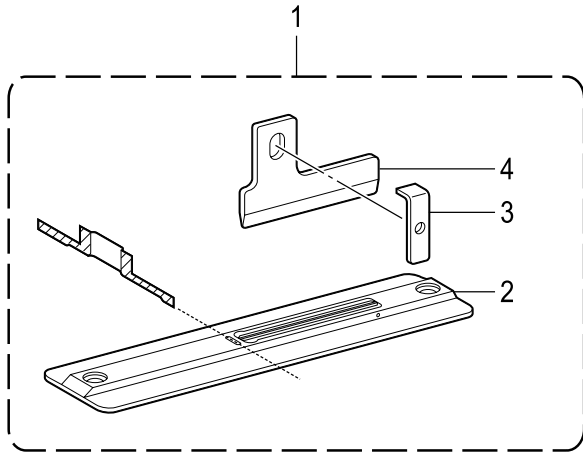

< ニット用 / For Knitted materials >

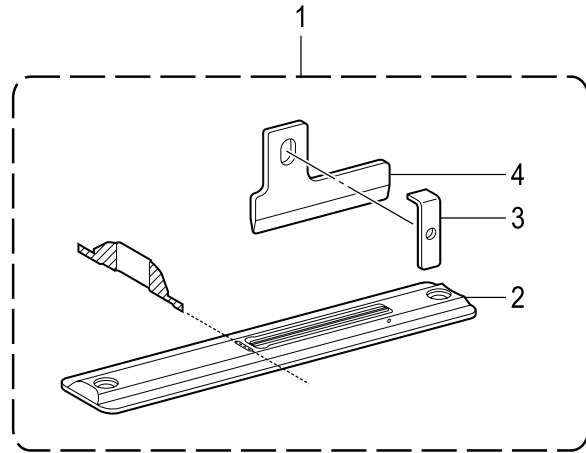

< 立作業用 / For Standing operation >

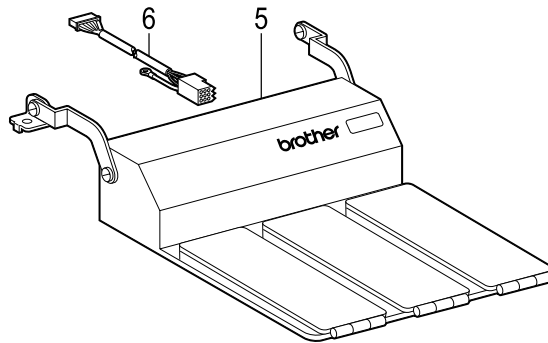

Y. 付属装置関係（オプション部品） / Attachment set (Option parts)

REF.NO	CODE	Q'TY	品名	NAME OF PARTS	RM
			<布帛用>	<For General materials>	
			<針穴: 1.2X5.4mm>	<Needle hole: 1.2X5.4mm>	
1	S51361001	1	ハリイタ1.2RBセット	NEEDL PLATE SET, 1.2RB	
2	S50304001	1	ハリイタ1.2S-RBクミ	NEEDLE PLATE ASSY, 1.2S-RB	
3	S50297001	1	カッター-オサエ	CUTTER HOLDER	
4	S50341001	1	カッター-ホルダイチギメイタ	POSITIONING PLATE	
			<針穴: 1.4X7.3mm>	<Needle hole: 1.4X7.3mm>	
1	S51362001	1	ハリイタ1.4RBセット	NEEDLE PLATE SET, 1.4RB	
2	S50309001	1	ハリイタ1.4S-RBクミ	NEEDLE PLATE ASSY, 1.4S-RB	
3	S50297001	1	カッター-オサエ	CUTTER HOLDER	
4	S50341001	1	カッター-ホルダイチギメイタ	POSITIONING PLATE	
			<針穴: 1.6X7.3mm>	<Needle hole: 1.6X7.3mm>	
1	S51363001	1	ハリイタ1.6RBセット	NEEDLE PLATE SET, 1.6RB	
2	S50311001	1	ハリイタ1.6S-RBクミ	NEEDLE PLATE ASSY, 1.6S-RB	
3	S50297001	1	カッター-オサエ	CUTTER HOLDER	
4	S50341001	1	カッター-ホルダイチギメイタ	POSITIONING PLATE	
			<ニット用>	<For knitted materials>	
			<針穴: 1.2X5.4mm>	<Needle hole: 1.2X5.4mm>	
1	S51364001	1	ハリイタ1.2RB-3セット	NEEDLE PLATE SET, 1.2RB-3	
2	S50313101	1	ハリイタ1.2S-RBクミ-3	NEEDLE PLATE ASSY, 1.2-RB-3	
3	S50297001	1	カッター-オサエ	CUTTER HOLDER	
4	S50341001	1	カッター-ホルダイチギメイタ	POSITIONING PLATE	
			<針穴: 1.4X6.8mm>	<Needle hole: 1.4X6.8mm>	
1	S51365001	1	ハリイタ1.4RB-3セット	NEEDLE PLATE SET, 1.4RB-3	
2	S50317101	1	ハリイタ1.4S-RBクミ-3	NEEDLE PLATE ASSY, 1.4S-RB-3	
3	S50297001	1	カッター-オサエ	CUTTER HOLDER	
4	S50341001	1	カッター-ホルダイチギメイタ	POSITIONING PLATE	
			<針穴: 1.6X6.8mm>	<Needle hole: 1.6X6.8mm>	
1	S51366001	1	ハリイタ1.6RB-3セット	NEEDLE PLATE SET, 1.6RB-3	
2	S50319101	1	ハリイタ1.6S-RBクミ-3	NEEDLE PLATE ASSY, 1.6S-RB-3	
3	S50297001	1	カッター-オサエ	CUTTER HOLDER	
4	S50341001	1	カッター-ホルダイチギメイタ	POSITIONING PLATE	
			<立作業用: 欧州向以外>	<For Standing operation: except for Europe>	
5	J80380040	1	DDタチペタル3Pカヘン40	PEDAL STAND OPE DD 3P VARI 40	
			<立作業用: 欧州向>	<For Standing operation: for Europe>	
5	J803800E0	1	DDタチペタル3Pカヘン40	PEDAL STAND OPE DD 3P VARI 40	
6	S47750000	1	タチペタルヨウハーネス	S-OPE. HARNESS	

Z1 . 付属品関係 / Accessories

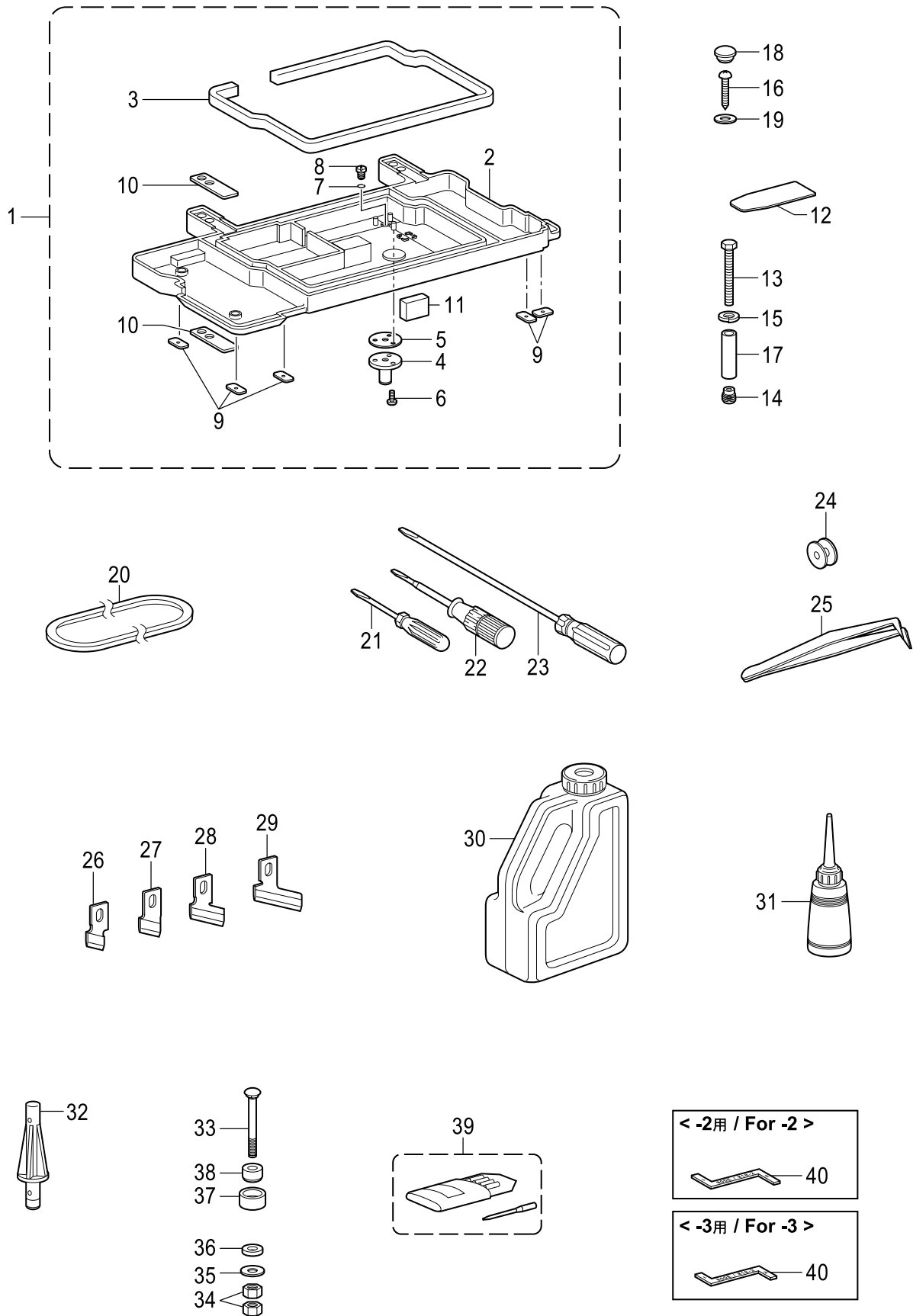

## Z1. 付属品関係 / Accessories

REF.NO	CODE	Q'TY	品名	NAME OF PARTS	RM
1	S50330101	1	ベッドダイクミ	BED BASE ASSY	
2	S50331000	1	ベットダイ	BED BASE	
3	S50332000	1	オイルパツキン	OIL PACKING	
4	S54768001	1	アブラトリダシイタ	DRAIN PLATE	
5	S50334000	1	アブラトリダシパツキン	PACKING	
6	037401415	3	Vナベタツピン4X14	TAPPING SCREW PAN V M4X14	
7	081007070	1	OリングP7	O RING P7	
8	140518001	1	シメネジ7.94	SCREW, SM7.94X10	
9	S50335000	5	ベットダイクツシヨナ	BED BASE CUSHION, A	
10	S50336000	4	ベットダイクツシヨナB	BED BASE CUSHION, B	
11	S50337000	2	ベットダイクツシヨナC	BED BASE CUSHION, C	
12	S50338000	1	アブラヨケイタ	OIL STOPPER PLATE	
13	S24250001	4	ボルト8X90	BOLT M8X90	
14	S50342000	4	オニメナツト8	FLANGE NUT, M8	
15	028080246	4	バネザガネ2-8	WASHER SPRING 2-8	
16	101118001	3	マルモクネジ4.5X20	WOOD SCREW, ROUND M4.5X20	
17	S50339001	4	ベットダイカラ-	COLLAR	
18	104449001	2	ゴムセン15.5	RUBBER CAP, 15.5	
19	025050236	3	ヒラザガネチュウ5	WASHER PLAIN M 5	
20	S18707153	1	VベルトMシロ	BELT, VM WHITE	
21	142443001	1	ネジマワシ1.9X52	SCREW-DRIVER, 1.9X52	
22	118837001	1	ネジマワシ3.4X70	SCREW-DRIVER, 3.4X70	
23	101572102	1	ネジマワシ5.5X190	SCREW-DRIVER 5.5X190	
24	159158051	1	ボビン	BOBBIN	
25	117466000	1	ピンセット	PINCETTE	
26	S51290001	1	カツタ3/8	CUTTER, 3/8	
27	S51354001	1	カツタ5/8	CUTTER, 5/8	
28	S51358001	1	カツタ1	CUTTER, 1	
29	S51356001	1	カツタ3/4	CUTTER, 3/4	
30	S55663001	1	オイルタンククミ	OIL TANK ASSY	
31	114483002	1	ポリオイラークミ	OILER ASSY	
32	159384009	1	トウブササエマクラ	HEAD REST	
			<コントロールボックス取付用>	<For setting the Control box>	
33	133740006	4	カクネボルト6X70	BOLT SQUARE M6X70	
34	021060106	8	1シュナツト6	NUT 1 M6	
35	025060336	4	ヒラザガネダイ6	WASHER PLAIN L 6	
36	S00617000	4	ボウシンゴムカラ-	RUBBER COLLAR	
37	146256001	4	クツシヨナカナグ	CUSHION COLLAR	
38	146255000	4	クツシヨナ	CUSHION	
			<-2用>	<For -2>	
39	SA9254014	1	SA9253ハリ4コイリクミ:#14 NM90	NEEDLE 4PIECE ASSY SA9253: #14 NM90	
40	S13595201	1	デアイゲージ-2	TIMING GAUGE, -2	
			<-3用>	<For -3>	
39	SA9254011	1	SA9253ハリ4コイリクミ:#11 NM75	NEEDLE 4PIECE ASSY SA9253: #11 NM75	
40	S13596201	1	デアイゲージ-3	TIMING GAUGE, -3	

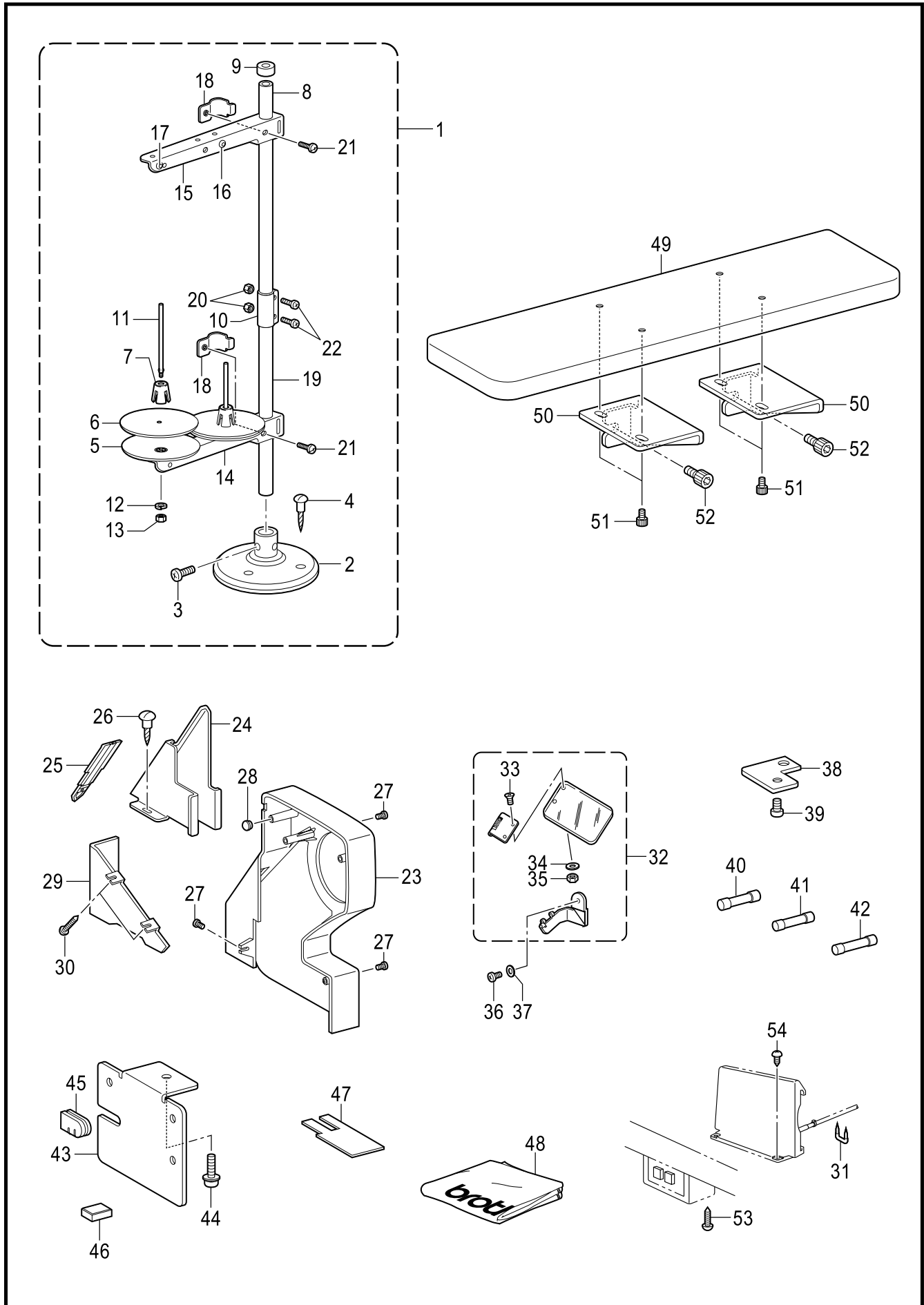



## Z2. 付属品関係 / Accessories

REF.NO	CODE	Q'TY	品名	NAME OF PARTS	RM
1	S02761509	1	イトタテダイクミ2	COTTON STAND ASSY 2	
2	150189109	1	ブラケット	COTTON STAND BRACKET	
3	062060804	2	ナベコ6X8	SCREW PAN M6X8	
4	031452204	3	マルモク45X22	WOOD SCREW ROUND M4.5X22	
5	S51283001	2	ウケザラ	SPOOL STAND BASE	
6	150182000	2	スプールマット	SPOOL MAT	
7	S51282101	2	スプールのクッション	SPOOL CUSHION	
8	150172003	1	コラムパイプ	COLUMN PIPE	
9	150174000	1	コラムキャップ	COLUMN CAP	
10	SA6606001	1	コラムジョイント	COLUMN JOINT	
11	150179002	2	スプールジグB	SPOOL SHAFT B	
12	028050244	2	バネザガネ2-5	WASHER SPRING 2-5	
13	021500104	2	1シュナット5	NUT 1 M5	
14	SA6607001	1	スプールホルダー-2	SPOOL HOLDER 2	
15	SA6607001	1	スプールホルダー-2	SPOOL HOLDER 2	
16	150183000	2	イトカケハンガーダイ	THREAD HANGER BASE	
17	142990001	2	スレツドブツシュ	THREAD BUSH	
18	SA6609001	2	スプールホルダー-ササエ	SPOOL HOLDER SUPPORTER	
19	150172003	1	コラムパイプ	COLUMN PIPE	
20	021500104	2	1シュナット5	NUT 1 M5	
21	062061604	2	ナベコ6X16	SCREW PAN M6X16	
22	062501404	2	ナベコ5X14	SCREW PAN M5X14	
23	SA9157001	1	ベルトカバー	BELT COVER	
24	SA9158001	1	ベルトカバー-D	BELT COVER D	
25	SA9159001	1	ベルトカバー-Dフタ	BELT COVER D PLATE	
26	100666002	2	マルモクネジ5.5X20	WOOD SCREW, ROUND M5.5X20	
27	SA3025001	3	ナベザクミ4X10DA	SCREW PAN (S/P WASHER) M4X10	
28	104450101	2	ゴムセン8	RUBBER CAP, 8	
29	S50344001	1	ベルトカバー-イタ	BELT COVER PLATE	
30	032461606	2	+2マルモク45X16	WOOD SCREW ROUND 2 M4.5X16	
31	200190001	6	ステツブル 10X20	STAPLE 10X20	
32	S37111001	1	アイガードクミ	EYE GUARD ASSY	
33	S01700001	2	マルサラネジ3.18X7	SCREW, OVAL SM3.18X7	
34	025030232	2	ヒラザガネネチュウ3	WASHER PLAIN M 3	
35	021660102	2	1シュナット318-40	NUT 1 SM3.18-40	
36	062710612	1	ナベコ476-32X6	SCREW PAN SM4.76-32X6	
37	148847001	1	ザガネ	WASHER PLAIN 4.76	
38	S50345001	1	アイガードササエイタ	EYE GUARD SUPPORT	
39	062680812	1	ナベコ437-40X8	SCREW PAN SM4.37-40X8	
40	SA2870001	2	GFUSE15A	GLASS FUSE 15A	
41	S08030000	1	GFUSE5AFB	GLASS FUSE 5AFB	
42	153242000	2	GFUSE6A	GLASS FUSE 6A	
43	J03411001	1	EZフミコミトリツケイタ	SETTING PLATE, EZ-TREADLE	
44	J00353001	3	+ナベセット5X14DB	SCREW PAN (S/P WASHER) M5X14	
45	J02036001	1	テモトコードブツシングV	BUSHING, V CORD	
46	112525000	1	シュウジンマグネット	MAGNET	
47	S54767000	1	ホジヨシート	AUXILIARY SHEET	
48	144226001	1	トウブカバー	HEAD COVER	
49	SA9160001	1	ホジヨテーブル	AUXILIARY TABLE	
50	SA9161001	2	テーブルササエイタ	TABLE SUPPORT PLATE	
51	018400636	2	アナボルト4X6	BOLT SOCKET M4X6	
52	018061036	2	アナボルト6X10	BOLT SOCKET M6X10	
53	032461606	2	<電源スイッチ取付用> +2マルモク45X16	<For setting the Power supply switch> WOOD SCREW ROUND 2 M4.5X16	
54	031412506	4	<操作パネル取付用> マルモク41X25	<For setting the Opreation panel> WOOD SCREW ROUND M4.1X25	

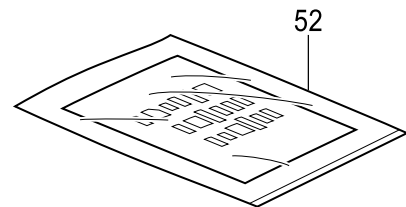
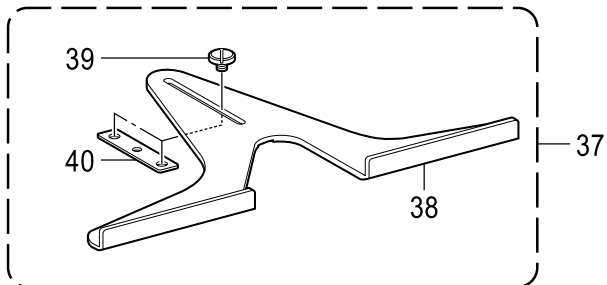
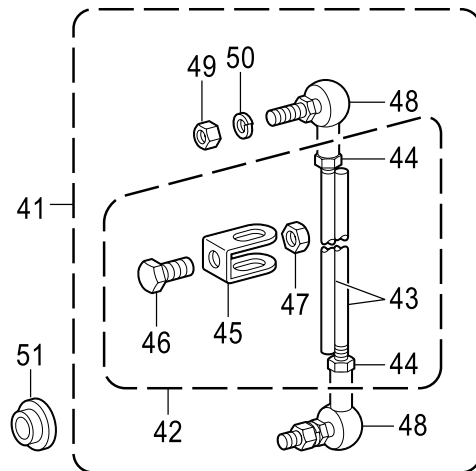
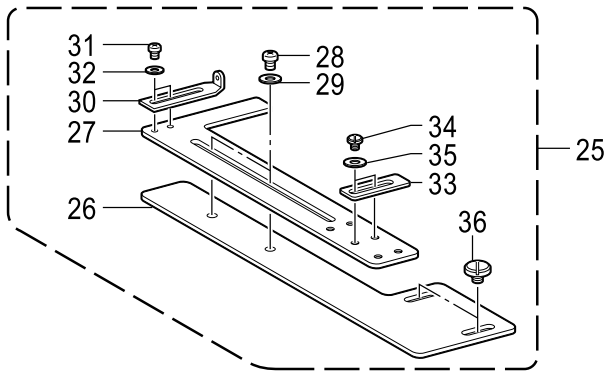
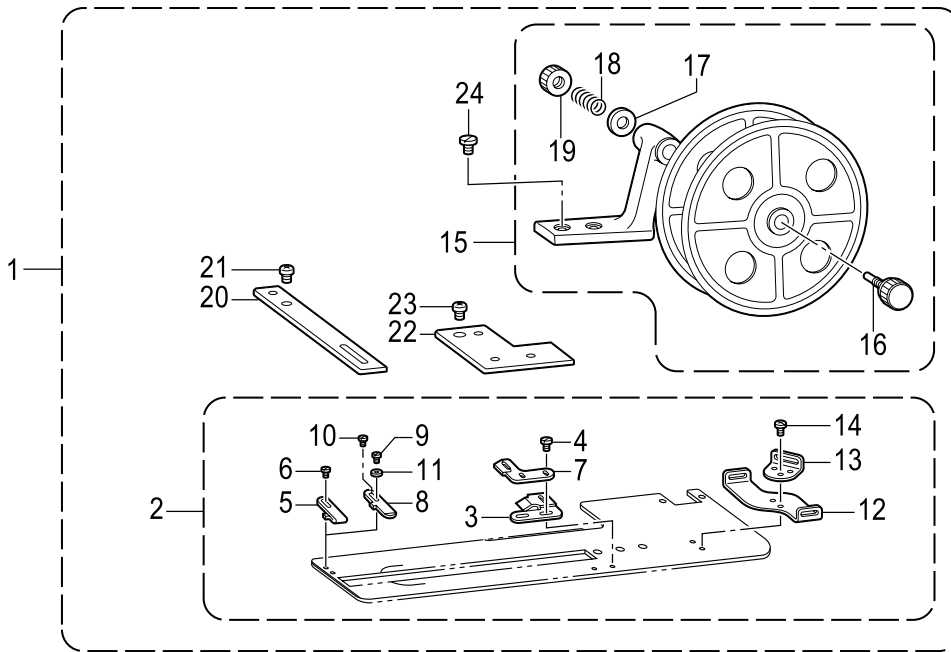

## Z3. 付属品関係 / Accessories

REF.NO	CODE	Q'TY	品名	NAME OF PARTS	RM
			<オプション用>	<OPTION PARTS>	
1	S50346001	1	テープオサエワインダークミ	TAPE GUARD WINDER ASSY	
2	S51896001	1	テープオサエクミ	TAPE GUARD ASSY	
3	144998001	1	テープオサエB	TAPE GUARD, B	
4	105288002	2	シメネジ2.38	SCREW SM2.38	
5	144997001	1	テープオサエA	TAPE GUARD, A	
6	122771051	2	シメネジ2.38	SCREW, SM2.38	
7	144999001	1	テープオサエC	TAPE GUIDE, C	
8	144628001	1	テープオサエF	TAPE GUARD, F	
9	122771051	1	シメネジ2.38	SCREW, SM2.38	
10	105970001	1	シメネジ2.38	SCREW, SM2.38	
11	110067001	1	カラ	COLLAR	
12	143749001	1	テープアンナイシタ	TAPE GUIDE, LOWER	
13	143748001	1	テープアンナイウエ	TAPE GUIDE, UPPER	
14	062660412	2	ナベコ318-40X4	SCREW PAN SM3.18-40X4	
15	143767102	1	テープワインダークミ	TAPE WINDER ASSY	
16	143980001	1	ツマミネジ	SCREW	
17	108494001	1	ザガネ	WASHER	
18	108495001	1	テープワインダオシバネ	SPRING, COMPRESSION	
19	100136001	1	イトチヨウシナツト	TENSION NUT	
20	S50348001	1	テープアンナイウエ	TAPE GUIDE, U	
21	062400812	1	ナベコ4X8	SCREW PAN M4X8	
22	S50349001	1	テープワインダトリツケイタ	TAPE WINDER SETTING PLATE	
23	062400812	1	ナベコ4X8	SCREW PAN M4X8	
24	107407003	2	シメネジ4.37	SCREW, SM4.37X9	
25	S50477001	1	ジヨウギクミ	RULER ASSY	
26	S06139001	1	ジヨウギA	RULER, A	
27	S06140001	1	ジヨウギB	RULER, B	
28	062680512	2	ナベコ437-40X5	SCREW PAN SM4.37-40X5	
29	025680232	2	ヒラザガネチューウ4.37	WASHER PLAIN M SM4.37	
30	146000001	1	ハサミササエ	THREAD TRIMMER SUPPORT	
31	062670412	2	ナベコ357-40X4	SCREW PAN SM3.57-40X4	
32	105161003	2	ザガネ	WASHER, PLAIN	
33	141620001	1	ボウシイタバランス	BALANCER	
34	101671002	2	シメネジ4.37	SCREW, SM4.37	
35	025680132	2	ヒラザガネショウウ4.37	WASHER PLAIN S SM4.37	
36	S36522001	2	シメネジ4.37	SCREW, SM4.37	
37	S50350001	1	ジヨウギクミ800E	RULER ASSY, 800E	
38	S50476001	1	ヨコジヨウギ	RULER	
39	S36522001	2	シメネジ4.37	SCREW, SM4.37	
40	S50351001	1	ヨコジヨウギスペーサー	RULER SPACER	
41	133797121	1	レンケツカンクミ	CONNECTING ROD ASSY	
42	119710021	1	レンカン クミ	CONNECTING ROD ASSY	
43	119711021	2	レンカン	CONNECTING ROD	
44	S36119021	2	1シユナツト6	NUT 1 M6	
45	119101021	1	レンカンダキ	CONNECTING ROD CLAMP	
46	S36114021	1	ボルト8X16	BOLT M8X16	
47	S36120021	1	ナツト1シユ8	NUT 1 M8	
48	133792121	2	ジヨイントクミ	JOINT ASSY	
49	S36119021	2	1シユナツト6	NUT 1 M6	
50	S36121021	2	バネザガネ2-6	WASHER SPRING 2-6	
51	114859001	1	レンカンカラ	COLLAR	
52	S55361200	1	パネルラベルフクロイリ	PANEL LABEL	

HE-800A-910











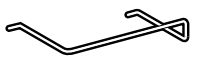
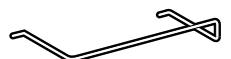
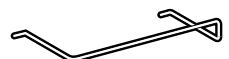

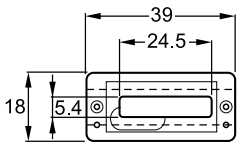

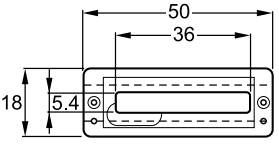

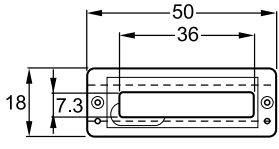
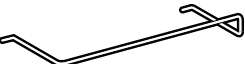

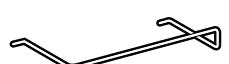
Ga1 . ゲージ部品一覧表 / Gauge parts list

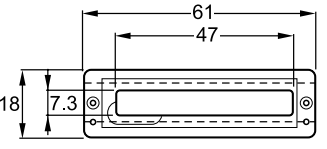
カッター / Cutter

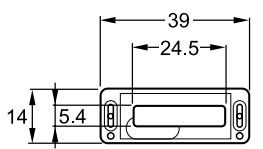
<p>S51117-001</p> <p>6.4 6 1/4 F 19 34.5</p> <p>1/4</p>	<p>S51290-001</p> <p>9.5 10 3/4 K 19.1 34.5</p> <p>3/8</p>	<p>S51351-001</p> <p>11.1 11 7/16 J 19.1 34.5</p> <p>7/16</p>	<p>S51352-001</p> <p>12.7 13 1/2 L 19.1 34.5</p> <p>1/2</p>	<p>S51353-001</p> <p>14.3 14 9/16 V 19.1 34.5</p> <p>9/16</p>	<p>S51354-001</p> <p>15.9 16 5/8 M 19 34.5</p> <p>5/8</p>
<p>S51355-001</p> <p>17.5 18 11/16 A 19 34.5 11</p> <p>11/16</p>	<p>S51356-001</p> <p>19.1 19 3/4 N 19 34.5 10.8</p> <p>3/4</p>	<p>S25642-001</p> <p>20.6 21 13/16 G 19 34.1 11.1</p> <p>13/16</p>	<p>S51357-001</p> <p>22.2 22 7/8 P 19 34.5 11</p> <p>7/8</p>	<p>S51358-001</p> <p>25.4 25 1 Q 19 34.5 10.5</p> <p>1</p>	
<p>S51359-001</p> <p>28.6 29 1 1/8 R 19 34.5 10</p> <p>29</p>		<p>S51360-001</p> <p>31.8 32 1 1/8 S 20.7 34.8 11.2</p> <p>32</p>		<p>S01271-001</p> <p>9.5 10 3/8 19 30</p> <p>3/8</p>	<p>S01272-001</p> <p>11.1 11 7/16 19 30</p> <p>7/16</p>
<p>S01273-001</p> <p>12.7 13 1/2 19 30</p> <p>1/2</p>	<p>S03280-001</p> <p>14.3 14 9/16 19 30</p> <p>9/16</p>	<p>S01274-001</p> <p>15.9 16 5/8 19 30</p> <p>5/8</p>	<p>S01275-001</p> <p>19.1 19 3/4 19 30 6.5</p> <p>3/4</p>	<p>S01276-001</p> <p>22.2 22 7/8 19 30 6.5</p> <p>7/8</p>	<p>S35630-001</p> <p>25.4 25 1 19 28 4</p> <p>1</p>

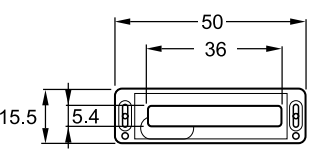
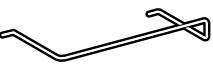
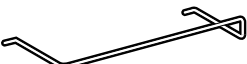
## Ga2 . ゲージ部品一覧表 / Gauge parts list

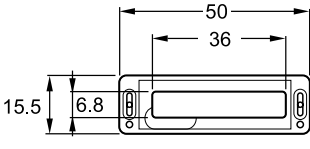
- ※ 1 布つかみ組 フィンガーガード付 / Work clamp assy, W/F-G
- ※ 2 フィンガーガード / Finger guard
- ※ 3 布つかみ / Work clamp

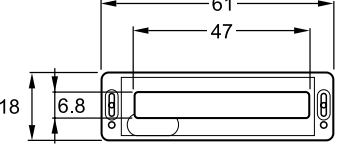
< -2用 / For -2 >		
※ 1 S37101-202 (16mmRS)	※ 1 S37100-302 (25mmRS)	※ 1 S55347-202 (25mmRSW)
※ 2 159079-100	※ 2 159080-100	※ 2 159080-100
※ 3 159761-002	※ 3 159762-002	※ 3 S55345-002
※ 2 	※ 2 	※ 2 
※ 3  	※ 3  	※ 3  
縫製エリア 4 X 20	縫製エリア 4 X 32	縫製エリア 6 X 32
< -2用 / For -2 >	< -3用 / For -3 >	
※ 1 S37109-202 (32mmRS)	※ 1 S37103-201 (16mm)	※ 1 S37102-301 (25mm)
※ 2 159081-100	※ 2 159079-100	※ 2 159080-100
※ 3 159763-002	※ 3 145136-001	※ 3 144630-001
※ 2 	※ 2 	※ 2 
※ 3  	※ 3  	※ 3  
縫製エリア 6 X 40	縫製エリア 4 X 20	縫製エリア 4 X 32
< -3用 / For -3 >		
※ 1 S55350-201 (25mmW)	※ 1 S37110-201 (32mm)	
※ 2 159080-100	※ 2 159081-100	
※ 3 S55348-001	※ 3 144632-001	
※ 2 	※ 2 	
※ 3  	※ 3  	
縫製エリア 5.4 X 32	縫製エリア 5.4 X 40	

Ga3 . ゲージ部品一覧表 / Gauge parts list







針板 / Needle plate

< -2用 / For -2 >		
S50663-001 (1.2mmS)	S50664-001 (1.4mmS)	S50665-001 (1.6mmS)
< -3用 / For -3 >		
S51248-101 (1.2mm)	S51249-101 (1.4mm)	S51250-101 (1.6mm)

平カッター用 / For flat cutter

< -2用 / For -2 >	
針板 / Needle plate S50321-001 (1.2mmS)	カッターウケ / Plastic plate 151843-001
< -3用 / For -3 >	
針板 / Needle plate S50322-101 (1.2mm)	カッターウケ / Plastic plate 156612-001

Wa. 警告ラベル / Warning labels

警告ラベル / Warning labels	品名 / Name of parts	Size(mm)	Code
	ラベル感電6ヶ国 Label, elec. shock 6 lang	50 X 118	J04115-001
	ラベル注意・和英 Label, caution Jpn / Eng	52 X 84	SA0792-001
	ラベル注意・中英 Label, caution Chn / Eng	52 X 84	SA0793-001
	ワーニングマーク Mark, injury	L=16 R=0.8	S36924-001
	PE マーク Label, PE	7.5 X 12.5	S37059-001
	アースマーク Label, grounding	φ 12	S37060-001

## 索引 / Index

CODE	REF.NO	Page	CODE	REF.NO	Page	CODE	REF.NO	Page	CODE	REF.NO	Page
002300603	M - 81	28	018502032	G - 48	14	032461606	Z2 - 53	62	062670712	Q - 11	36
	U - 33	50	021060106	Z1 - 34	60	037401415	Z1 - 6	60	062670812	U - 15	50
002401006	W - 12	54	021080202	H - 46	18	047200642	P - 20	34	062671212	F - 50	12
012400636	P - 4	34	021100206	W - 5	54	048030342	R - 5	38	062671612	R - 64	40
	P - 25	34	021100302	C - 19	6	048040342	P - 26	34	062680512	R - 19	38
012500536	G - 27	14	021300206	Q - 36	36		Q - 49	36		R - 66	40
013761410	B - 36	4	021500104	Z2 - 13	62	048060142	F - 52	12		Z3 - 28	64
014060632	G - 6	14		Z2 - 20	62	048060342	A - 14	2	062680612	A - 4	2
	G - 8	14	021500216	G - 49	14		F - 34	12		M - 13	26
014400432	N - 4	30	021500316	Q - 58	36		H - 36	18		M - 33	26
014680632	H - 32	18	021660102	Z2 - 35	62		N - 80	32		M - 62	26
	Q - 50	36	021660306	K - 5	22		P - 8	34		N - 18	30
014760632	A - 15	2	021670202	R - 65	40	048080342	R - 8	38		Q - 22	36
	A - 18	2	021680202	A - 17	2	048150142	C - 2	6	062680712	M - 30	26
	B - 16	4		Q - 20	36	048220242	C - 28	6	062680812	G - 24	14
	B - 22	4	021710202	B - 35	4	048300242	C - 20	6		G - 44	14
	B - 24	4	021910302	H - 18	18	060300612	D - 6	8		M - 8	26
	C - 9	6	025030136	N - 82	32	060630312	R - 37	38		Z2 - 39	62
	C - 29	6	025030232	Z2 - 34	62	060660416	G - 22	14	062681012	B - 38	4
	D - 9	8	025040132	R - 36	38	060670412	R - 38	38	062681412	S - 5	42
	D - 12	8		R - 41	38	060670512	F - 60	12	062710612	Z2 - 36	62
	D - 14	8	025040173	W - 11	54		N - 12	30	062710812	H - 48	18
	F - 10	12	025040232	F - 63	12		N - 74	32	062711012	A - 2	2
	F - 13	12	025050236	Z1 - 19	60		N - 76	32		A - 6	2
	F - 28	12	025060132	F - 51	12	060670612	J - 4	20	062711212	D - 3	8
	F - 35	12	025060232	C - 23	6		M - 15	26	062711412	H - 41	18
	F - 40	12		G - 3	14		M - 20	26	062711612	A - 8	2
	F - 55	12		J - 2	20		M - 64	28		D - 4	8
	G - 16	14	025060336	Z1 - 35	60		M - 76	28	062761012	G - 2	14
	H - 2	18	025080132	A - 13	2	062060804	Z2 - 3	62		H - 11	18
	H - 35	18		F - 33	12	062061604	Z2 - 21	62	070608800	C - 27	6
	J - 9	20		P - 7	34	062300502	N - 25	30	070688850	G - 11	14
	K - 3	22	025100236	W - 6	54	062300806	U - 9	50	072630260	C - 3	6
	L - 4	24	025350132	M - 5	26		U - 11	50	076002450	L - 3	24
	N - 5	30		M - 50	26		U - 13	50	076200800	C - 21	6
	N - 9	30		U - 16	50		U - 19	50	081005070	N - 7	30
	Q - 3	36		U - 24	50		U - 29	50	081007070	Z1 - 7	60
	R - 9	38	025350332	J - 3	20		V - 7	52	081012070	Q - 45	36
	R - 15	38	025680132	G - 25	14	062400612	J - 11	20	081014870	N - 69	32
014770632	B - 3	4		G - 42	14		J - 13	20	087310816	V - 2	52
	B - 15	4		Q - 21	36		M - 66	28	087311016	V - 6	52
	F - 4	12		Q - 55	36		M - 69	28	0A4400606	V - 3	52
	H - 28	18		Q - 62	36	062400616	P - 19	34	0A4401605	X - 2	56
	L - 7	24		S - 6	42	062400806	E - 2	10	0A5302005	U - 21	50
014780632	C - 7	6		Z3 - 35	64		S - 2	42	0A5400806	U - 31	50
	C - 13	6	025680232	Q - 23	36	062400812	Z3 - 21	64	0A5401006	U - 38	50
	H - 7	18		Q - 38	36		Z3 - 23	64		U - 40	50
	P - 28	34		Z3 - 29	64	062400816	P - 13	34		U - 42	50
018061032	F - 2	12	025680234	N - 19	30		P - 15	34		U - 44	50
018061036	Z2 - 52	62	026040236	P - 16	34	062401063	W - 9	54	100022005	B - 37	4
018061632	C - 22	6	028030246	Q - 35	36	062501404	Z2 - 22	62	100136001	Z3 - 19	64
	Q - 51	36	028040245	W - 10	54	062660412	Z3 - 14	64	100242003	F - 57	12
	Q - 63	36	028050242	F - 19	12	062670412	Z3 - 31	64	100250001	B - 2	4
018062032	D - 16	8	028050243	Q - 57	36	062670512	M - 11	26	100402004	N - 68	32
018102536	C - 18	6	028050244	Z2 - 12	62		M - 56	26	100644005	K - 8	22
018300636	N - 24	30	028080242	H - 45	18		M - 79	28		Q - 30	36
018300836	Q - 33	36	028080246	Z1 - 15	60	062670612	L - 13	24	100645003	N - 13	30
018400636	Z2 - 51	62	028100246	W - 7	54		M - 4	26		N - 17	30
018400832	F - 8	12	028680242	G - 36	14		M - 27	26	100666002	Z2 - 26	62
018401032	G - 4	14		Q - 39	36		M - 49	26	101118001	Z1 - 16	60
018401232	D - 5	8	031412506	Z2 - 54	62		N - 22	30	101572102	Z1 - 23	60
	F - 14	12	031452204	Z2 - 4	62		N - 35	30	101671002	J - 8	20
018501032	H - 42	18	032461606	Z2 - 30	62		U - 23	50		Z3 - 34	64



CODE	REF.NO	Page	CODE	REF.NO	Page	CODE	REF.NO	Page	CODE	REF.NO	Page
102538002	F -62	12	115188101	P -23	34	145446002	P -22	34	159379001	H -33	18
102630001	H -9	18	115503001	H -26	18	145465001	B -6	4		R -71	40
104449001	A -24	2	117143003	A -16	2	145472001	F -47	12		R -74	40
	A -29	2	117363001	F -22	12	145478101	F -31	12	159384009	Z1 -32	60
	A -30	2		F -26	12		F -36	12	159624001	B -19	4
	A -36	2	117466000	Z1 -25	60		F -39	12	159625001	D -20	8
	A -41	2	117936001	A -44	2		R -12	38	159761002	Ga2	66
	Z1 -18	60		Q -41	36	146000001	Z3 -30	64	159762002	G -52	14
104450101	A -10	2	118735001	D -15	8	146255000	Z1 -38	60		Ga2	66
	A -26	2	118837001	Z1 -22	60	146256001	Z1 -37	60	159763002	Ga2	66
	A -27	2	119101021	Z3 -45	64	148847001	Z2 -37	62	159805001	N -39	30
	A -28	2	119710021	Z3 -42	64	149127001	R -20	38		N -50	30
	A -31	2	119711021	Z3 -43	64		R -52	38		N -62	30
	A -32	2	120263001	A -43	2	150172003	Z2 -8	62	159917201	N -78	32
	A -33	2	122771051	Z3 -6	64		Z2 -19	62	159924001	R -63	38
	A -34	2		Z3 -9	64	150174000	Z2 -9	62	159926001	G -53	14
	A -35	2	123185001	R -51	38	150179002	Z2 -11	62		G -53	16
	Z2 -28	62	133740006	Z1 -33	60	150182000	Z2 -6	62	159927001	G -56	14
104451101	A -25	2	133792121	Z3 -48	64	150183000	Z2 -16	62		G -56	16
104521001	L -6	24		Z3 -41	64	150189109	Z2 -2	62	180721001	K -21	22
105130001	G -38	14	140004001	B -8	4	150382001	B -30	4	183507001	K -22	22
105161003	Q -15	36	140407001	F -46	12	150491101	R -14	38	183526001	K -17	22
	Z3 -32	64	140430001	B -10	4	150553003	N -33	30	183598001	K -19	22
105237002	R -70	40	140518001	Z1 -8	60	151148001	N -54	30	183827001	L -5	24
105288002	Z3 -4	64	140553102	B -27	4	151843001	Ga3	67	200190001	Z2 -31	62
105970001	R -53	38	141513001	Q -27	36	151927001	M -53	26	215082001	W -13	54
	Z3 -10	64	141514001	Q -28	36	152969001	U -32	50	217071001	X -5	56
106436001	M -51	26		R -40	38	153057102	H -24	18	218859001	U -35	50
106629002	R -57	38		R -50	38	153242000	Z2 -42	62	228475000	M -47	26
107093002	Q -37	36	141519001	R -3	38	153483001	B -34	4		M -74	28
107149001	M -52	26	141590001	N -32	30	154965001	B -32	4		U -6	50
107401001	G -54	14	141619001	J -6	20	155578000	F -58	12		U -34	50
107404001	G -55	14	141620001	J -7	20	156612001	Ga3	67	229017001	X -4	56
	G -55	16		Z3 -33	64	157968001	P -18	34		X -8	56
107407003	Z3 -24	64	142274101	L -11	24	158830001	A -19	2		X -10	56
107639001	R -62	38	142443001	Z1 -21	60	158831001	A -20	2	232384001	T1 -10	44
107744001	R -2	38	142990001	Z2 -17	62	158832000	A -21	2	552907000	M -3	26
108265009	P -24	34	143748001	Z3 -13	64	158879001	A -11	2		U -37	50
108494001	Z3 -17	64	143749001	Z3 -12	64	158888001	B -21	4	552908000	U -39	50
108495001	Z3 -18	64	143767102	Z3 -15	64	158893100	C -5	6		U -41	50
110027001	Q -2	36	143980001	Z3 -16	64	158945001	D -21	8	625010000	U -14	50
	Z3 -11	64	144075001	Q -14	36	158946001	D -22	8	J00107001	W -2	54
110161004	F -18	12	144103009	N -40	30	159078001	G -47	14	J00351001	X -9	56
	R -4	38		N -51	30	159079100	Ga2	66	J00353001	Z2 -44	62
110167001	R -47	38	144110101	N -41	30	159080100	G -46	14	J02036001	Z2 -45	62
110168001	R -48	38	144226001	Z2 -48	62		Ga2	66	J02293001	X -7	56
110215002	R -31	38	144628001	Z3 -8	64	159081100	Ga2	66	J02513001	X -1	56
	R -45	38	144630001	G -52	16	159104001	H -31	18	J02517001	W -3	54
110367001	B -4	4		Ga2	66	159113101	R -69	40	J02727001	T1 -7	44
	F -12	12	144632001	Ga2	66	159117001	H -12	18	J03275001	W -4	54
	H -37	18	144707001	G -54	16	159145001	J -5	20	J03410001	W -8	54
110494001	R -7	38	144872101	M -9	26	159150000	A -22	2	J03411001	Z2 -43	62
110735002	G -33	14	144874001	M -10	26		A -23	2	J03466001	T1 -4	44
111466121	F -41	12	144875001	M -1	26	159158051	K -23	22	J03763001	X -3	56
111865009	C -30	6	144997001	Z3 -5	64		Z1 -24	60	J03764001	X -6	56
112467002	M -6	26	144998001	Z3 -3	64	159187000	M -28	26	J04115001	T1 -45	44
112525000	Z2 -46	62	144999001	Z3 -7	64	159193000	M -36	26		Wa	68
112751003	N -79	32	145136001	Ga2	66	159221101	N -63	30	J80380040	Y -5	58
113316001	N -75	32	145371001	R -44	38	159224001	N -72	32	J803800E0	Y -5	58
113730001	R -22	38	145440001	N -48	30	159267001	R -6	38	J80814001	T1 -27	44
114483002	Z1 -31	60	145446001	N -38	30	159269001	R -16	38	J80863001	W -1	54
114859001	Z3 -51	64		N -49	30	159272001	R -23	38	S00306001	A -12	2
114988001	N -57	30		N -61	30	159343001	Q -19	36	S00480000	M -48	26

## 索引 / Index

CODE	REF.NO	Page	CODE	REF.NO	Page	CODE	REF.NO	Page	CODE	REF.NO	Page
S00480000	U - 22	50	S36120021	Z3 - 47	64	S50152001	B - 31	4	S50226001	K - 1	22
S00554000	T1 - 2	44	S36121021	Z3 - 50	64	S50153101	B - 33	4	S50230001	K - 7	22
S00617000	Z1 - 36	60	S36522001	Z3 - 36	64	S50154001	C - 1	6	S50231200	K - 10	22
S00712101	R - 29	38		Z3 - 39	64	S50156001	C - 6	6	S50232000	K - 9	22
S00901001	R - 25	38	S36924001	A - 38	2	S50157001	C - 8	6	S50233001	K - 13	22
S00903001	R - 24	38		Wa	68	S50159001	C - 10	6	S50236001	K - 18	22
S01271001	Ga1	65	S37059001	T1 - 43	44	S50160001	C - 11	6	S50240001	L - 1	24
S01272001	Ga1	65		Wa	68	S50161000	C - 14	6	S50243101	L - 8	24
S01273001	Ga1	65	S37060001	A - 39	2	S50163001	C - 15	6	S50244101	L - 9	24
S01274001	Ga1	65		T1 - 44	44	S50164001	C - 16	6	S50245001	L - 12	24
S01275001	Ga1	65		Wa	68	S50165001	C - 17	6	S50246001	R - 1	38
S01276001	Ga1	65	S37100302	G - 51	14	S50166001	C - 24	6	S50247101	R - 10	38
S01696001	R - 58	38		Ga2	66	S50167001	C - 25	6	S50248101	R - 13	38
S01700001	Z2 - 33	62	S37101202	Ga2	66	S50168001	C - 26	6	S50249201	R - 17	38
S01998001	R - 60	38	S37102301	G - 51	16	S50169001	D - 1	8	S50252001	R - 21	38
S02460001	G - 20	14		Ga2	66	S50171001	D - 8	8	S50253001	R - 27	38
S02563001	Q - 16	36	S37103201	Ga2	66	S50172001	D - 10	8	S50257001	R - 28	38
	Q - 17	36	S37109202	Ga2	66	S50174001	D - 13	8	S50258201	R - 30	38
S02761509	Z2 - 1	62	S37110201	Ga2	66	S50176001	D - 18	8	S50259101	R - 32	38
S03280001	Ga1	65	S37111001	Z2 - 32	62	S50178001	D - 19	8	S50260101	R - 33	38
S06139001	Z3 - 26	64	S37927000	F - 56	12	S50179001	D - 23	8	S50263001	R - 34	38
S06140001	Z3 - 27	64	S37940001	D - 2	8	S50182000	E - 1	10	S50264000	R - 35	38
S07478000	K - 11	22	S38082001	S - 4	42	S50183001	F - 1	12	S50265001	R - 39	38
S08030000	T1 - 12	44	S38145000	U - 43	50	S50184001	F - 5	12	S50269000	R - 42	38
	Z2 - 41	62	S38146000	T1 - 29	44	S50185001	F - 7	12	S50270000	R - 43	38
S09212001	H - 27	18	S38155000	T1 - 17	44	S50186001	F - 9	12	S50271000	B - 11	4
S09477001	K - 20	22		T3 - 3	48	S50187001	F - 11	12	S50272000	B - 12	4
S10174000	P - 17	34	S38200000	T1 - 9	44	S50189001	F - 15	12	S50273000	J - 1	20
S10243000	U - 30	50		T3 - 4	48	S50190001	F - 16	12	S50274001	J - 10	20
S12004000	G - 19	14	S38201000	T1 - 5	44	S50191001	F - 17	12	S50275001	J - 12	20
	G - 34	14		T1 - 11	44	S50192101	F - 20	12	S50276001	P - 1	34
S13595201	Z1 - 40	60	S38735001	L - 10	24		F - 24	12	S50278001	P - 2	34
S13596201	Z1 - 40	60	S38736301	P - 21	34	S50193001	F - 27	12	S50279101	P - 6	34
S18707153	Z1 - 20	60	S38761201	F - 23	12	S50195001	F - 29	12	S50280001	P - 12	34
S19817001	Q - 6	36		F - 30	12	S50196001	F - 32	12	S50281000	P - 27	34
S23337001	Q - 4	36	S40620000	T1 - 40	44	S50198001	F - 37	12	S50282000	P - 29	34
S24250001	Z1 - 13	60	S41216000	U - 45	50	S50199101	F - 38	12	S50283001	H - 1	18
S25328001	M - 57	26	S42116000	F - 6	12	S50200001	F - 43	12	S50284101	H - 3	18
	M - 84	28	S43717201	F - 3	12	S50201001	F - 48	12	S50285101	H - 4	18
S25410050	P - 3	34	S46455000	T3 - 2	48	S50202001	F - 49	12	S50286101	H - 5	18
S25413101	P - 9	34	S47668000	T3 - 5	48	S50203101	F - 53	12	S50287001	H - 6	18
S25417001	P - 10	34	S47680000	T3 - 6	48	S50204001	F - 54	12	S50288001	H - 8	18
S25418101	P - 11	34	S47721301	T1 - 3	44	S50205001	F - 59	12	S50289001	H - 13	18
S25420051	P - 14	34	S47750000	Y - 6	58	S50206001	F - 61	12	S50290001	H - 14	18
S25456001	N - 27	30	S48034001	C - 12	6	S50207001	G - 1	14	S50291001	H - 15	18
S25642001	Ga1	65	S49486000	T1 - 19	44	S50208001	G - 5	14	S50292001	H - 16	18
S25789000	P - 5	34	S50110001	G - 7	14	S50209000	G - 9	14	S50293001	H - 17	18
S30564000	N - 42	30	S50111100	K - 14	22	S50210001	G - 10	14	S50294001	H - 19	18
	N - 64	32	S50113101	Q - 26	36	S50211101	G - 12	14	S50295001	H - 21	18
S30565003	N - 43	30	S50124001	A - 1	2	S50212001	G - 14	14	S50296001	H - 23	18
S30565005	N - 55	30	S50126001	A - 5	2	S50213001	G - 15	14	S50297001	H - 50	18
S31012001	F - 45	12	S50127101	A - 7	2	S50214001	G - 17	14		Y - 3	58
S31013001	F - 44	12	S50128201	A - 9	2	S50215101	G - 23	14	S50298101	H - 29	18
S31032001	N - 65	32	S50131001	A - 40	2	S50216101	G - 26	14	S50299101	H - 30	18
S31808001	B - 29	4	S50132000	B - 1	4	S50217001	G - 28	14	S50300001	H - 34	18
S32263001	A - 37	2	S50136101	B - 7	4	S50218001	G - 29	14	S50303101	R - 55	38
S32521001	D - 17	8	S50142000	B - 13	4	S50219101	G - 30	14	S50304001	Y - 2	58
S35095000	N - 3	30	S50143001	B - 17	4	S50220001	G - 50	14	S50309001	Y - 2	58
S35184001	G - 21	14	S50144001	B - 18	4	S50221101	G - 37	14	S50311001	Y - 2	58
S35630001	Ga1	65	S50146001	B - 20	4	S50222001	G - 39	14	S50313101	Y - 2	58
S36114021	Z3 - 46	64	S50147001	B - 23	4	S50223100	G - 40	14	S50317101	Y - 2	58
S36119021	Z3 - 44	64	S50149101	B - 26	4	S50224001	G - 43	14	S50319101	Y - 2	58
	Z3 - 49	64	S50150001	B - 28	4	S50225001	G - 50	16	S50321001	Ga3	67

CODE	REF.NO	Page	CODE	REF.NO	Page	CODE	REF.NO	Page	CODE	REF.NO	Page
S50322101	Ga3	67	S50395201	Q - 7	36	S50530000	M - 44	26	S51359001	Ga1	65
S50323000	R - 59	38	S50398001	Q - 8	36	S50531000	M - 45	26	S51360001	Ga1	65
S50324001	R - 61	38	S50399101	Q - 9	36	S50532000	M - 46	26	S51361001	Y - 1	58
S50325001	R - 67	40	S50400001	Q - 10	36	S50533000	M - 54	26	S51362001	Y - 1	58
S50326001	R - 68	40	S50401001	Q - 12	36	S50536001	M - 55	26	S51363001	Y - 1	58
S50327001	R - 72	40	S50403101	Q - 18	36	S50537000	M - 58	26	S51364001	Y - 1	58
S50328001	R - 73	40	S50404401	Q - 24	36		M - 72	28	S51365001	Y - 1	58
S50329000	R - 75	40	S50405301	Q - 25	36	S50538001	M - 59	26	S51366001	Y - 1	58
S50330101	Z1 - 1	60	S50410101	Q - 40	36	S50539000	M - 60	26	S51896001	Z3 - 2	64
S50331000	Z1 - 2	60	S50411101	Q - 42	36	S50540001	M - 61	26	S52248001	B - 14	4
S50332000	Z1 - 3	60		R - 11	38	S50541001	M - 63	26	S52431000	Q - 29	36
S50334000	Z1 - 5	60	S50412000	Q - 43	36	S50542001	M - 65	28	S52433001	R - 46	38
S50335000	Z1 - 9	60	S50413101	Q - 44	36	S50543001	M - 67	28	S52434001	R - 49	38
S50336000	Z1 - 10	60	S50414001	Q - 46	36	S50544000	M - 68	28	S52761101	Q - 5	36
S50337000	Z1 - 11	60	S50415001	Q - 47	36	S50545000	M - 70	28	S52763000	M - 38	26
S50338000	Z1 - 12	60	S50416001	Q - 48	36	S50546000	M - 71	28	S52764001	M - 2	26
S50339001	Z1 - 17	60	S50425101	T1 - 8	44	S50547000	M - 73	28	S52770000	R - 56	38
S50340000	A - 42	2	S50431101	T1 - 14	44	S50548001	M - 75	28	S52778101	R - 54	38
S50341001	Y - 4	58	S50437000	T1 - 20	44	S50549000	M - 77	28	S52943101	B - 9	4
S50342000	Z1 - 14	60	S50438000	T1 - 21	44	S50550001	M - 78	28	S53902301	T3 - 1	48
S50344001	Z2 - 29	62	S50439000	T1 - 22	44	S50551001	M - 80	28	S54741001	K - 12	22
S50345001	Z2 - 38	62	S50441000	T1 - 24	44	S50552000	M - 82	28	S54767000	Z2 - 47	62
S50346001	Z3 - 1	64	S50442001	T2 - 1	46	S50556000	M - 16	26	S54768001	Z1 - 4	60
S50348001	Z3 - 20	64		T2 - 7	46	S50557000	M - 21	26	S55345002	Ga2	66
S50349001	Z3 - 22	64	S50444001	T2 - 2	46	S50558000	M - 22	26	S55347202	Ga2	66
S50350001	Z3 - 37	64	S50446001	T2 - 3	46	S50559001	M - 19	26	S55348001	Ga2	66
S50351001	Z3 - 40	64	S50447001	T2 - 6	46	S50562101	G - 45	14	S55350201	Ga2	66
S50354000	S - 3	42	S50453100	V - 4	52	S50563000	M - 17	26	S55361200	Z3 - 52	64
S50356001	M - 7	26	S50457000	V - 5	52	S50565001	U - 36	50	S55663001	Z1 - 30	60
S50359001	M - 12	26	S50458100	U - 1	50	S50644000	U - 46	50	S55975001	N - 71	32
S50360001	M - 14	26	S50459100	U - 2	50	S50644001	T1 - 26	44	S56391001	K - 4	22
S50362001	H - 40	18	S50460000	U - 3	50	S50645000	T1 - 18	44	S59890001	G - 13	14
S50363000	H - 43	18	S50461000	U - 4	50	S50657001	S - 1	42		G - 41	14
S50364001	H - 44	18	S50462000	U - 5	50	S50663001	Ga3	67	S59891001	H - 22	18
S50365101	H - 47	18	S50463000	U - 7	50	S50664001	R - 76	40	S59892001	G - 32	14
S50366001	H - 49	18	S50464000	U - 8	50		Ga3	67	S59893001	G - 31	14
S50368001	N - 1	30		U - 12	50	S50665001	Ga3	67		G - 35	14
S50369001	N - 2	30	S50465000	U - 10	50	S51020000	M - 83	28		H - 20	18
S50370001	N - 6	30	S50466000	U - 17	50	S51117001	Ga1	65		Q - 54	36
S50371101	N - 8	30	S50467000	U - 18	50	S51182501	N - 59	30		Q - 61	36
S50372101	N - 10	30	S50468000	U - 20	50	S51183101	N - 47	30	S59894001	G - 18	14
S50373101	N - 11	30	S50472000	U - 27	50	S51184201	N - 36	30		H - 39	18
S50374001	N - 14	30	S50473000	U - 28	50	S51190001	D - 11	8	S59987101	R - 18	38
S50375001	N - 15	30	S50476001	Z3 - 38	64	S51248101	R - 76	40	SA0287000	U - 47	50
S50376101	N - 16	30	S50477001	Z3 - 25	64		Ga3	67	SA0792001	A - 46	2
	N - 31	30	S50484000	T1 - 25	44	S51249101	Ga3	67		Wa	68
S50377001	N - 21	30	S50498001	T1 - 39	44	S51250101	Ga3	67	SA0793001	A - 45	2
S50378001	N - 23	30	S50511101	Q - 59	36	S51282101	Z2 - 7	62		Wa	68
S50380000	N - 28	30	S50513100	M - 23	26	S51283001	Z2 - 5	62	SA0990001	N - 29	30
S50382001	N - 30	30	S50514000	M - 24	26	S51290001	Z1 - 26	60	SA0992001	N - 26	30
S50383001	N - 34	30	S50515000	M - 25	26		Ga1	65	SA2385001	H - 10	18
S50384101	N - 45	30	S50516001	M - 26	26	S51351001	Ga1	65	SA2412001	H - 38	18
	N - 70	32	S50517001	M - 29	26	S51352001	H - 25	18	SA2823001	T1 - 13	44
S50385001	N - 46	30	S50518000	M - 31	26		Ga1	65	SA2870001	T1 - 6	44
S50386101	N - 52	30	S50519000	M - 32	26	S51353001	Ga1	65		Z2 - 40	62
S50387001	N - 53	30	S50520000	M - 34	26	S51354001	Z1 - 27	60	SA2881001	D - 7	8
S50388001	N - 56	30	S50521000	M - 35	26		Ga1	65	SA2921101	B - 25	4
S50389001	N - 58	30	S50522000	M - 37	26	S51355001	Ga1	65	SA3001001	F - 21	12
S50390101	N - 67	32	S50524000	M - 39	26	S51356001	Z1 - 29	60		F - 25	12
S50391001	N - 60	30	S50525000	M - 40	26		Ga1	65		R - 26	38
S50392001	N - 73	32	S50527000	M - 41	26	S51357001	Ga1	65	SA3025001	Z2 - 27	62
S50393000	N - 77	32	S50528000	M - 42	26	S51358001	Z1 - 28	60	SA3033001	L - 2	24
S50394001	Q - 1	36	S50529000	M - 43	26		Ga1	65	SA3035001	N - 81	32

索引 / Index

CODE	REF.NO	Page	CODE	REF.NO	Page	CODE	REF.NO	Page	CODE	REF.NO	Page
SA3079001	T1 -28	44									
SA3081001	V -1	52									
SA3101001	T1 -28	44									
SA3113001	U -25	50									
SA3176101	T1 -38	44									
SA3189001	T1 -30	44									
SA3190001	T1 -37	44									
SA3191001	T1 -36	44									
SA3192001	T1 -35	44									
SA3193001	T1 -34	44									
SA3194001	T1 -41	44									
SA3195001	T1 -32	44									
SA3196001	T1 -31	44									
SA3797001	T1 -42	44									
SA3921001	T1 -33	44									
SA3966001	T2 -4	46									
SA3967001	T2 -5	46									
SA3969001	T2 -9	46									
SA4020001	T2 -8	46									
SA4024001	T1 -1	44									
SA4047301	B -5	4									
SA4063001	M -18	26									
SA4065001	C -4	6									
SA4066001	M -85	28									
SA4067001	M -86	28									
SA4206001	A -3	2									
SA4232001	N -37	30									
SA4233001	N -44	30									
SA6113001	N -20	30									
SA6302001	T1 -15	44									
SA6303001	T1 -16	44									
SA6606001	Z2 -10	62									
SA6607001	Z2 -14	62									
	Z2 -15	62									
SA6609001	Z2 -18	62									
SA7402001	K -6	22									
SA7405001	K -2	22									
SA7488001	U -26	50									
SA7607001	F -42	12									
SA8126001	K -16	22									
SA8391001	T1 -23	44									
SA8886001	T1 -46	44									
SA9058001	N -66	32									
SA9138001	K -15	22									
SA9140001	K -24	22									
SA9141001	K -25	22									
SA9157001	Z2 -23	62									
SA9158001	Z2 -24	62									
SA9159001	Z2 -25	62									
SA9160001	Z2 -49	62									
SA9161001	Z2 -50	62									
SA9165001	Q -13	36									
SA9166001	Q -31	36									
SA9167001	Q -32	36									
SA9168001	Q -34	36									
SA9169001	Q -52	36									
SA9170001	Q -53	36									
SA9171001	Q -60	36									
SA9172001	Q -56	36									
SA9254011	Z1 -39	60									
SA9254014	Z1 -39	60									

# MEMO

# MEMO

# MEMO

brother®

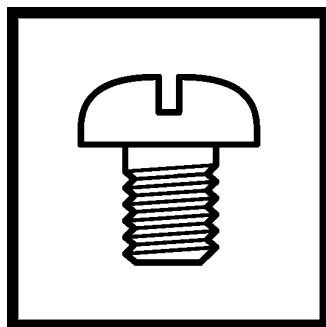

パーツブック  
PARTS BOOK

**ブラザー工業株式会社** <http://www.brother.co.jp/>

〒467-8561 名古屋市瑞穂区苗代町 15 番 1 号 TEL : 0120-33-2392

**BROTHER INDUSTRIES, LTD.** <http://www.brother.com/>

15-1, Naeshiro-cho, Mizuho-ku, Nagoya 467-8561, Japan. Phone : 81-52-824-2177



SA9164001  
零件手册

HE-800A  
SA9164-001  
2007.11.B (1)