

杰克缝纫机
全球销量遥遥领先
Leading in global sales

400-8876-858
www.chinajack.com



JACK SEWING MACHINE CO.,LTD.

2017年7月份 Edition: July , 2017

杰克缝纫机股份有限公司

中国浙江省台州市椒江区三甲东海大道东段1008号
电话 :0086-576-88177788 88177789

JACK SEWING MACHINE CO.,LTD.

NO.1008 , DONGHAI AVENUE EAST , JIAOJIANG DISTRICT,TAIZHOU CITY , ZHEJIANG
TEL: 0086-576-88177782 88177767 E-mail: sales@chinajack.com

目 录

1. 各部件名称	1
2. 缝纫机规格.....	1
3. 台板.....	2
4. 安装方法.....	3
4-1. 安装机头.....	3
4-2. 线团架.....	4
4-3. 润滑油.....	5
4-4. 检查运转方向.....	6
5. 缝纫前的准备.....	6
5-1. 机针和线.....	6
5-2. 机针的安装方法.....	7
5-3. 下线的穿法.....	7
5-4. 上线的穿法.....	8
6. 缝纫.....	8
7. 缝纫效果.....	9
7-1. 调节线张力.....	9
7-2. 调节压脚压力.....	10
7-3. 调节针距.....	10
7-4. 调节滑轮.....	11
8. 保养.....	12
8-1. 清洗.....	13
8-2. 更换润滑油.....	13
9. 标准调节.....	14
9-1. 针杆高度的调节.....	14
9-2. 弯针和针的调整.....	15
9-3. 调整弯针勾线.....	16
9-4. 调整护针架.....	17
9-5. 送料牙的高度调节.....	18
9-6. 上过线的调节.....	18
9-7. 上线引导器的调节.....	19
9-8. 松线杆的调节.....	19
9-9. 底线绕线器的调节.....	19
9-10. 引导板的安装.....	20
9-11. 滑轮的调节.....	20
9-12. 调速器的调节.....	20
10. 故障检修.....	21

CONTENTS

1. NAMES OF MAJOR PARTS.....	1
2. MACHINE SPECIFICATIONS.....	1
3. WORK TABLE.....	2
4. INSTALLATION.....	3
4-1. Installing the machine head.....	3
4-2. Cotton stand.....	4
4-3. Lubrication.....	5
4-4. Checking the machine pulley rotation direction.....	6
5. PREPARATION BEFORE SEWING.....	6
5-1. Needle and threads.....	6
5-2. Installing the needles.....	7
5-3. Threading the lower threads.....	7
5-4. Threading the upper threads.....	8
6. SEWING.....	8
7. THREAD TENSION.....	9
7-1. Adjusting the thread tension.....	9
7-2. Presser foot pressure adjustment.....	10
7-3. Adjusting the stitch length.....	10
7-4. Puller feed adjustment (Machines with puller).....	11
8. CLEANING.....	12
8-1. Daily cleaning.....	13
8-2. Changing the lubricating oil (every three months).....	13
9. STANDARD ADJUSTMENTS.....	14
9-1. Needle bar height adjustment.....	14
9-2. Needle and looper timing adjustment.....	15
9-3. Timing of loopers running clear of needles.....	16
9-4. Needle guard adjustment.....	17
9-5. Feed dog height adjustment.....	18
9-6. Upper thread take-up thread guide adjustment.....	18
9-7. Upper thread arm thread guide adjustment.....	19
9-8. Thread release shaft adjustmen.....	19
9-9. Lower thread take-up timing adjustment.....	19
9-10. Installing the lapper.....	20
9-11. Puller height adjustment (Machine with puller).....	20
9-12. Puller device timing adjustment (Machines with puller).....	20
10. TROUBLE SHOOTING.....	21

十分感谢您购买我司工业缝纫机
在使用缝纫机之前，请仔细阅读<为了您的安全使用>和使用说明书。

工业缝纫机的特性之一，因为要在机针和弯针等运动另部件附近进行操作，而这些另部件很容易引起受伤的危险，所以请在受过培训的人或熟练人员的安全操作知识的指导下，正确地使用本缝纫机。



为了您的安全使用

1. 安全使用的标记及其意义

本使用说明书及产品所使用的标记和图案记号是为了您的安全而正确地使用产品，防止您及其他人受到危害和损害。

表示方法及含意如下：

标 记

	危 险 如果忽视此标记而进行了错误的操作，肯定会引起人员死亡或重伤。
	注 意 如果忽视此标记而进行了错误的操作，有可能会引起人员受伤及造成设备损坏。

图案和符号



· · · · 该符号表示"应该注意事项"。
三角中的图案表示必须要注意的实质内容。
(例如，左边的图案表示"当心受伤")



· · · · 该符号表示"禁止"。









· · · · 该符号表示"必须"。
圆圈中的图案表示必须要做的事情的实质内容。
(例如，左边的图案表示"必须接地")











2. 安全注意事项

注意

使用环境











-  应避免在强电气干扰源(如高频焊机)的附近使用本缝纫机。
强电气干扰源可能会影响缝纫机的正确操作。
-  电源电压的波动应该在额定电压的±10%以内的环境下使用。
电压大幅度的波动会影响缝纫机的正确操作。
-  电源容量应大于缝纫机的消耗电量。电源容量不足会影响缝纫机的正确操作。
-  环境温度应在5°C~35°C的范围内使用。低温或高温会影响缝纫机的正确操作。
-  相对温度应在45%~85%的范围内，并且设备内不会形成结露的环境下使用。
干燥或多湿的环境和结露会影响缝纫机的正确操作。
-  使用时应避免暴露于直射的阳光下。
直射的阳光下会影响缝纫机的正确操作。
-  万一发生雷电暴风雨时，关闭电源开关，并将电源插头从插座上拔下。雷电可能会影响缝纫机的正确操作。

安 装





-  请让受过培训的技术人员来安装缝纫机。
-  请委托购买商店或电气专业人员进行电气配线。
-  缝纫机重56公斤，安装工作必须由两人以上来完成。
-  在安装完成前，请不要连接电源，如果误按起动开关，缝纫机动作会导致受伤。
-  请在切断电源后，再拔掉电插头。
不然易成为控制箱发生故障的原因。
-  必须接地。
接驳地线不牢固，是造成触电或误动作的原因。
-  固定电缆时，不要过度弯曲电缆或用卡钉固定得过紧，会引起火灾或触电的危险。
-  如果使用带小脚轮的工作台，则应该固定小脚轮，使其不能移动。
-  缝纫机头倒下或竖起时，请用双手进行操作。单手操作时因缝纫机的重量万一滑落易导致受伤。
-  使用润滑油和黄油时，务必戴好护眼镜和保护手套等，以防润滑油落入眼中或沾在皮肤上，这是引起发炎的原因。
另外，润滑油或黄油不能饮用，否则会引起呕吐和腹泻。
将油放在小孩拿不到的地方。

注意

缝 纫

-  本缝纫机仅限于接受过安全操作培训的人员使用。
-  本缝纫机不能用于除缝纫外的任何其他用途。
-  使用缝纫机时必须戴上保护眼镜。如果不戴保护眼镜，断针时就会有危险，机针的折断部分可能会弹入眼睛并造成伤害。
-  发生下列情况时，请切断电源。否则误按动起动开关，缝纫机动作会导致受伤。
 - 机针穿线时
 - 更换机针或梭芯时
 - 缝纫机不使用，或人离开缝纫机时。
-  如果使用带小脚轮的工作台，则应该固定小脚轮使其不能移动。
-  为了安全起见，在使用本缝纫机之前，请安装保护装置。如果未安装这些安全装置就使用缝纫机，会造成人身伤害及缝纫机损坏。
-  缝纫过程中，不要触摸任何运动部件或将物件靠在运动部件上，因为这会导致人员受伤或缝纫机损坏。
-  缝纫机头倒下或竖起时，请用双手进行操作。单手操作时因缝纫机的重量万一滑落易导致受伤。
-  如果缝纫机操作中发生误动作，或听到异常的噪音或闻到异常的气味，应立即切断电。然后请与购买商店或受过培训的技术人员联系。
-  如果缝纫机出现故障，请与购买商店或受过培训的技术人员联系。

清 洁

-  在开始清洁作业前，请切断电源。如果当误按动起动开关时，缝纫机动作会导致人员受伤。
-  缝纫机头倒下或竖起时，请用双手进行操作。单手操作时因缝纫机的重量万一滑落易导致受伤。
-  使用润滑油和黄油时，务必戴好保护眼镜和保护手套等，以防润滑油落入眼中或沾在皮肤上，这是引起发炎的原因。另处，润滑油或黄油不能饮用，否则会引起呕吐和腹泻。将油放在小孩拿不到的地方。
-  请使用我司指定更换的零部件。

Thank you very much for buying sewing machine. Before using your new machine, please read the safety instructions below and the explanations given in the instruction manual.

With industrial sewing machines, it is normal to carry out work while positioned directly in front of moving parts such as the needle and thread take-up and thread take-up lever, and consequently there is always a danger of injury that can be caused by these parts. Follow the instructions from training personnel and instructors regarding safe and correct operation before operating the machine so that you will know how to use it correctly.

SAFETY INSTRUCTIONS

1. Safety instruction and their meaning

This instruction manual and the indications and symbols that are used on the machine itself are provided in order to ensure safe operation of this machine and to prevent accidents and injury to yourself or other people.

The meanings of these indications and symbols and symbols are given below.

Indications

 CAUTION	The instructions which follow this term indicate situations where failure to follow the instructions could cause injury when using the machine or physical damage to equipment and surroundings.
----------------------------------------------------------------------------------------------------	--------------------------------------------------------------------------------------------------------------------------------------------------------------------------------------------------

Symbols



- • • • This symbol indicates something that you should be careful of. The picture inside the triangle indicates the nature of the caution that must be taken.
(For example, the symbol at left means "beware of injury".)



- • • • This symbol indicates something that you must not do.









- • • • This symbol indicates something that you must do. The picture inside the circle indicates the nature of the thing that must be done.
(For example, the symbol at left means "you must make the ground connection".)





CAUTION







Sewing

-  This sewing machine should only be used by operators who have received the necessary training in safe use before-hand.
-  The sewing machine should not be used for any applications other than sewing.
-  Attach all safety devices before using the sewing machine. If the machine is used without these devices attached, injury may result.
-  Do not touch any of the moving parts or press any objects against the machine while sewing, as this may result in personal injury or damage to the machine.
-  Turn off the power switch at the following times, the machine may operate if the treadle is pressed by mistake, which could result in injury.
 - When threading the needle
 - When replacing the needle
 - When not using the machine and
 - When leaving the machine unattended
-  If using a work table which has casters, the casters should be secured in such a way so that they cannot move.
-  If an error occurs in machine, or if abnormal noises or smells are noticed, immediately turn off the power switch. Then contact your nearest Brother dealer or a qualified technician.

Cleaning

-  Turn off the power switch before carrying out cleaning. The motor will keep turning even after the power is switched off as a result of the motor's inertia. Wait until the motor stops fully before starting work.
The machine may operate if the treadle is pressed by mistake, which could result in injury.
-  Be sure to wear protective goggles and gloves when handling the lubricating oil, so that no oil gets into your eyes or onto your skin, otherwise inflammation can result.
Furthermore, do not drink the oil under any circumstances, as it can cause vomiting and diarrhoea.
Keep the oil out of the reach of children.

Maintenance and inspection

- Maintenance and inspection of the sewing machine should only be carried out by a qualified technician.
-  Ask your dealer or a qualified electrician to carry out any maintenance and inspection of the electrical system.
Turn off the power switch and disconnect the power cord from the wall outlet at the following times, otherwise the machine may operate if the treadle is pressed by mistake, which could result in injury.
-  However, the motor will keep turning even after the power is switched off as a result of the motor's inertia. Wait until the motor stops fully before starting work.
When carrying out inspection, adjustment and maintenance.
When replacing consumable parts such as the looper
-  If the power switch needs to be left on when carrying out some adjustment, be extremely careful to observe all safety precautions.
-  Use only the proper replacement parts as specified by our company.
-  If any safety devices have been removed be absolutely sure to re-install them to their original positions and check that they operate correctly before using the machine.
-  Any problems in machine operation which result from unauthorized modifications to the machine will not be covered by the warranty.

警告标签 / WARNING LABELS

缝纫机上有下列警告标签。

当使用缝纫机时，请遵守标签上的说明。如果标签脱落或模糊不清，请和经销商联系。

The following warning labels appear on the sewing machine.

Please following the instions on the labels at all times when using the machine. If the labels have been removed or are difficult to read, please contact your nearest dealer.

(1)



(2)



必须接地!

接驳地线不牢固，是造成触电或误动作的原因。

Be sure to connect the ground. If the ground connection is not secure, you run the risk of receiving a serious electric shock.

(3)



表示转动方向。

Direction of operation.

① 护指器 Finger guard

② 防护罩 Thread take-up cover

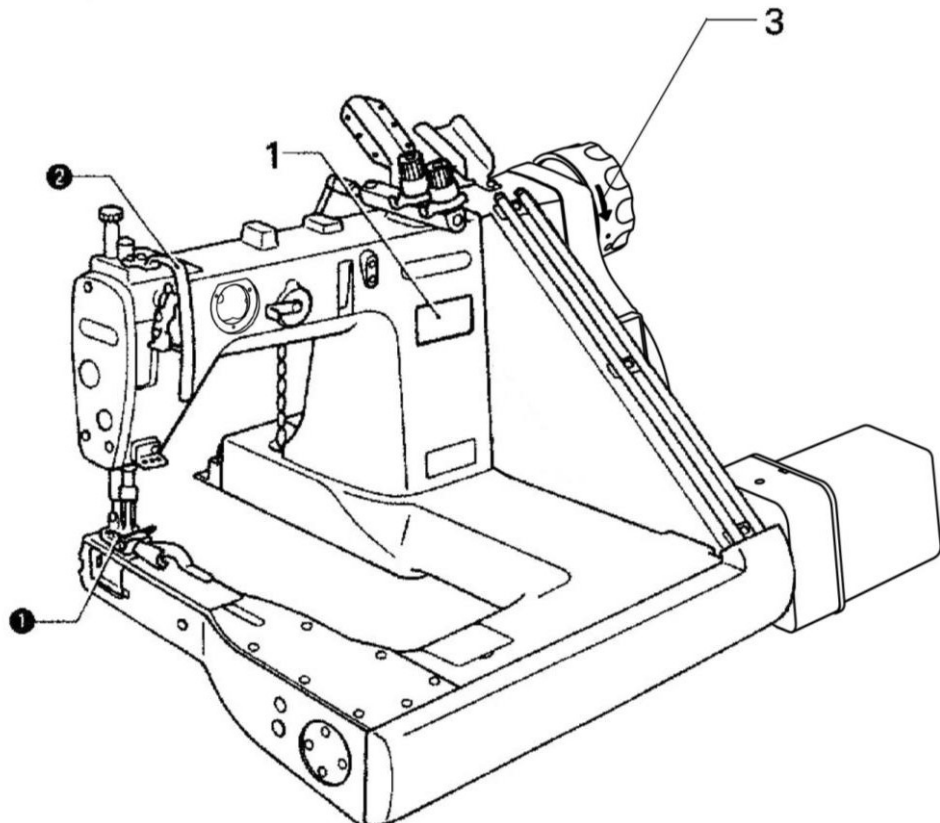

1. 各部件名称 / NAMES OF MAJOR PARTS

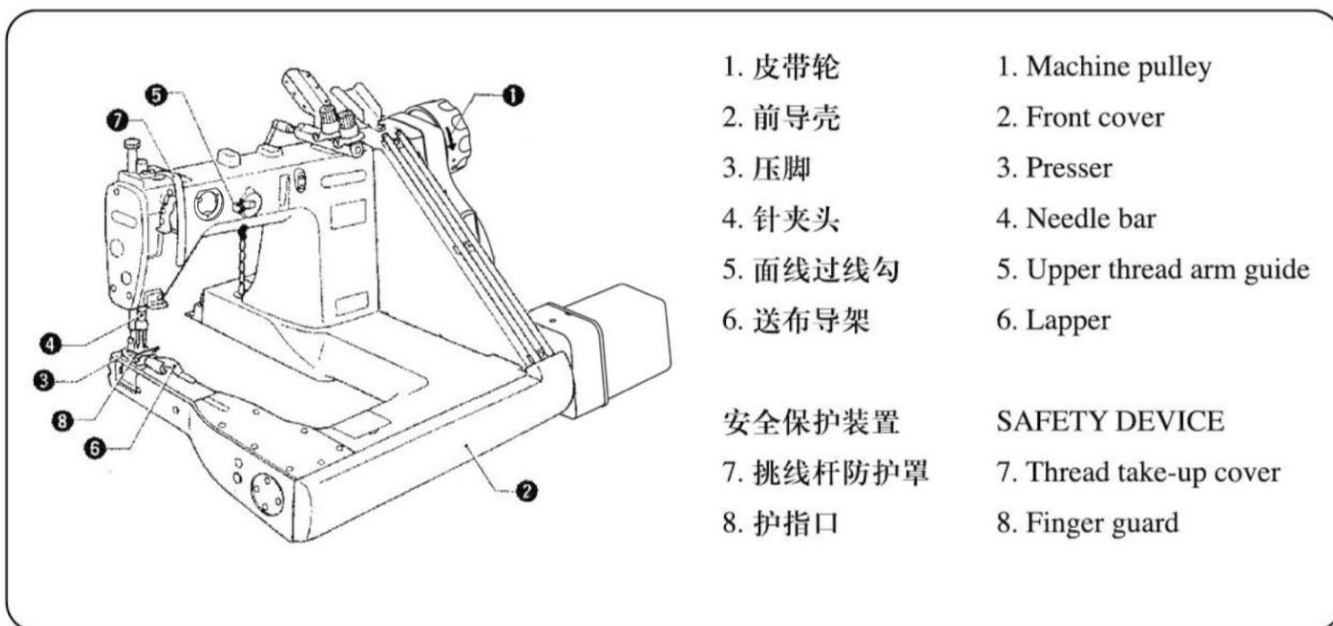

- | | |
|----------------------|---------------------------|
| 1. 皮带轮 | 1. Machine pulley |
| 2. 前导壳 | 2. Front cover |
| 3. 压脚 | 3. Presser |
| 4. 针夹头 | 4. Needle bar |
| 5. 面线过线勾 | 5. Upper thread arm guide |
| 6. 送布导架 | 6. Lapper |
| 安全保护装置 SAFETY DEVICE | |
| 7. 挑线杆防护罩 | 7. Thread take-up cover |
| 8. 护指口 | 8. Finger guard |

2. 缝纫机规格 / MACHINE SPECIFICATIONS



规格 Specifications	-1	-2	-5	-7
用途 Applications	薄料 Light materials	中厚面料 Light-medium materials	厚料 Thick material	极厚料 Very thick material
针数 NO. of needles	2, 3	2	3	3
机针型号 Type of needle	TV×64 12#	TV×64 14#	TV×5 21#	TV×5 21#
针距 Needle gauge	3.2mm (1/8) 4.8mm (3/16) 6.4mm (1/4)	4.8mm (3/16) 6.4mm (1/4)	3.2mm (1/8)	3.2mm (1/8)
最大线迹长度 Max. stitch length	3.5mm		4.2mm	
最小悬臂长度 Min. arm size	171mm			
最大缝纫速度 Max. sewing speed	4,000 rpm		3,600 rpm	

3. 工作台板 / WORK TABLE

台板的厚度应达40mm能够承受缝纫机的重量，并经得起缝纫机的震动。

请在如图指示位置钻孔。

The top of the table should be 40mm in thickness and should be strong enough to hold the weight and withstand the vibration of the sewing machine.

Drill holes as indicated in the illustration below.

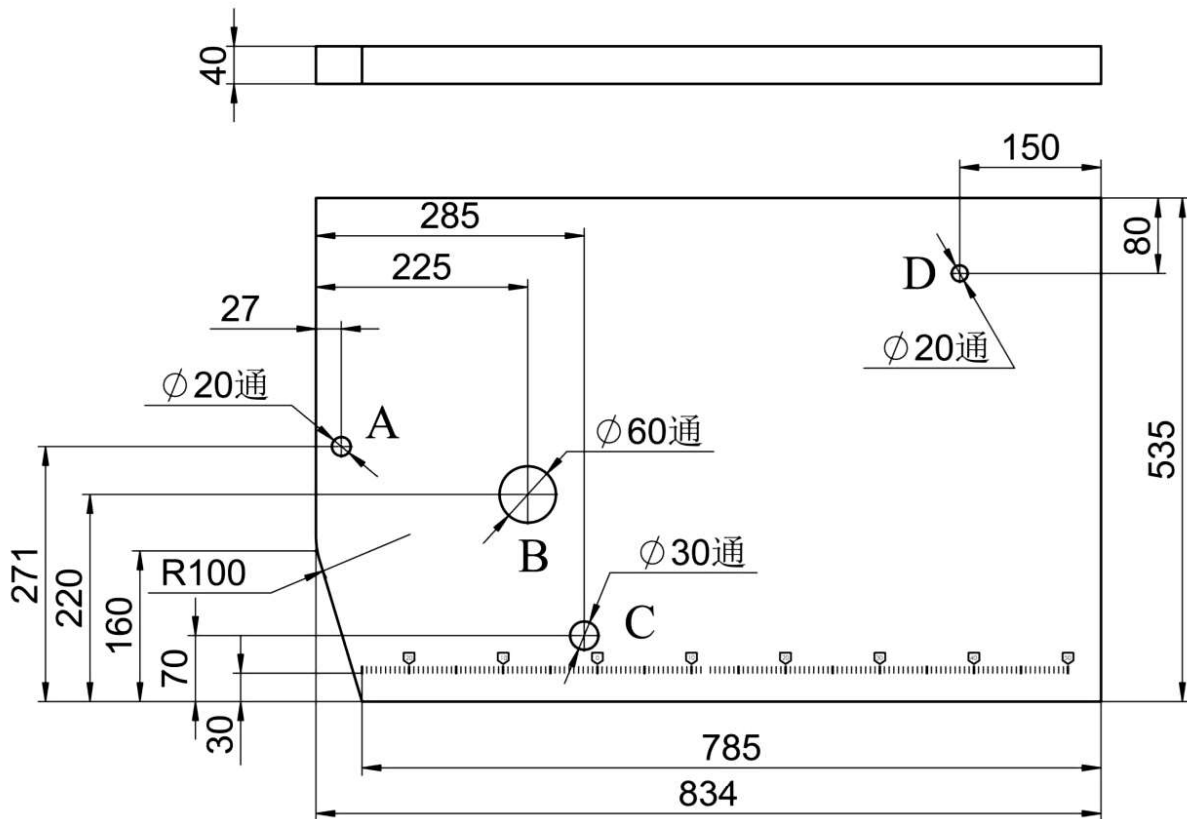

A. 链条过孔
Chain guidance hole

B. 电控线过孔
Electric control line hole

C. 调速器线过孔
Governor line hole

D. 线螺孔
Cotton stand hole

4. 安装方法 / INSTALLATION

⚠ 注意 CAUTION



请让受过培训的技术人员来安装缝纫机。



请委托购买商店或电气专业人员进行电气配线。



缝纫机重56公斤，安装工作必须由两人以上来完成。



在安装完成前，请不要连接电源，如果误按起动开关，缝纫机动作会导致受伤。



缝纫机头倒下或竖起时，请用双手进行操作。

单手操作时，因缝纫机的重量，万一滑落易致受伤。



The sewing machine should only be installed by a qualified technician.



Ask your dealer or a qualified electrician for any electrical work that may need to be done.



The sewing machine weighs more than 56kg. The installation should be carried out by two or more people.



Do not connect the power cord until installation is complete., otherwise the machine will operate if the treadle is pressed by mistake, which could result in injury.



Be sure to connect the ground. If the ground connection is not secure, serious electric shocks will result.

Install the pulley cover to the machine head.

4-1. 机头安装 / Installing the machine head

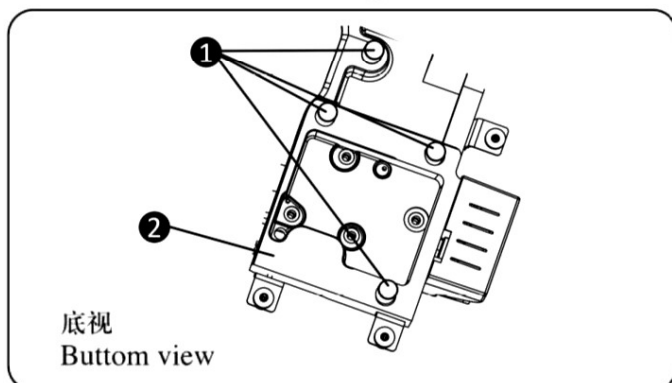

1. 把四个橡皮垫 ① 安放在机器和台板之间。

1. Insert four bar cushions ① into the holes in the bottom of the bed.

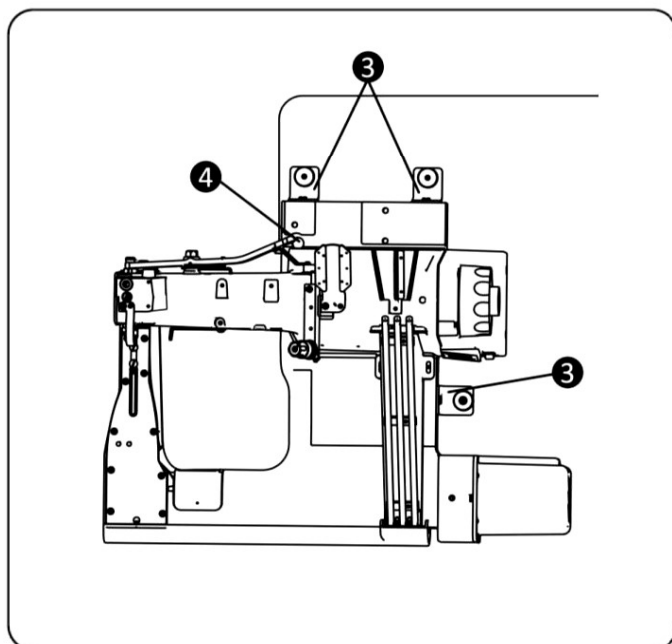

2. Place the machine head on the tabel, adjust its position by aligning it with the hole for presser bar lifter chain ④.

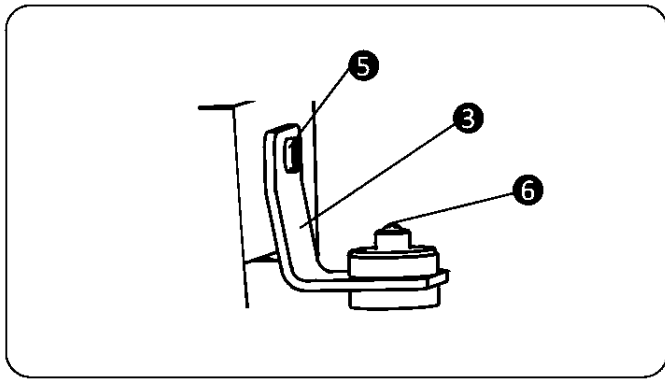

3. 用螺钉 ⑤ 把固定板 ③ 固定到机座上，再用螺钉 ⑥ 把固定板 ③ 固定到台板上。

3. After fastening cushions ③ to the machine bed and pulley cover base with set screws ⑤, fix them to the table with screws ⑥.

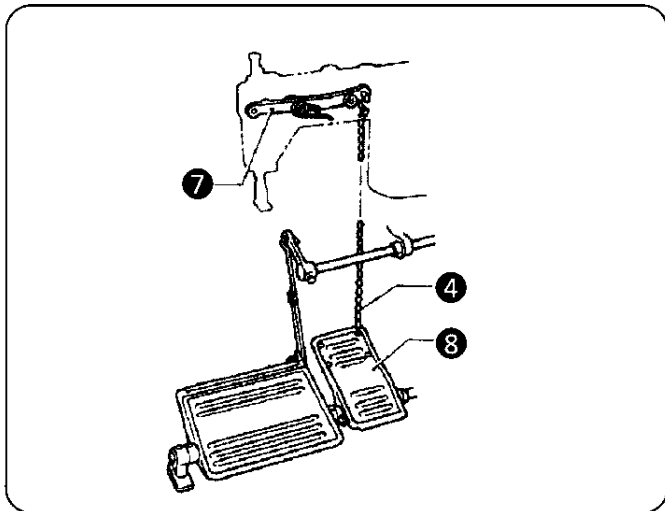

4. 把踏脚链同膝控抬压杆和压脚踏板相连。

4. Connect the presser bar lifter chain ④ to the knee lifter lever ⑦ and the presser lifter pedal ⑧.

4-2. 线团架 / Cotton stand

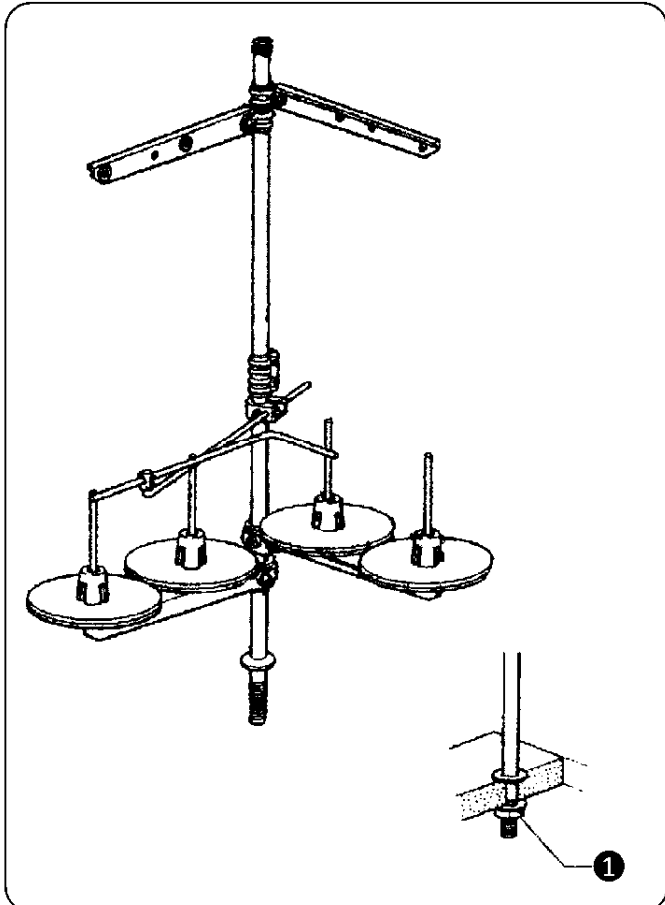

1. 参照线团架说明手册来安装线团架。

2. 用螺母把线团架安装到台板线团架。

1. Assemble the cotton stand while referring to the cotton stand instruction manual.

2. Install the cotton stand to the cotton stand mounting hole in the work table with the nut ①.

4-3. 润滑油 / Lubrication

⚠ 注意 CAUTION

- ⊘ 使用润滑油和黄油时，务必戴好保护眼镜和保护手套等，以防润滑油落入眼中或沾在皮肤上，这是引起发炎的原因。
另处，润滑油或黄油不能饮用，否则会引起呕吐和腹泻。
- ⊘ Be sure to wear protective goggles and gloves when handling the lubricating oil, so that no oil gets into your eyes or onto your skin, otherwise inflammation can result.
Furthermore, do not drink the oil under any circumstances, as it can cause vomiting and diarrhoea. Keep the oil out of the reach of children.

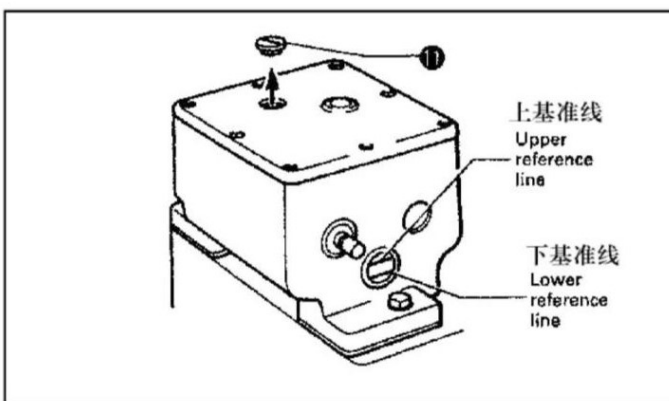
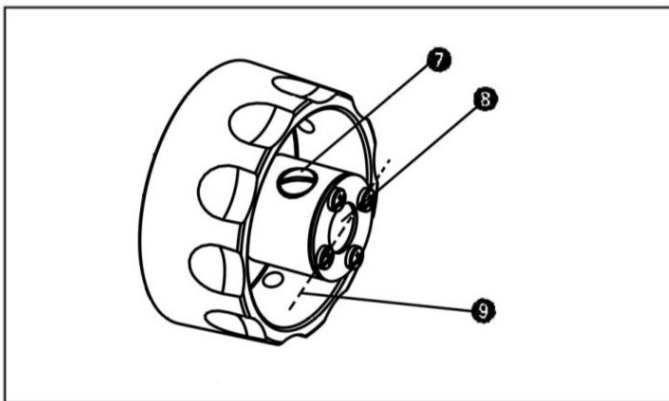
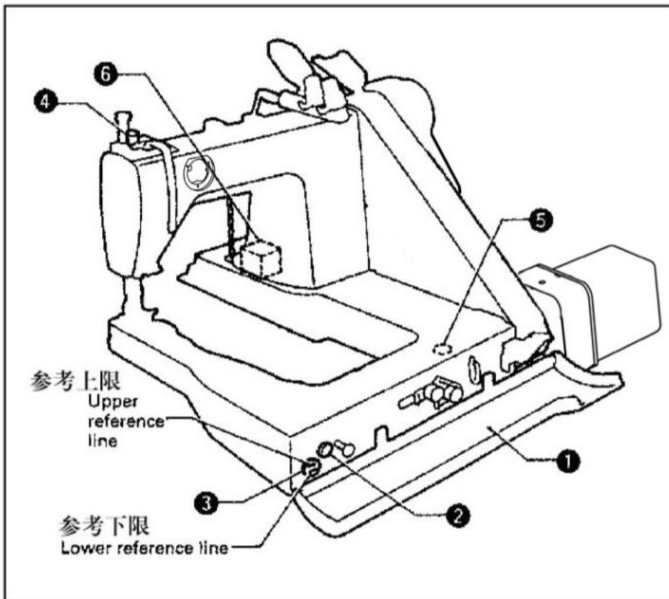

· 机器应经常润滑，在第一次用之前和长期未用之后油都要补充，只能使用我司指定的润滑油。

1. 打开前盖拿掉橡皮塞然后往里加油直至油量线达到油量参考线之间。
2. 插入橡皮塞然后关掉前盖。
3. 每周往针架润滑孔内加倒2滴油。
4. 定期松开油槽螺丝放开积存在机座前部油箱里的积油排开剩油后旋紧放油螺丝。
5. 定期用布擦除积存在机座后部油箱里的积油。
6. 旋转机器滑轮使油孔盖朝上然后拿掉油孔盖，往油箱里加满油。如果润滑油量低于油箱上的参考限度的中点那么上部的杆就没有油流入了，这样就不能得到充分的润滑。确保使得润滑油保持在参考线的中部以上。
7. 旋紧油孔盖。

* 如果机器是由附带的马达带动的则拿掉盖子上的螺丝，加油直至油量达到油箱上的参考上限；如果油量降至参考下限，务必要加油润滑完成后，旋紧盖面螺丝。

The sewing machine should always be lubricated and the oil supply replenished before it is used for the first time, and also after long periods of non-use.

Use only the lubricating oil (Nisseki Mitsubishi sewing Lube 15N; VG15) specified by our company.

1. Open the front cover ①, remove the rubber plug ②, and then fill with oil until the oil level reaches the point in between the reference lines on the oil gauge ③. If the oil level drops to the lower reference line, be sure to add more oil.
2. Insert the rubber plug ② and then close the front cover ①.
3. Add 1-2 drops of oil once a week to needle bar bracket lubrication hole ④.
4. Periodically loosen the oil drain screw ⑤ to drain out any oil which collects in the front bed oil sump.

After draining the oil, tighten the oil drain screw ⑤.

5. Periodically wipe away any oil which collects in the rear bed oil sump ⑥ with a cloth.

6. Turn the machine pulley, so that the oil hole cover ⑦ is facing upward, and then remove the oil hole cover ⑦ and fill the oil tank ⑧ with oil.

If the level of lubricating oil drops below the middle reference line ⑨ on the oil tank, no oil will thus not be lubricated sufficiently. Be sure to maintain the lubricating oil level at a level above the center reference line.

7. Attach the oil hole cover ⑦.

* If the machine is being used with the puller attached remove the cover screws ⑩ and fill with oil until the level reaches the upper reference line in the oil sight glass.

If the oil level drops to the lower reference line, be sure to add more oil.

After lubrication is completed, tighten the cover screw ⑪.

4-4. 检查机器的运转方向 / Checking the machine pulley rotating direction

⚠ 注意 CAUTION



缝纫过程中，不要触摸任何运动部件或物体靠在运动部件上，因为这会导致人员受伤或缝纫机损坏。



Do not touch any of the moving parts or place any objects against the machine while sewing, as this may result in personal injury or damage to the machine.

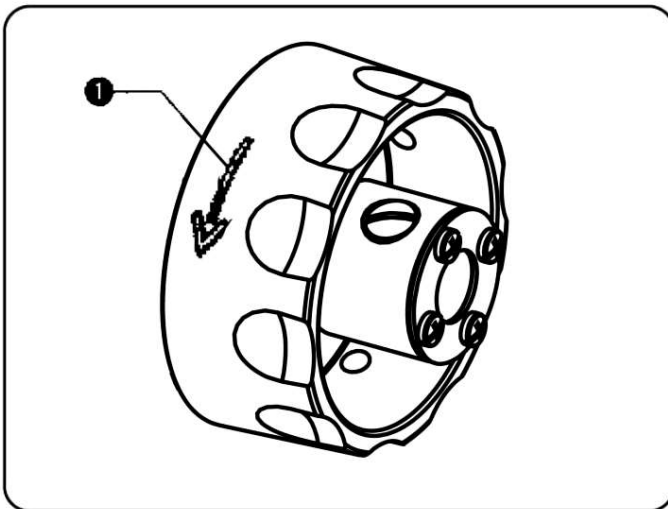

1. 把电源插入壁装电源插座然后打开动力开关。
2. 轻轻压下踏板检查机器滑轮能以箭头方向转动。若运转方向反了，根据电控说明手册把转动方向调整正确。在开始用的3,4天，要以500rpm的速度运转,低于正常的速度,这将有助于延长机器寿命。

1. Insert the power cord plug into the wall outlet, and then turn on the power switch.
2. Depress the treadle slightly and check that the machine pulley starts to turn in the direction of the arrow ①.

* If the direction of rotation is reversed, change the direction of rotation to the correct direction while referring to the instruction manual for the electronic control.

* For the first 3-4 days of use, run the machine at 500 rpm lower than the usual speed, This will help contribute t a longer service life for the machine.

5. 缝纫前的准备 / PREPARATION BEFORE SEWING

5-1. 针和线 / Needle and threads

使用的针线要根据缝纫面料线而异，参照以下表格选择正确的针线。

The needle and threads to be used vary depending on sewing conditions. Select the correct ones by referring to the able below.

针 Needle	线 Thread	
	Upper thread	Lower thread
TV×64 12#	80号纺纱 spun yarn #80	80号纺纱 spun yarn #80
TV×64 14#	60号纺纱 spun yarn #60	60号纺纱 spun yarn #60
TV×5 21#	30号纺纱 spun yarn #30	30号纺纱 spun yarn #30

5-2. 机针的安装方法 / Installing the needles

注意 CAUTION



在调整机针时，请先切断电源，当误按起动开关时，缝纫机动作会导致人员受伤。



Turn off the power switch before installing the needle, otherwise the machine may operate if the treadle is pressed by mistake, which could result in injury.

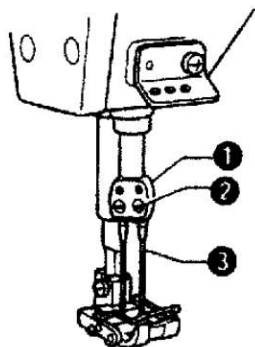

1. 转动滑轮直至最高位置。
2. 放松针固定螺丝，使针有长槽的一面面向前把它们插入针座，旋紧螺丝。

1. Turn the pulley until needle holder ① is raised to the highest position.
2. Loosen needle set screws ②, hold needles ③ with their long grooved side facing front, insert them into needle holder ① all the way, and fasten the needle with needle set screws ②.

5-3. 下线的安装 / Threading the lower threads

注意 CAUTION



在穿线以前先切断电源，当误按动起动开关时缝纫机动作会导致人员受伤。



Turn off the power switch before threading the upper thread, otherwise the machine may operate if the treadle is pressed by mistake, which could result in injury.

按下图穿底线。

Pass the lower threads as shown in the figure below.

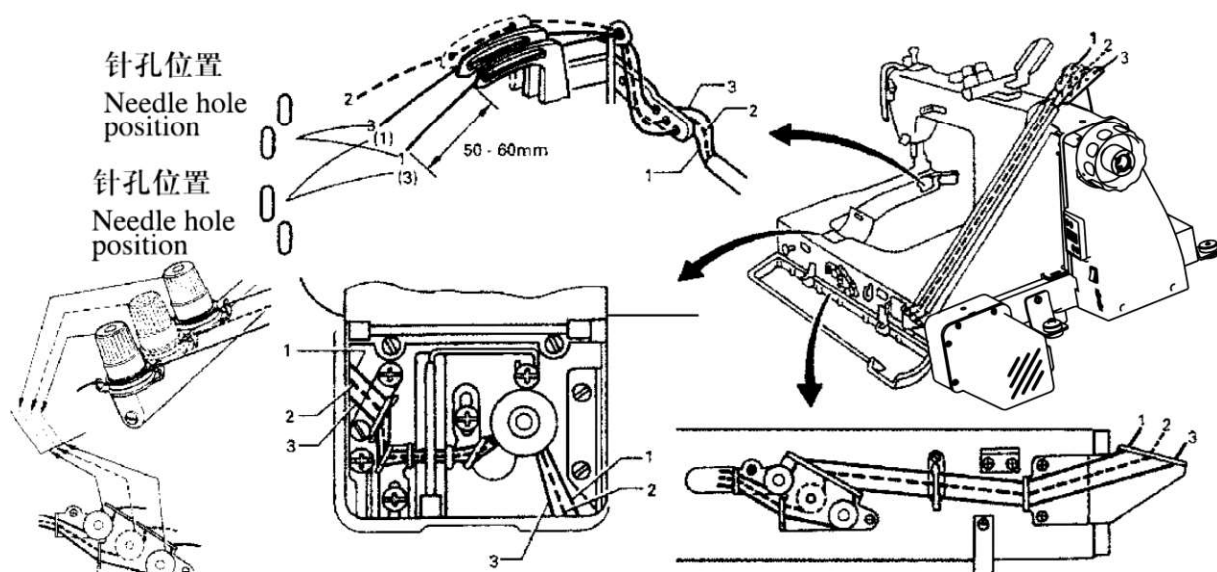

5-4. 上线的穿法 / Threading the upper threads

注意 CAUTION



在穿线以前先切断电源，当误按动起动开关时缝纫机动作会导致人员受伤。



Turn off the power switch before threading the upper thread, otherwise the machine may operate if the treadle is pressed by mistake, which could result in injury.

按下图穿上位线。

Pass the upper threads as shown in the the figure below.

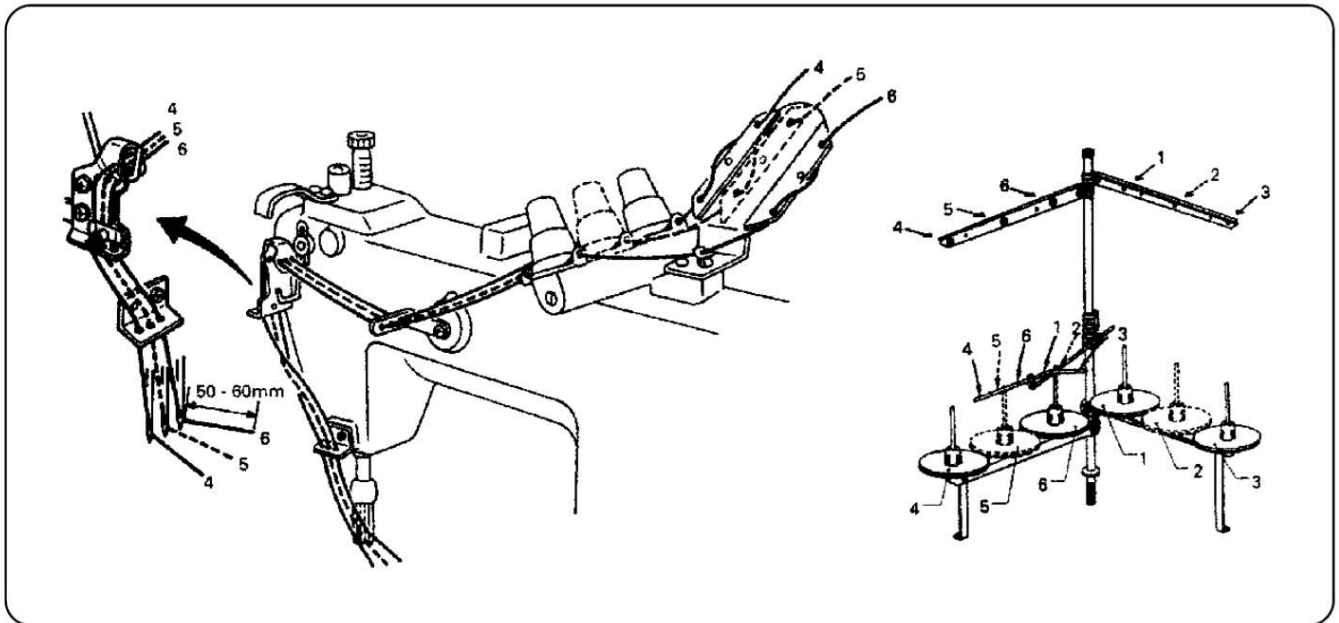

6. 缝纫 / SEWING

注意 CAUTION



- 为了安全起见，在使用本缝纫机之前，请安装保护装置。如果未安装这些安全装置就使用缝纫机，会造成人身伤害及缝纫机损坏。
- 发生下列情况时，请切断电源。
否则误按动起动开关，缝纫机动作会导致受伤。
 - 机针穿线时
 - 更换机针或梭芯时
 - 缝纫机不使用，或人离开缝纫机时。
- 缝纫过程中，不要触摸任何运动部件或将物件靠在运动部件上，因为这会导致人员受伤或缝纫机损坏。



Attach all safety devices before using the sewing machine. If the machine is used without these devices attached, injury may result.

Turn off the power switch at the following times. otherwise the machine may operate if the treadle is pressed by mistake, which could result in injury.

1. When threading the needle. 2. When replacing the needle. 3. When not using the machine and when leaving the machine unattended.

Do not touch any of the moving parts or place any objects against the machine while sewing. as this may result in personal injury or damage to the machine.

6-1. 缝纫 / Sewing

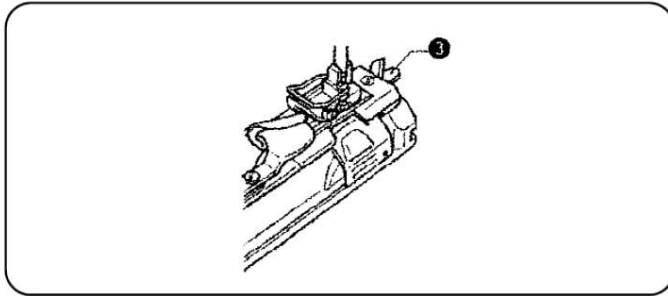
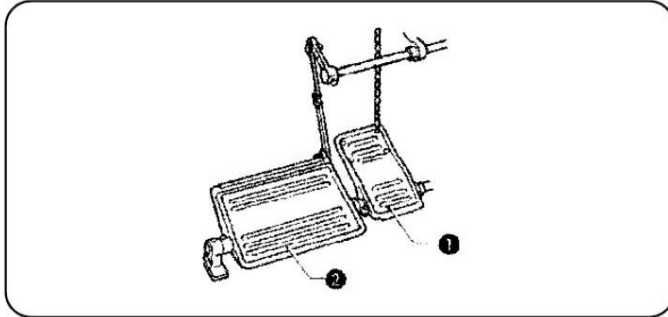

1. 打开电源。
2. 用脚压升降踏板 ①，让技工来完成工作。
3. 放开升降踏板。
4. 当踏下踏板时 ②，机器开始运转。
5. 当工作结束后将线剪断。

1. Switch the power on.
2. Depress presser lifter pedal ① and place the work under the presser foot.
3. Release the presser lifter pedal.
4. The machine starts running when treadle ② is stepped down.
5. After sewing the work, move the work to thread cutter ③ to make blank stitches, and cut the thread with it.

7. 缝纫效果 / THREAD TENSION

7-1. 调节线张力 / Adjusting the thread tension

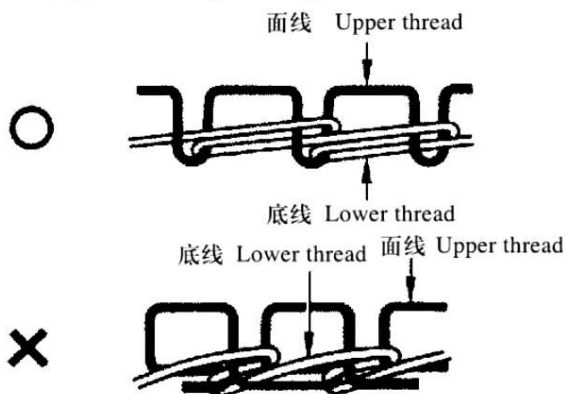

好的线迹
Good stitches

差的线迹
Loose, bad stitches
Appearance of seam when upper thread tension is too weak

当线夹夹线张力太弱时，就会露出接缝。

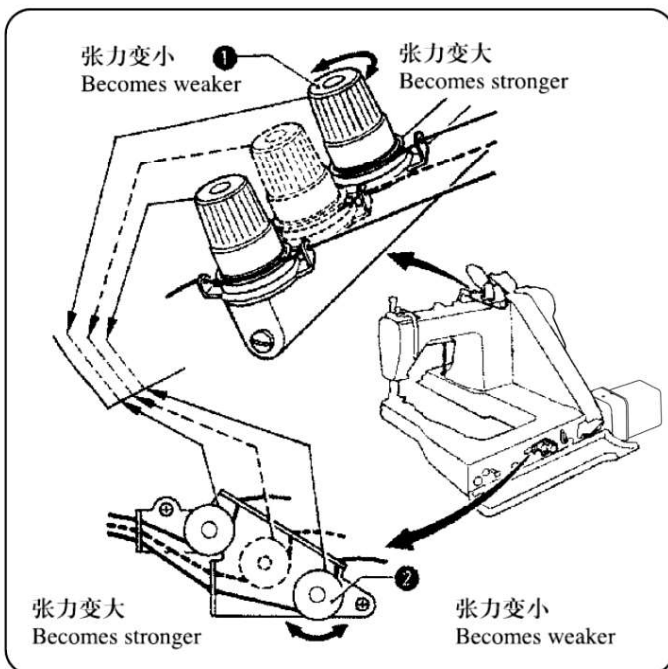

1. 通过旋转上部调节螺母 ① 缝地调节上部线的张力。

2. 通过转动底线调节螺母 ② 调节底线的张力。

1. Adjust the upper thread tension properly by turning upper thread adjusting screw ① .

2. Adjust the lower thread tension properly by turning lower thread adjusting screw ② .

7-2. 调节压脚压力 / Presser foot pressure adjustment

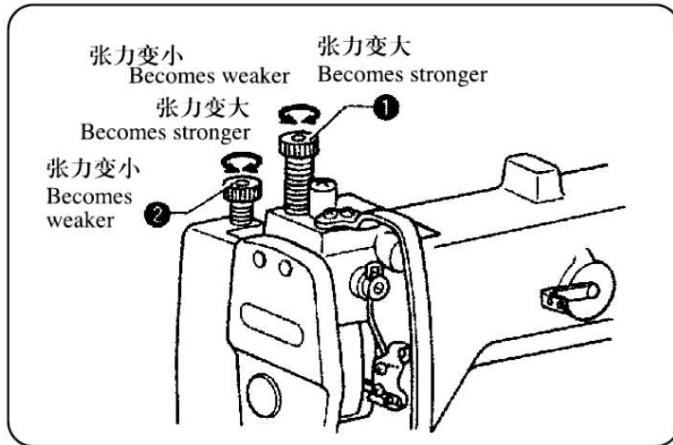

通过转动压脚调节螺丝 ① 调节压脚压力，使得压力正好能使布料顺利滑动。对于用电机带动的机器，可以通过转动压脚调节螺丝 ② 来合适地调整牵引压力。

Adjust the presser foot pressure by turning presser adjusting screw ① so that the pressure is just enough to feed the work positively and keep the work from slipping.

* In case of Machines with puller the puller pressure can be adjusted as appropriate to the work by turning presser adjusting screw ② .

7-3. 调节针距 / Adjusting the stitch length

⚠ 注意 CAUTION



在调节针距以前，请切断电源，当误起功开关时，缝纫机动作会导致人员受伤，然后等电机停止转功后才可以工作。



Turn off the power supply before adjusting the stitch length, otherwise the machine will operate if the treadle is pressed by mistake, which could result in injury.

However, the motor will keep turning even after the power is switched off as a result of the motor's inertia. Wait until the motor stops fully before starting work.

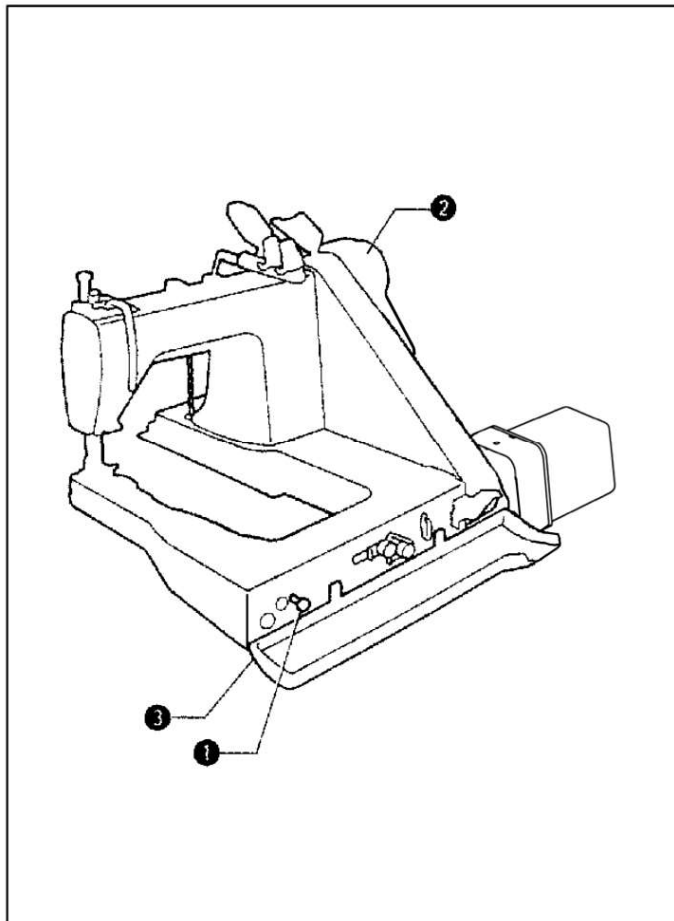

机器滑轮上的数字表示缝距但实际缝距则根据使用材料的类型和厚度而异，数值越高则缝距越大。放开调节按钮(检查调节按钮，使其调回)。

1. 打开前盖 ③。
2. 在压下调节按钮 ① 时，慢慢朝自己向里转动手轮 ②。
3. 继续压住调节按钮，继续轻动滑轮直至所需的针距。
4. 关掉前盖 ③。

说明:

不要在机器运转时压调节按钮 ①，因为这样可能严重损害机器零件，当用接近最大长度的缝制时，需要根据所用的线料类型来调节针距。

The numerals on the machine pulley scale represent the stitch length (mm), however the actual stitch length will vary depending on the type and thickness of material being used.

1. Open the front cover ③ .
2. While pressing the feed adjustment button ① , turn the machine pulley toward you slowly. (The feed adjustment button ① will move further inward.)
3. While still pressing the feed adjustment button ① , keep turning the machine pulley until the desired stitch length.

Release the feed adjustment button ❶. (Check that the feed adjustment button ❶ pops back out again.)

4. Close the front cover ❸.

NOTE:

Do not press the feed adjustment button ❶ while the machine is operating, as doing so may damage the machine parts.

When sewing with the stitch length set close to the maximum length, you will need to adjust the needle guard in accordance with the type of material and the type of thread being used.

7-4. 调节滑轮 / Puller feed adjustment (Machines with puller)

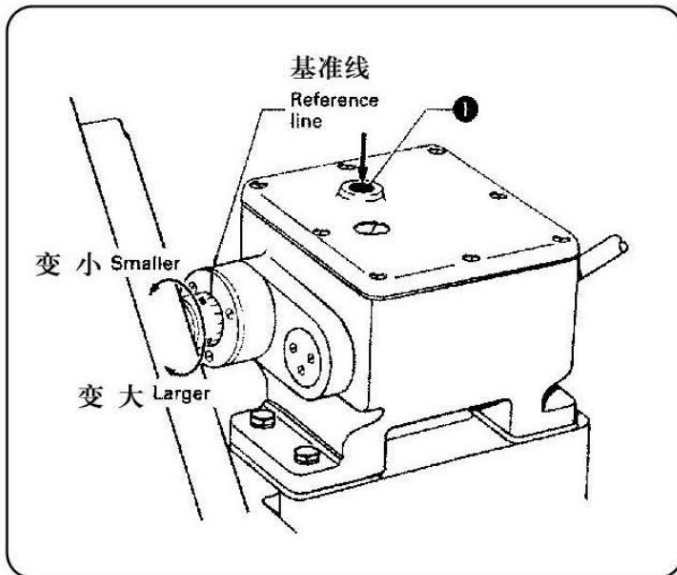

1. 用手指轻压调节按钮 ❶，同时朝自己转动滑轮，直至调节按钮更进一步。

2. 继续压住调节按钮，转动滑轮直至所需的参考线上的位置，滑轮朝自己转得越多缝制就越小。
*根据12页，在看过所形成的线迹后再调节牵引装置。

1. With feed adjusting button ❶ lightly pressed with your finger, turn the pulley toward yourself until feed adjusting button ❶ goes in one step deeper.

2. Keep pressing feed adjusting button ❶, and turn the pulley to set your desired feed position on the scale to the reference line.

The more you turn the pulley toward yourself, the smaller will be the feed.

*Adjust the puller feed after seeing the finished stitches of the work (Refer to page 12).

* The table below shows samples of stitches made with a highly elastic fabric and a fabric which is not so elastic. Adjust the puller feed by referring to this table

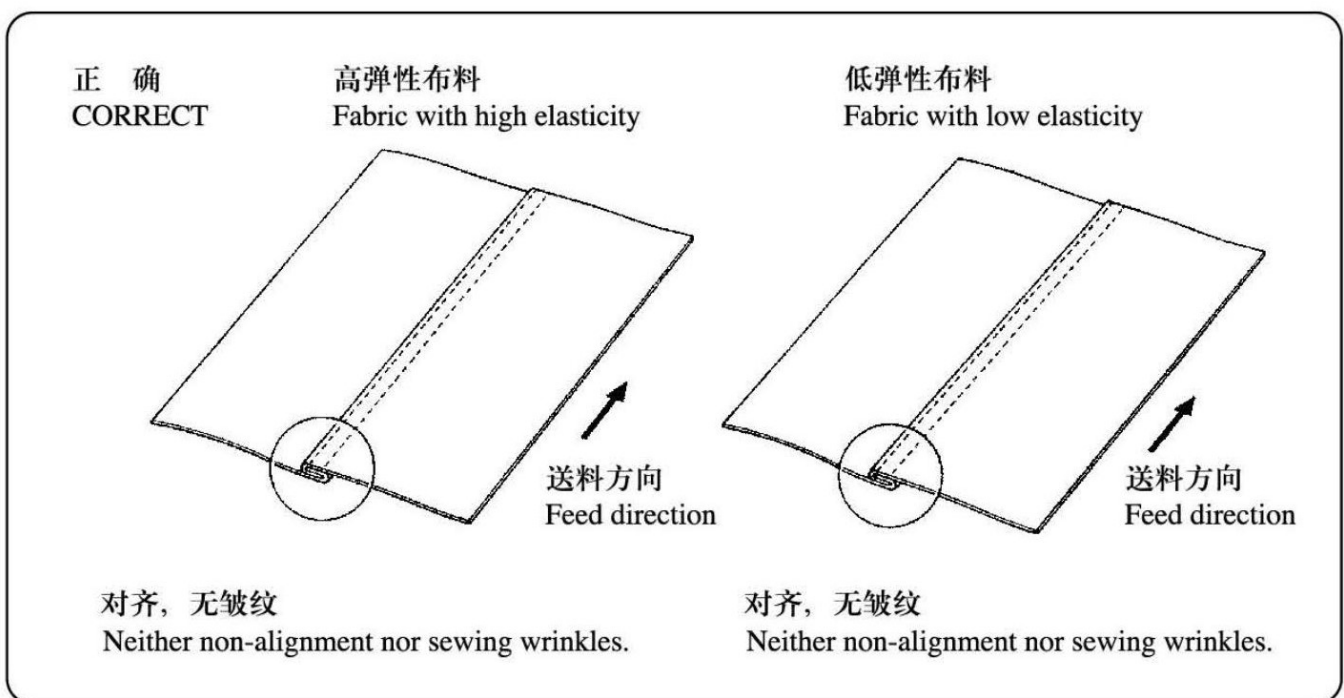

不充分
INSUFFICIENT

高弹性布料
Fabric with high elasticity

低弹性布料
Fabric with low elasticity

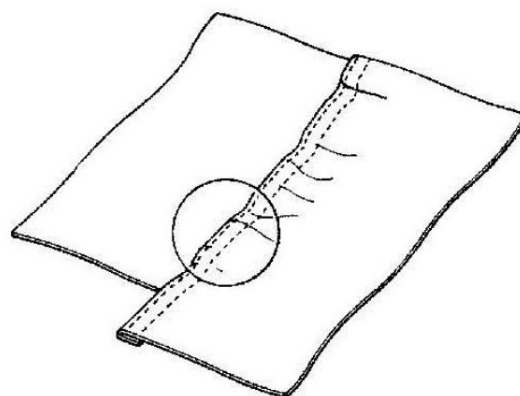
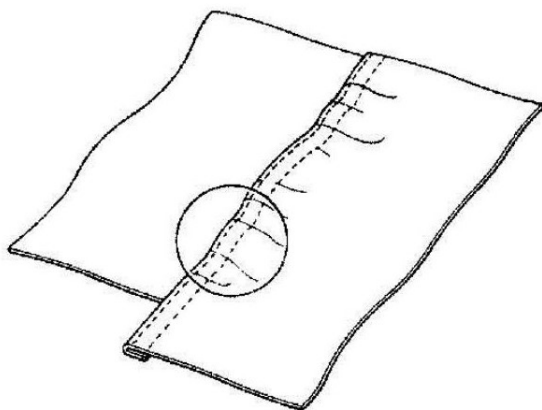

不整齐所有产生皱纹
Non-aligned, and wrinkled.

不整齐所有产生皱纹
Non-aligned, and wrinkled.

过度
EXCESSIVE

高弹性布料
Fabric with high elasticity

低弹性布料
Fabric with low elasticity

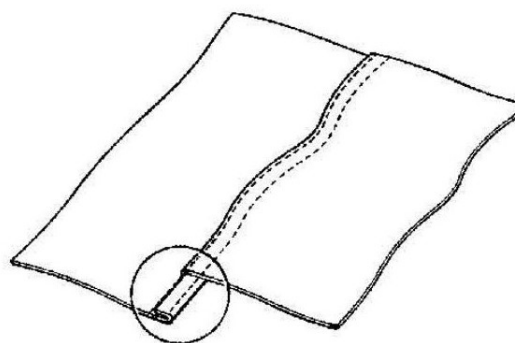
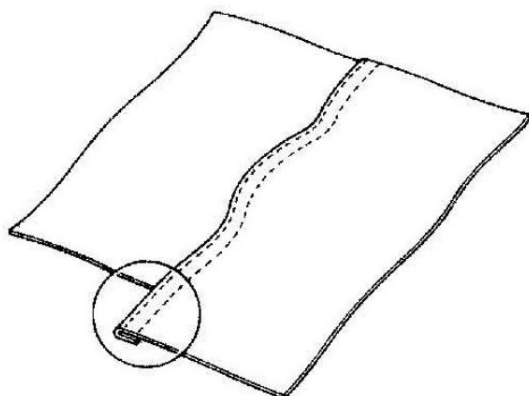

不整齐，波浪型明显
Non-aligned, and very wavy.

不整齐，波浪型明显
Non-aligned, and very wavy.

8. 保养 / CLEANING

为了保持缝纫机的机能，而且能长久的使用，请每天保养。

The following cleaning operations should be carried out each day in order to maintain the performance of this machine and to ensure a long servibe life.



注意 CAUTION



在开始清洁作业前，请切断电源。如果当误按动启动开关时，缝纫机动作会导致人员受伤。

使用润滑油和黄油时，务必戴好保护眼镜和保护手套等，以防润滑油落入眼中或沾在皮肤上，这是引起发炎的原因。

另外，润滑油或黄油不能饮用，否者会引起呕吐和腹泻。将油放在小孩拿不到的地方，缝纫机头倒下或竖起时，请用双手进行操作。单手操作时因缝纫机的重量万一滑落易导致受作。

为了保持缝纫机的机能，而且能长久的使用，请每天保养。另外，缝如果才时间未使用，请在进行了如下的保养后再使用。



Turn off the power switch before carrying out cleaning. The motor will keep turning even after the power is switched off as a result of the motor's inertia. Wait until the motor stops fully before starting work. The machine may operate if the treadle is pressed by mistake, which could result in injury. Be sure to wear protective goggles and gloves when handling the lubricating oil, so that no oil gets into your eyes or onto your skin, otherwise inflammation can result. Furthermore, do not drink the oil under any circumstances, as it can cause vomiting and diarrhoea. Keep the oil out of the reach of children.

8-1. 清洗 / Daily cleaning

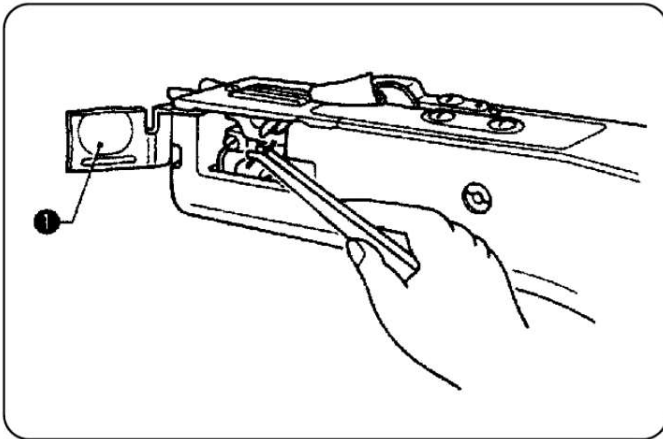

清洗机器

1. 打开绕线侧盖清理线料和其它废物。
2. 清洗完毕后，关上车盘。

润滑根据4-6润滑,第五页

1. 检查线穿的是否正确 (参照第9页)。
2. 若针尖断了要换掉。
3. 试缝。

Cleaning the machine

1. Open the looper side plate ❶ and clean away any thread scraps and other rubbish.
2. After cleaning, close the looper side plate ❶.

Lubrication

Refer to "4-6. Lubrication on page 5.

Checking

1. Check that the threads are threaded correctly. (Refer to page 9.)
2. If the tips of the needles are broken, replace the broken needles.
3. Carry out a trial sewing.

8-2. 更换润滑油(每三个月) / Changing the lubricating oil (every three months)

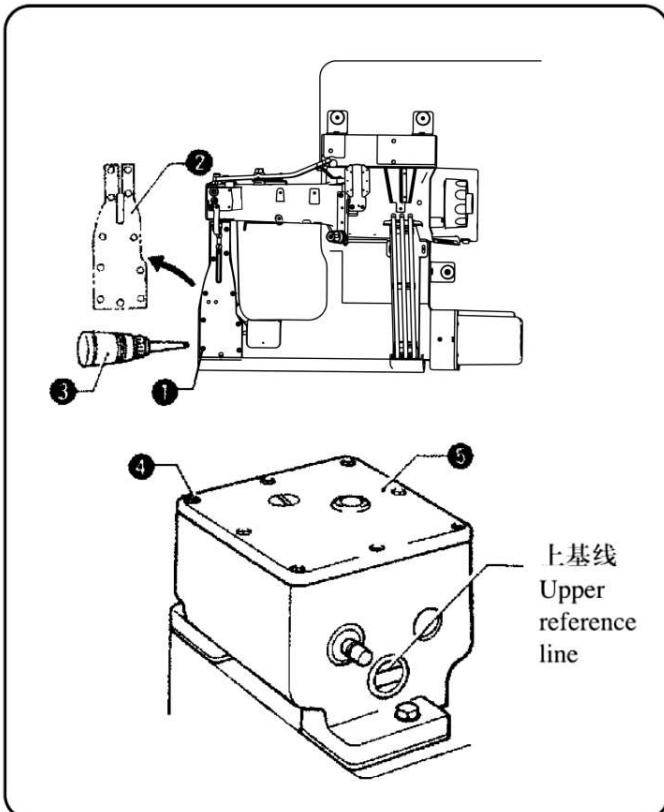

润滑油至少每3月换1次。旋开螺丝之后打开前盖把机器里所有的润滑油都倒入油瓶中，给机器加油直至油量线达到油箱上各参照线之间(参照第5页) 关上前臂盖，用11螺丝固定住。

1. 松开螺丝，然后打开顶部盖。
2. 把机器里所有的润滑油都倒入油瓶中。
3. 往里加油直至油量达到油箱上参照线(参第五)。
4. 关上顶部盖用螺丝固定住。

The lubricating oil should be changed at least once every three months.

1. Remove the 11 screws ❶, and then open the forward feed arm cover ❷.
2. Draw up all of the lubricating oil inside the machine into the oil bottle ❸.
3. Fill the machine with oil until the oil level reaches the point in between the reference lines on the oil gauge. (Refer to page 5)
4. Close the forward feed arm cover ❷ and secure it with the 11 screws ❶.

[Machine with puller]

1. Remove the eight screws ④, and then open the puller top cover ⑤.
2. Draw up all of the lubricating oil inside the machine into the oil bottle ③.
3. Fill the machine with oil until the oil level reaches the top reference line on the oil gauge. (Refer to page 5.)
4. Close the puller top cover ⑤ and secure it with the eight screws ④.

9. 标准调节 / STANDARD ADJUSTMENTS

⚠ 注意 CAUTION



只能由专业的服务人员来维护和检修叫一些我司的经销商或受过专业培训的技术员进行检修。

在进行检修时,请先切断电源,因为误按到开关,机子的运动会使人员受伤,马达被关闭后会保持运动一段时间,所以必须等马达完全停止后才能开始检修工作。



当需要维护和检修时,当更换易损件时。如果进行些必须使用电源来调整时请要特别注意安全如果一些安全装置还没有被装上,请将其装回原位并确保其正常使用。



Maintenance and inspection of the sewing machine should only be carried out by qualified personnel. Ask your dealer or a qualified electrician to carry out any maintenance and inspection of the electrical system.



Turn off the power switch and disconnect the power cord from the wall outlet at the following times, otherwise the machine may operate if the treadle is pressed by mistake, which could result in injury. However, the motor will keep turning even after the power is switched off as a result of the motor's inertia, Wait until the motor stops fully before starting work. When carrying out inspection, adjustment and maintenance. When replacing consumable parts such as the looper.

If the power switch needs to be left on when carrying out some adjustment, be extremely careful to observe all safety precautions.

If any safety devices have been removed, be absolutely sure to re-install them to their original positions and check that they operate correctly before using the machine.

9-1. 针杆高度的调节 / Needle bar height adjustment

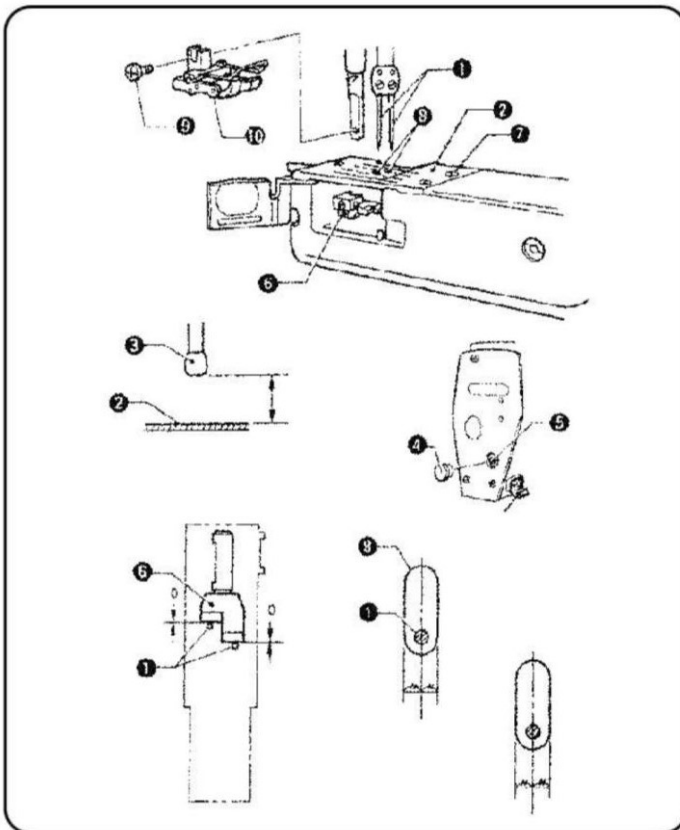

调整针的高度,同时,调整使得每根针都处于针板上的针孔中心拿橡皮塞松开针杆平紧螺丝并调整使得针底部和针板距离为11.3mm(对薄料)或10.1mm(对一般原料)。

如果针夹头按上述方式安装针夹抬至最高时,针尖的距离和针板顶部距离会是8.5mm(对于薄料)10.3mm(对于中等厚度的料)。

松开3个螺丝,之后拿开针板。

转动滑轮,使得针和护针排列起来。之后调节针板的斜度使得针左右和护针之间无间隙,用3个螺丝安装好针板,检查务必使得针处于针孔中心,拧紧护针螺丝。插入橡皮塞,用螺丝安装好压脚。

Adjust the heights of the needles ①.

At this time, adjust so that each needle ① is in the center of the needle hole ⑧ in the needle plate ②.

1. Remove the screw ⑨, and then remove the presser foot ⑩.
2. Turn the machine pulley to drop the needle bar to its lowest position.
3. Remove the rubber plug ④, loosen the needle

bar clamp screw ⑤ and adjust so that the distance between the bottom of the needle clamp ③ and the top of the needle bottom of the needle clamp and the top of the needle plate ② is 11.3mm (for thin materials) or 10. *If the needle clamp is set in the way described above, the distance between the points of the needles ① and the top of the needle plate ② will be 8.5mm (for thin materials) or 10.3mm (for medium thick materials) when the needle clamp ③ is raised to its highest position.

4. Remove the three screws ⑦, and then remove the needle plate ②.
5. Turn the machine pulley so that the needle ① and the needle guard ⑥ are aligned, and then adjust the tilt of the needle clamp ③ so that there is no space between the left and right needles ① and the needle guard ⑥ at this time.

Install the needle plate with the three screws ②, and after checking that the needles ⑦ are in the centers ① of the needle holes ⑧, tighten the needle bar clamp screw ⑤.

6. Insert the rubber plug ④.
7. Install the presser foot ⑩ with the screw ⑨.

9-2. 弯针和针的调整 / Needle and looper timing adjustment

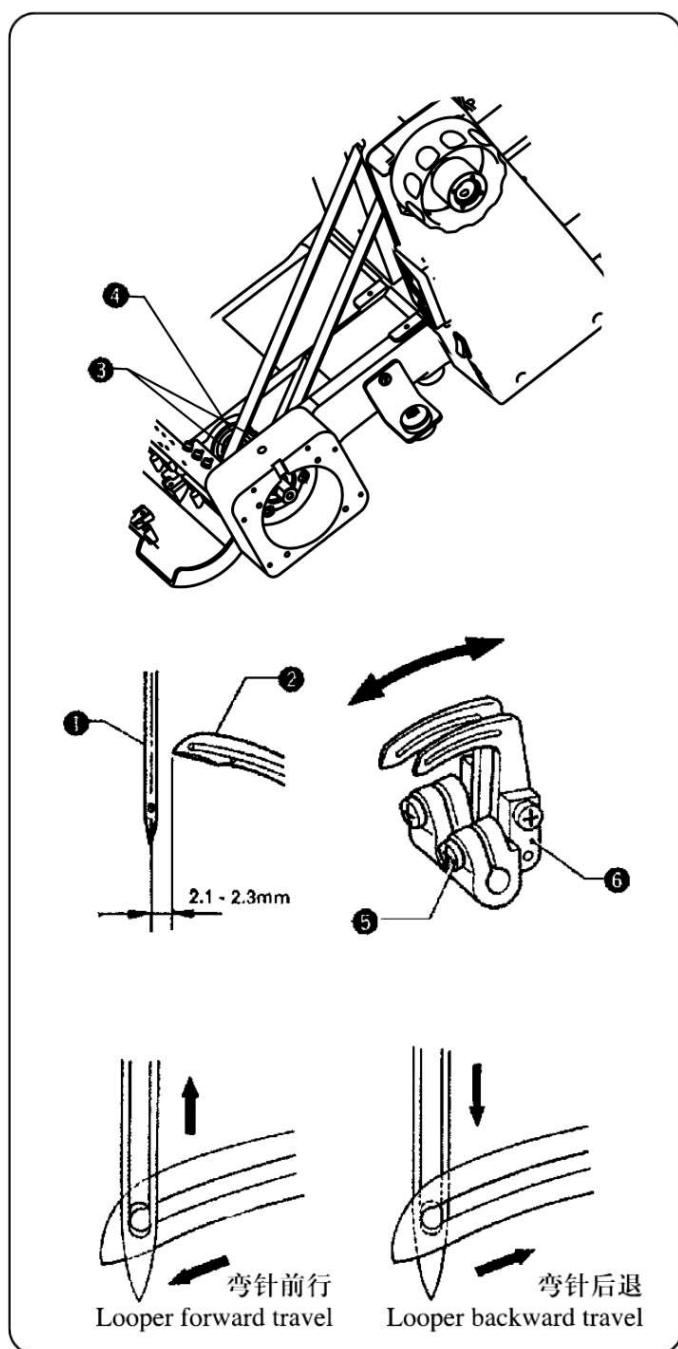

调节使得当针最低的时候，弯针处于最后端(右端)从针中心到弯针顶端距离为2.1-2.3mm。

1. 拿掉压脚针板和牙齿。
2. 拿掉电机罩壳、电机以及同步带罩壳。
3. 朝自己的方向转动滑轮直至弯针到达其最后部圈的末端。
4. 松开下面皮带轮上的2个定位螺钉。
5. 朝自己的方向转动滑轮，直至针下降至最低位置。
6. 拧紧定位螺钉。
7. 松开螺钉按箭头方向移开弯针直至针中心和弯针末端距离为2.1-2.3mm。
8. 务必使弯针过线孔和针眼在弯针前后圈上都对齐。
9. 装上电机、电机罩壳以及同步带罩壳。
10. 安上压脚针板和牙齿。

Make an adjustment so that, when needles ① are down lowest loopers ② reach the end of their backward travel and the distance from the needle center to the looper tip is 2.1 to 2.3mm.

1. Remove the presser foot, needle plate and feed dogs (Refer to page 14)
2. Remove the motor, motor housing and belt housing.
3. Turn the pulley toward yourself until loopers ② reach the end of their backward travel.
4. Loosen the two set screws ③ on lower belt wheel ④.
5. Turn the pulley toward yourself until needles ① come down to the lowest position.
6. Tighten set screw ③.

7. loosen set screw ⑤, move looper holder ⑥ in the arrow direction until the distance between the needle center and the looper tip is 2.1 to 2.3mm, and retighten set screw ⑤ securely.
8. Make sure that the looper thread eyes match the needle eyes in the forward and backward travels of the loopers.
9. Install the motor, motor housing and belt housing.
10. Install the presser foot, needle plate and feed dogs.

9-3. 调整弯针勾线 / Timing of loopers running clear of needles

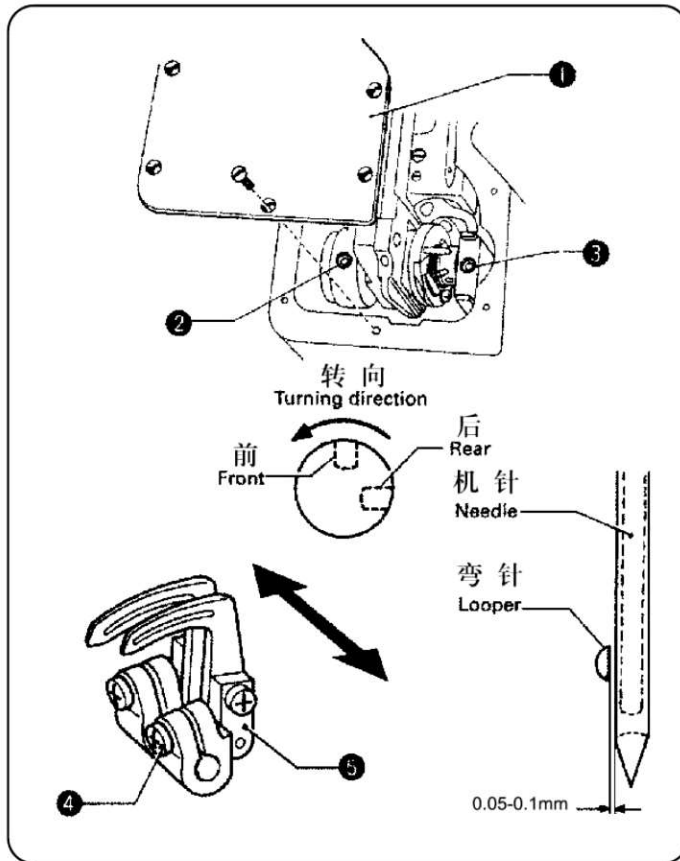

弯针不论向前、向后运转，弯针与机针的间距从0.05mm调至0.1mm。

1. 首先拿掉送料臂盖。
2. 调节前后绕线调速器使得前面与前后凸轮相连的螺钉同螺钉调节孔相一致。当前面的与上下凸轮相连的螺钉向绕线器相一致，而绕线器连接着杆调节孔松开后部与前后凸轮相连的螺钉之后松开前面的则螺钉使得前后凸轮可以调节，结束后拧紧2个螺钉。
3. 松开弯针架螺钉之后按箭头方向移动弯针架进行调节，使得弯针顶端和针中心与二者一致时距离为0.05-0.1mm同时，除了箭头所指示方向不要向其它方向移动弯针如果朝其它方向移动按照9-2进行调节弯针和机针(按15页)。
4. 安上送料臂盖。

The loopers run in back of the needles in their forward travel and in front of the needles in their backward travel. Adjust the clearance between the needles and the loopers to anywhere from 0.05 to 0.1mm in the forward travel.

1. Remove forward feed arm cover ② .
2. The forward/back looper timing should be adjusted so that the set screw which is at the front relative to the forward/backcamturning direction is aligned with the screw adjustment hole ③when the set screw which is at the front relative to the up/down camturning direction is alignedwith the looperconnecting rod adjustment hole ② .
To adjust, loosenthesetscrewwhichisat therearrelative to the forward/backcamturningdirection, andthen loosen the setscrew atthe front just enough so that the forward/backcam can be adjusted.
After adjusting,tightenthetwo set screws.
3. LoosentheLooperholder screw ④ , and thenmovethe looper holder ⑤ in the direction of the arrow toadjust so that the clearance between the tip of the looper and the center oftheneedleis0.05-0.1mm when the two are aligned.
At this time,do not move the looper holder ⑤ in any direction except the direction indicatedbythearrow. If itis moved in another direction, carry out the adjustments givenin"9-2.Adjusting the needle and looper timing" on page 15.
4. Install the forwardfeed arm cover ① .

9-4. 调整护针架 / Needle guard adjustment

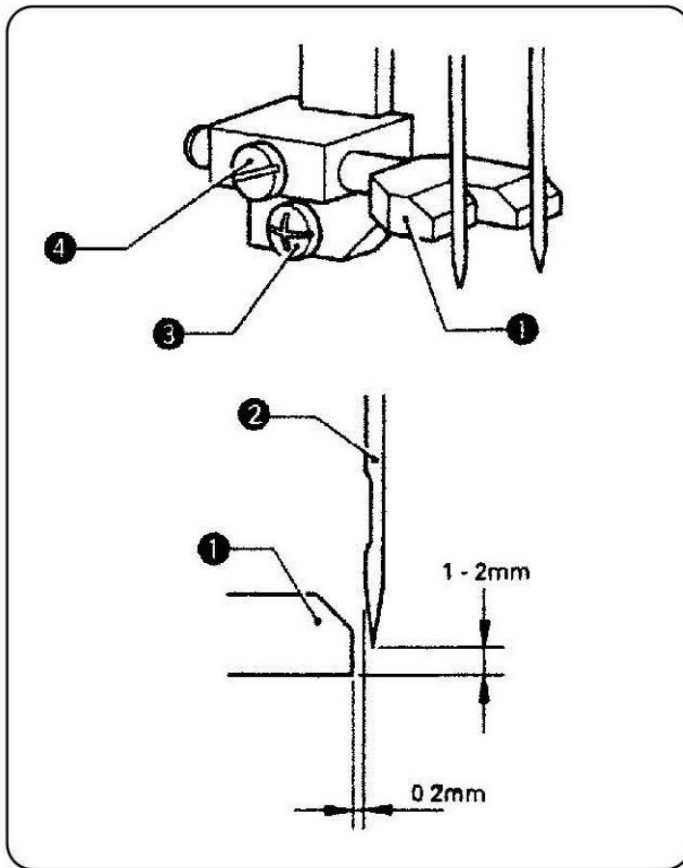

当缝距最小且弯针朝针运动时，护针架和针之间的距离应当是0.2mm，应将高度调节至使弯针不折断，高度应尽量最低。

1. 将缝距调到最小。
2. 朝自己方转动滑轮使弯针与针中心平行。
3. 松开螺钉③之后调高或降低针护架，使得从护针架底部到针尖距离为1-2mm。
4. 拧紧螺钉。
5. 松开螺钉④之后向左或右移动护针架进行调节使得针护和针之间的距离为0.26mm。
6. 拧紧螺钉。

说明：

对一些料、线如果缝距调至实际缝距时可以得到最好效果。

[For movable needle guard]

The clearance between the needle guard ① and the needles ② should be 0.2 mm when the stitch length is at the minimum setting and the loopers are moving toward the needles.

The heights should be adjusted to as low a setting as possible without the loopers breaking.

1. Adjust the stitch length to the minimum setting. (Refer to page 10.)
2. Turn the machine pulley toward yourself to align the loopers with the centers of the needles.
3. Loosen the set screw ③, and then raise or lower the needle guard ① so that the distance from the bottom of the needle guard ① to the points of the needles is 1-2 mm.
4. Tighten the set screw ③.
5. Loosen the set screw ④, and then move the needle guard ① to the left or right to adjust so that the clearance between the needle guard ① and the needles is 0.2 mm.
6. Tighten the set screw ④.

NOTE:

For some materials and threads, the best results can be obtained if the needle guard and the needle are touching slightly when the stitch length is adjusted to the actual stitch length.

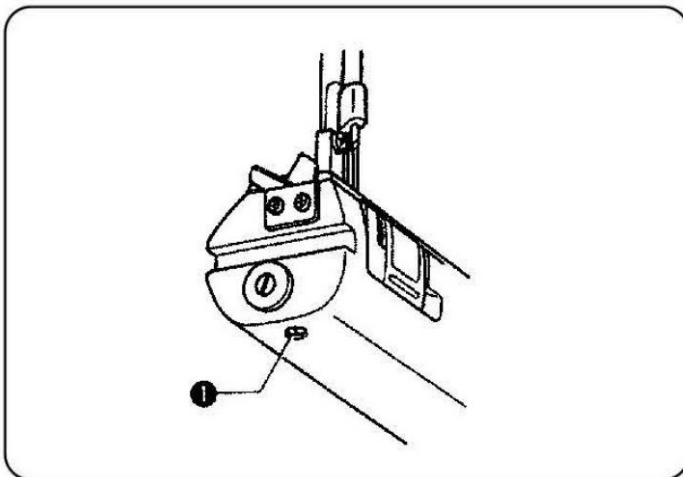

护针架使得针不与弯针在前圈接触，尽可能地使护针架接近针，但不能相互碰到。

1. 朝自己轻动滑轮直至针至最低位。
2. 松开护针支架螺钉。
3. 调节针和护针架之间的距离，通过移动护针架将其调至0.2-0.3mm。
4. 调节完后重新拧紧螺钉。

[For fixed needle guard]

The needle guard prevents the needles from contacting the loopers in their forward travel. Position the needle guard as close to the needles as possible but

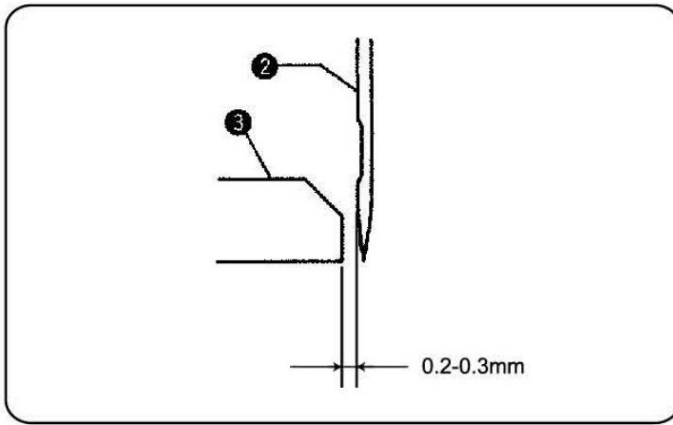

make sure that it is clear of the needles.

1. Turn the pulley toward yourself until the needles come down to the lowest position.
2. Loosen lower set screw ❶ at the end of the forward feed arm.
3. Adjust the clearance between needles ❷ and needle guard ❸ to anywhere from 0.2 to 0.3 mm by moving needle guard ❸.
4. After the adjustment, retighten set screw ❶ securely.

9-5. 送料牙的高度调节 / Feed dog height adjustment

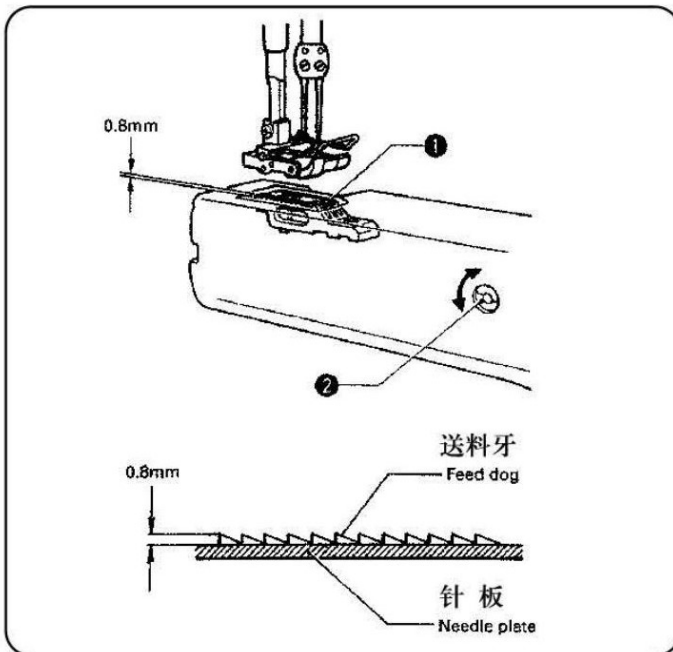

调节送料齿高度使得当送料齿处于最高处时，与针板顶部相距0.8mm。转动送料杆偏心轴来调节送料齿的高度。

Adjust the height of feed dog ❶ so it is 0.8 mm above the top of the needle plate when feed dog ❶ is at the highest position.

Adjust the height of feed dog ❶ by turning feed bar eccentric shaft ❷.

9-6. 上过线的调节 / Upper thread take-up thread guide adjustment

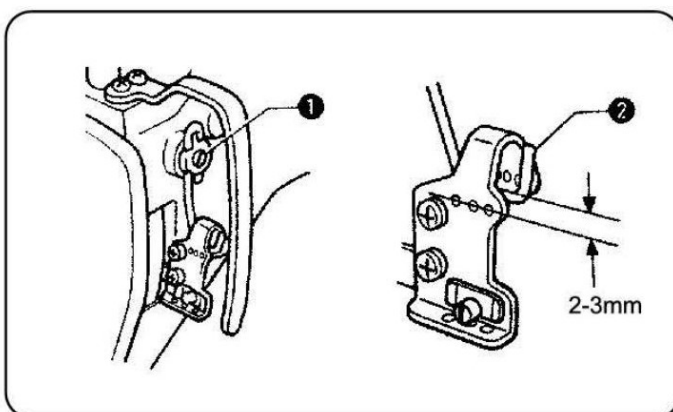

调节上紧线器孔的中心和引线器的顶部距离为2-3mm。

1. 朝自己轻动滑轮直至针杆处于最低位。
2. 松开螺钉之后上下调节上紧线器使得从紧线器至紧线器孔距离为2-3mm上紧线器越高面线圈越大。
3. 拧紧螺钉。

Adjust the distance between the center of the upper thread take-up and the top of the thread guide will be 2~3mm.

1. Turn the pulley toward yourself until the needle bar is down at the lowest position.
2. Loosen the screw ❶, and then move the upper thread take-up thread guide ❷ up or down to adjust so that the distance from the top of the upper thread take-up thread guide ❷ to the center of the upper thread take-up hole is 2-3 mm.

* The higher the upper thread take-up thread guide ❷, the greater will be the upper thread loops.

3. Tighten the screw ❶.

9-7. 上线引导器的调节 / Upper thread arm thread guide adjustment

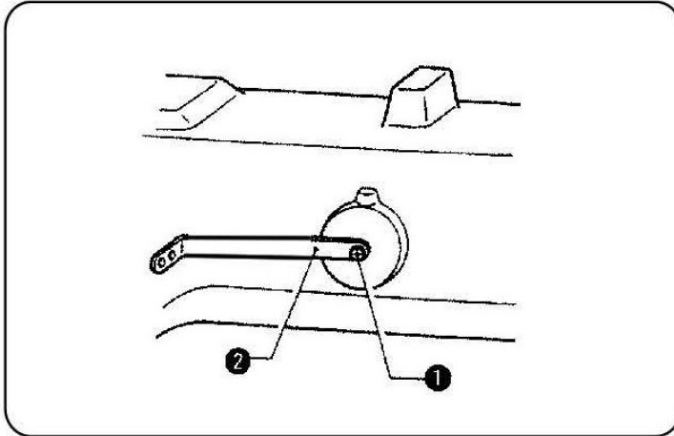

调节上线引导器使得上线当绕线器转完线圈时，有少许张力。

1. 松开螺钉，之后调节使得上线引导器几乎水平。
2. 调节完后，拧紧螺钉。

Adjust the upper thread arm thread guide so that the upper thread has a slight tension when the loopers run out of upper thread loops.

1. Loosen the screw ①, and then adjust so that the upper thread arm thread guide ② is nearly horizontal.
2. After the adjustment, retighten the screw ①.

9-8. 松线杆的调节 / Thread release shaft adjustment

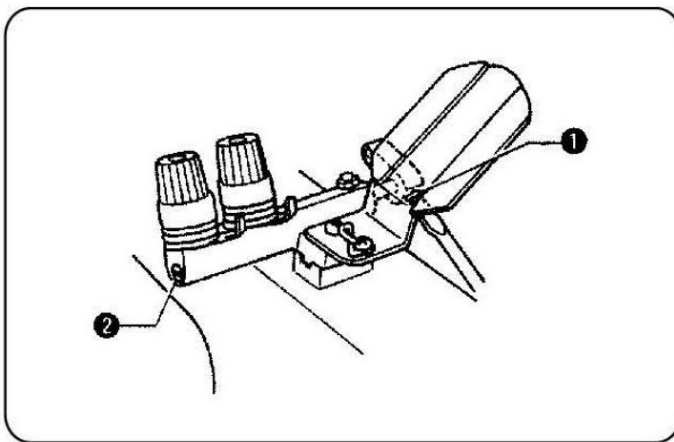

调节松线杆使得当压脚上升时，线张力小；压脚下降时，线张力大。

1. 松开帽螺钉。
2. 转动松线杆调节使得当压脚比针板顶部高4mm时线开始松弛。
3. 调整后拧紧螺丝。

Adjust the thread release shaft so that the thread tension discs loosen when the presser foot is raised and tighten when the presser foot is lowered.

1. Loosen set screw ①.
2. Make an adjustment by turning thread release shaft ② so that the thread tension discs begin to loosen when the presser foot rises 4mm above the top of the needle plate.
3. After the adjustment, retighten set screw ① securely.

9-9. 底线打线器的调节 / Lower thread take-up timing adjustment

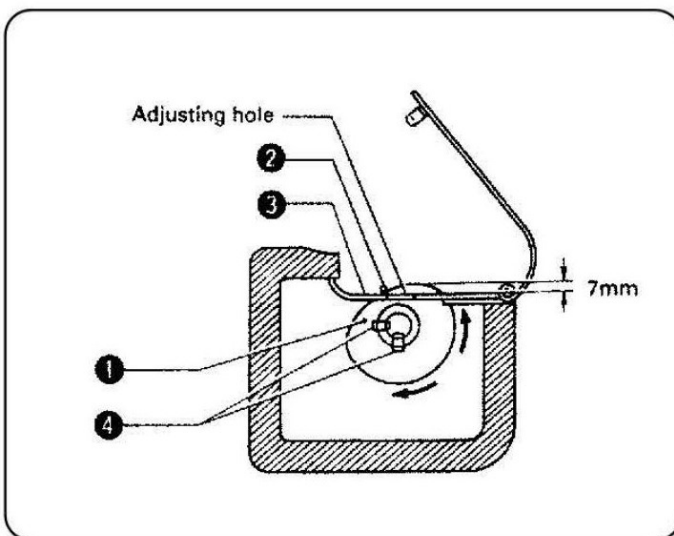

调节使得当绕线器开始向后移动时，低线紧线器与线接触，并比低线紧线器座高7mm。

1. 将螺丝起子插入低线紧线器底座的调节孔松开2个螺钉。
2. 升高底线紧线器直至比其低部高7mm。
3. 调完后拧紧2个帽螺钉。

Make an adjustment so that, when the loopers begin moving backward, lower thread take-up ② contacts thread ②, and is 7 mm up from lower thread take-up base ③.

1. Insert screwdriver through the adjusting hole in the lower thread take-up base, and loosen two set screws ④.

2. Raise lower thread take-up ① until it is 7 mm up from thread take-up base ③.

3. After the adjustment, retighten two set screws ④ securely.

9-10. 引导板的安装 / Installing the lapper

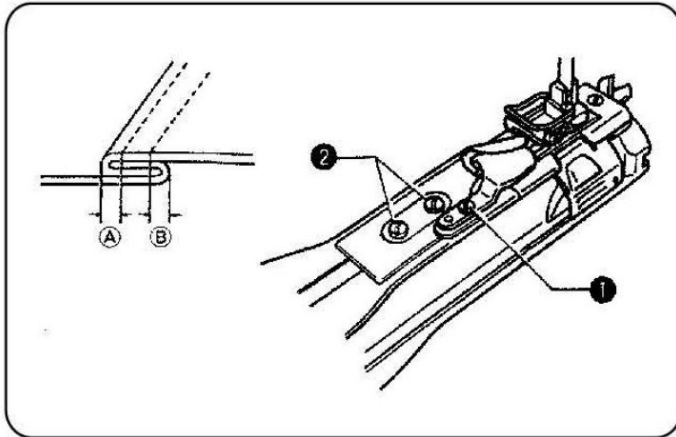

从前面将引导板插入送料臂盖前部椭圆形槽中，使得其末端与压脚留有空隙。松开帽螺钉调节下降距离点A，松开帽螺钉调节下降距离点B。调完后，重新拧紧帽螺钉。

Insert the lapper guide plate from the front into the oval slot in the forward feed arm cover, making sure that the end of lapper is clear of the presser foot.

■ Lapper adjustment

Adjust feeling distance of point **A** by loosening set screw **1**.

After the adjustment, retighten set screw **1**.

Adjust feeling distance of point **B** by loosening set screw **2**.

After the adjustment, retighten set screws **2**.

9-11. 滑轮的调节 / Puller height adjustment (Machines with puller)

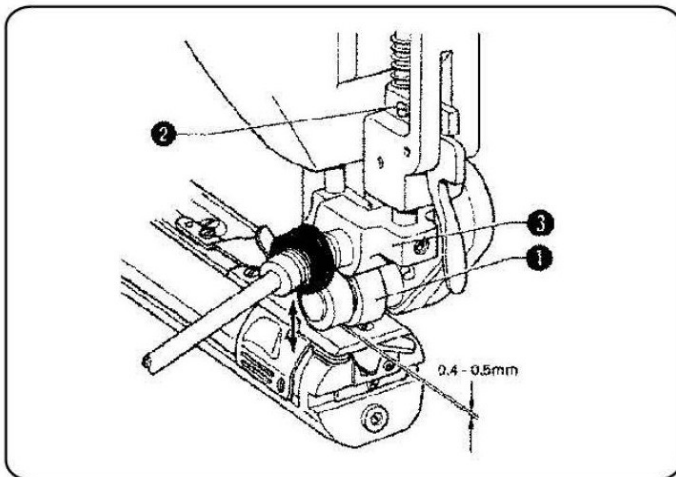

调节滑轮高度使得从针板顶部的距离为0.4至0.5 mm。松开螺钉上下移动滑轮支架直至滑轮比针板顶部高0.4mm到0.5mm调完后重新拧紧螺钉。

Adjust the height of puller **1** so that it is 0.4 to 0.5 mm high from the top of the needle plate.

Loosen set screw **2**, and move puller support **3** up or down until puller **1** is 0.4 to 0.5mm above the top of the needle plate.

After the adjustment, retighten set screw **2**.

9-12. 调速器的调节 / Puller timing adjustment (Machines with puller)

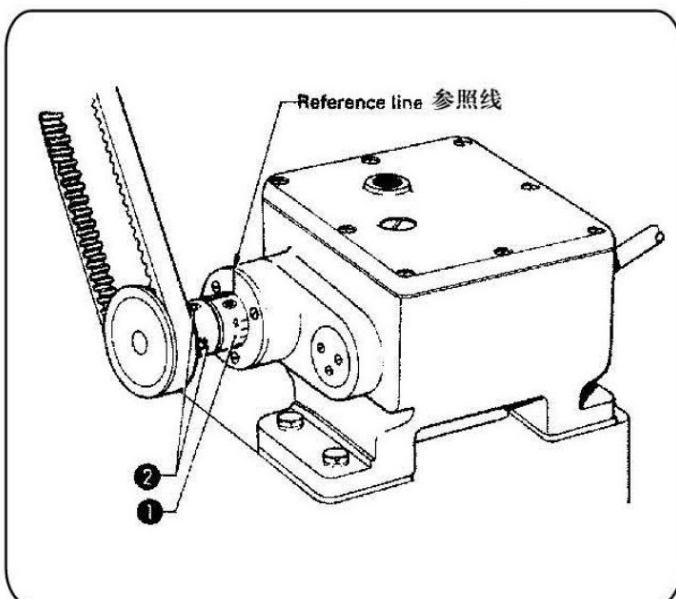

调节当针杆处于最低位时调速器上的标记处于参照线内：

1. 朝自己转动滑轮直至调速器上的标记处于参照线内。
2. 松开帽螺钉朝自己转动滑轮直至针杆一直下调。
3. 重新拧紧帽螺钉。

Make an adjust so that, when the needle bar is down at the lowest position, the mark on timing collar **1** is in line with the reference line.

1. Turn the pulley toward yourself until the mark on timing collar **1** meets the reference line.
2. Loosen two set screws **2**, and turn the pulley toward yourself until the needle bar is lowered all the way down.
3. Retighten set screws **2**.

10. 故障维修 / TROUBLESHOOTING

*请在你要求维修和服务前先检查以下几点。

*如果以下方法仍然不能解决问题关闭电源开关,向受过培训的技术人员经销商咨询。



注意



在检查以前请先切断电源缝纫机的动作会导致人员受伤。

然后必须等电机停机转动以后,才能进行检查工作。

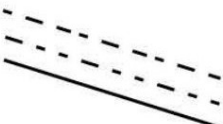
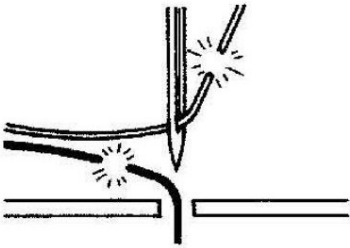
问 题	可能的原因	页
1. 上线不紧	上线张力太小或是下线张力太大。 调节上线张力或下线张力。 上紧线器位置不正确吗?	
2. 当缝纫时,有跳线迹。 	针安装是否合适? 正确调节上紧线器 若不正确则正确安装 绕线点迟缓? 用好的更换针和绕线调速器是否正确? 调节针和绕线调速器 针和弯针空隙不合适?	
3. 缝位不正确 (带滑轮机器)	底线调速器不正确? 调节滑轮调速器不正确? 调节滑轮送料器不正确? 压脚压力不正确? 调节压脚压力。 送料齿高度不正确?	
4. 机器无法送料	机器无法送料,送料齿太低? 调高。 压脚压力太小? 增加压力。 送料齿磨损,让维修工检查一下。 压脚浮动不能安全工作? 让维修工检查一下。 送料齿和压脚只有一个工作。	
5. 上线或下线断裂 	针弯了或针尖断了? 若是则换针。 针安装是否合适? 若不合适则正确安装。 线穿的合适吗? 若不合适则正确穿线。 上线下线张力太弱或太强,调节上线或下线张力。 松线杆位置合适吗? 调节。 针眼对线的太小吗? 参照针线选择。 绕线器损坏? 更换。	

- Please check the following points before calling for repairs or service.
- If the following suggestion do not solve the problem, turn off the machine power supply and contact your nearest Brother service center.



CAUTION



Turn off the power supply before adjusting the stitch length, otherwise the machine will operate if the treadle is pressed by mistake, which could result in injury.

However, the motor will keep turning even after the power is switched off as a result of the motor's inertia. Wait until the motor stops fully before starting work.

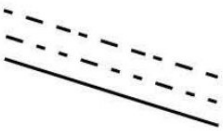
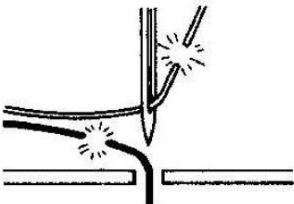
PROBLEM	POSSIBLE CAUSE	PAGE
1. Upper thread is not tight.	<ul style="list-style-type: none"> • Is the upper thread tension too weak, or is the lower thread tension too strong? Adjust the upper thread tension or lower thread tension. • Is the position of the upper thread take-up thread guide incorrect? Adjust the upper thread take-up thread guide position correctly. 	
2. Skipped stitches occur while sewing. 	<ul style="list-style-type: none"> • Is the needle properly installed? If it is incorrect, install the needle correctly. • Are the looper points dull? Replace looper with good ones. • Is the needle and looper timing incorrect? Adjust the needle and looper timing correctly. • Is the clearance between needles and loopers incorrect? Adjust the clearance between needles and loopers correctly. • Is the lower thread take-up timing incorrect? Adjust the lower thread take-up timing correctly. 	
3. Seam position is incorrect. (Machines with puller)	<ul style="list-style-type: none"> • Is the puller timing incorrect? Adjust the puller timing. • Is the puller feed incorrect? Adjust the puller feed. • Is the presser foot pressure incorrect? Adjust the presser foot pressure. • Is the feed dog height incorrect? Adjust the feed dog height. 	
4. Machine does not feed work.	<ul style="list-style-type: none"> • Is the feed dog too low? Adjust the feed dog height. • Is the presser foot pressure too small? Adjust the presser foot pressure. • Is the feed dog worn out? Have serviceman check it. • Presser foot floats and does not fully press work. Have serviceman check it. • Feed dog and presser foot work on one side only. 	
5. Upper and lower threads are breaking. 	<ul style="list-style-type: none"> • Is the needle bent or is the needle tip broken? Replace the needle if it is bent or broken. • Is the needle properly installed? If it is incorrect, install the needle correctly. • Is the needle properly threaded? If it is incorrect thread the needle correctly. • Is the upper or lower thread tension too weak or too strong? Adjust the upper thread or lower thread tension. • Is the thread release shaft position incorrect? Adjust the thread release shaft position correctly. • Are the needle eyes too small for threads? Refer to the section on "Needles and threads". • Are the loopers damaged? Replace loopers with good ones. 	

零件样本

Notes for using this parts book

目 录 CONTENTS

A. 主轴部件/Machine body.....	1
B. 上轴部件/Upper shaft mechanism.....	1
C. 针杆部件/Needle bar mechanism.....	3
D1. 抬压脚部件 (9270D) /Presser bar mechanism(9270D).....	3
D2. 抬压脚部件 (9280D) /Presser bar mechanism(9280D).....	5
E. 带轮部件/Pulley mechanism.....	5
F. 送料部件/Feed mechanism.....	7
G1. 零件关系 (9270D) /Gauge Parts(9270D Standard).....	9
G2. 零件关系 (9280D) /Gauge parts(9280D Standard).....	9
J. 下轴部件/Lower shaft mechanism.....	11
K. 弯针轴部件/Looper mechanism.....	13
L1. 上线过线部件 (9270D) /Upper threading mechanism(9270D).....	15
L2. 上线过线部件 (9280D) /Upper threading mechanism(9280D).....	17
M1. 下线过线部件 (9270D) /Lower threading mechanism(9270D).....	19
M2. 下线过线部件 (9280D) /Lower threading mechanism(9280D).....	23
2PL/PL 专用部件/Special components for 2PL/PL.....	27
PS 专用件/Spscial components for PS.....	29
Z1. 附件/Accessories.....	31
不同型号的零件清单/Different parts list.....	33

A. 主体部件/Machine body

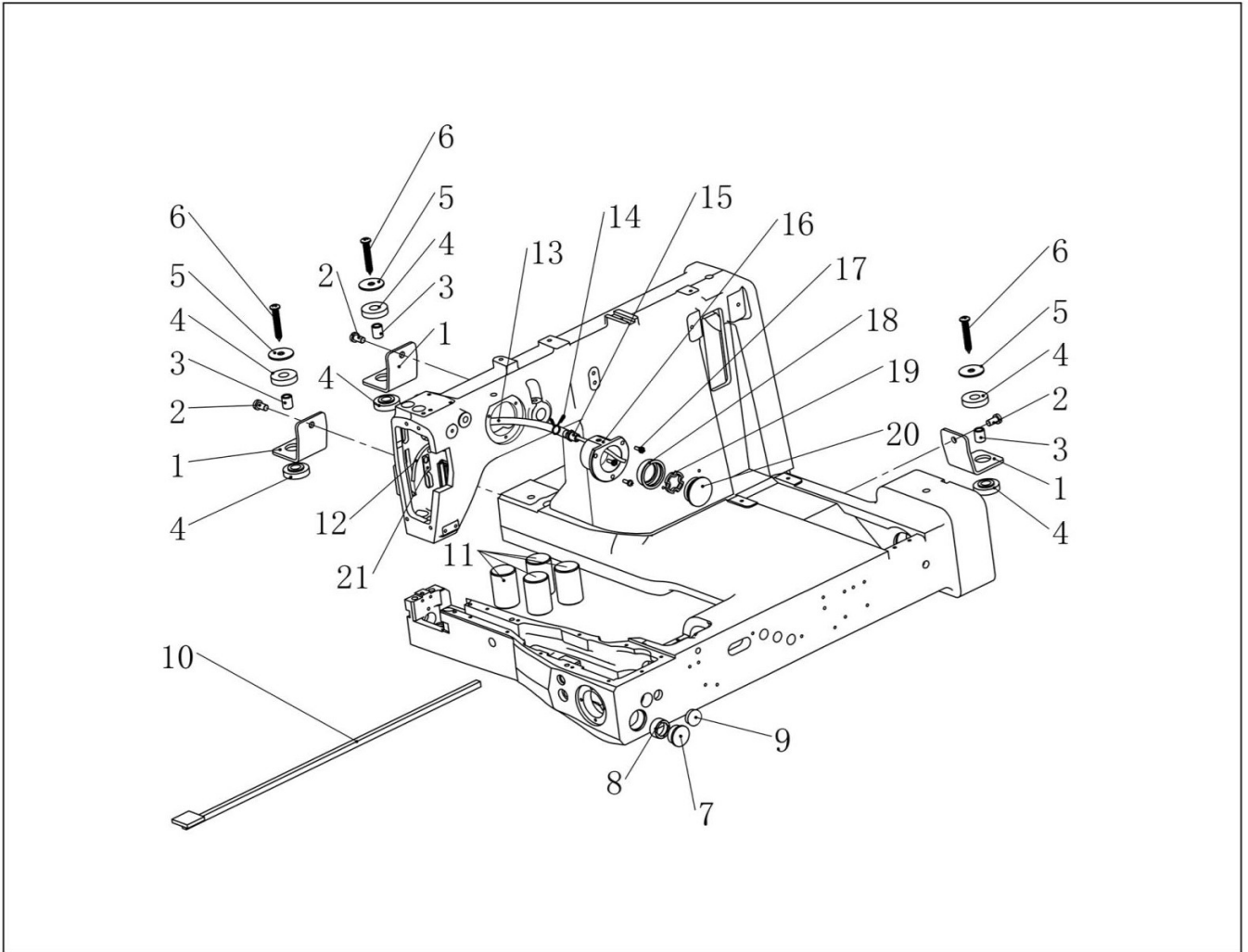

B. 上轴部件/Upper shaft mechanism

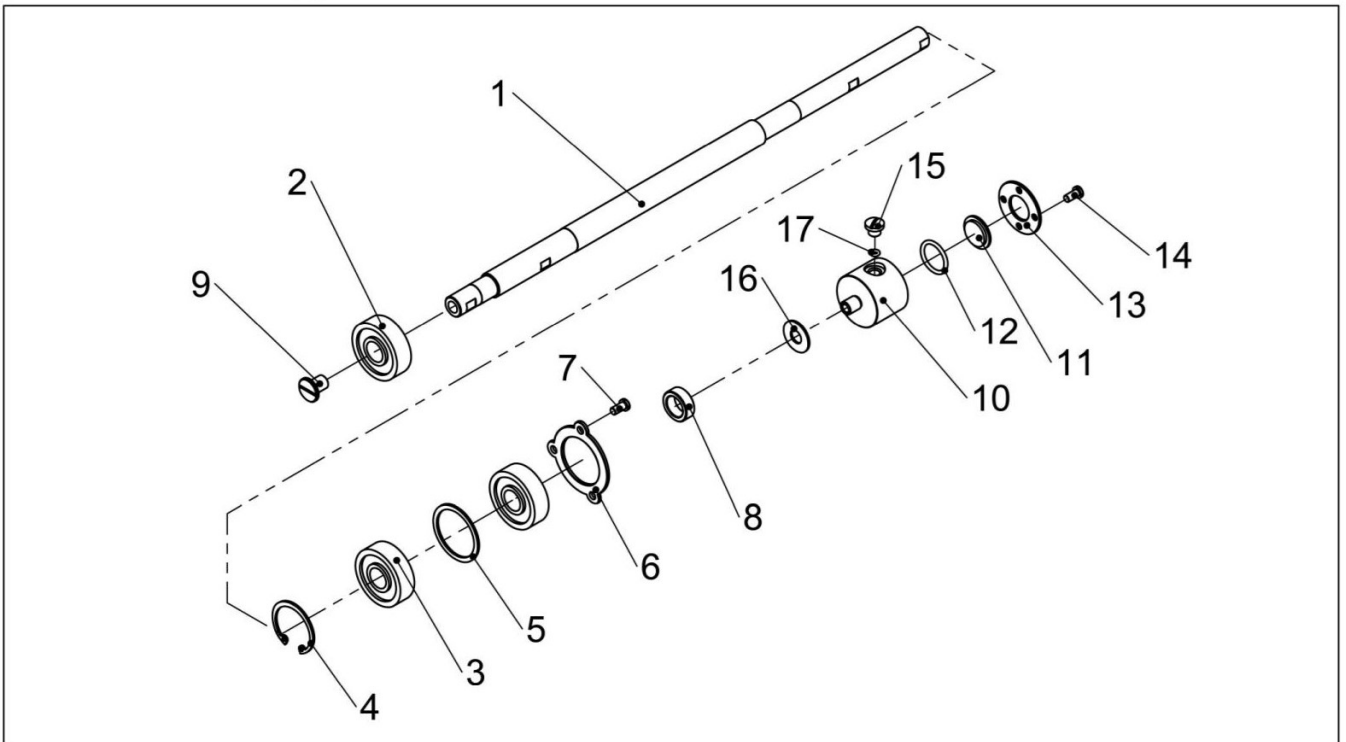

A. 主体部件/Machine body

序号 REF. NO.	件号 Part NO.	名称	Description	数量 Qty
1	40612001	底座固定板	Cushion assy	3
2	201S11029	螺钉	Screw	3
3	40603001	滚筒	Matress Protector	3
4	40622001	橡胶垫	Rubber pad	6
5	140628001	垫圈 6.5×25×1.5	Washer, 6.5×25×1.5	3
6	406S30001	自攻螺钉 M6.3×38	Self tapping screw, M6.3×38	3
7	20911003	油窗	Oil gauge window	1
8	20922003	油窗套	Oil gauge window bush	1
9	40622003	油封	Rubber cap, 15.5	1
10	40623003	回油线	Oil line	1
11	40622002	防震垫	Base cushion	4
12	40323013	油线 2×2(进口)	Oil line 2×2 (import)	-
13	12921006	维尼龙油管 φ6×φ8(进口)	Vynylon oil pipe, φ6×φ8 (import)	-
14	12912038	油管夹	Oil pipe clamp	1
15	12936004	油嘴管	Oil pipe mouse	1
16	140611001	储油盒	Oil box	1
17	421S11012	螺钉带垫 M3×10	Screw, M3×10	3
18	41722031	橡胶圈	Rubber ring	1
19	41711004	油窗盖	Oil window cover	1
20	41711022	挡片	Baffle	1
21	41312003	油管固定架	Oil pipe fixer	1

B. 上轴部件/Upper shaft mechanism

序号 REF. NO.	件号 Part NO.	名称	Description	数量 Qty
1	40602028	上轴	Upper shaft	1
2	B04002	轴承 6302ZZNR	Ball bearing, 6302ZZNR	1
3	B01008	轴承, 6302ZZ	Ball bearing, 6303ZZ	2
4	H01004	卡簧 42	Retaining ring, C42	1
5	40628008	隔离片	Brearing spacer	1
6	40612002	轴承盖	Brearing presser	1
7	402S11023	螺钉	Screw	3
8	40608001	轴环	Upper shaft collar	1
9	406S11016	螺钉 SM3/8×32	Screw SM3/8×32	1
10	40601001	油盒	Oil tank	1
11	40611001	油窗	Oil gauge window	1
12	10122019	油窗 O 型圈	Oil gauge window O ring	1
13	40612003	油窗盖	Oil gauge cover	1
14	401S11003	螺钉	Screw	4
15	406S11001	加油螺钉	Oil feeding pipe cap	1
16	40622004	垫片	Oil tank packing	1
17	001031	O 型圈 5×1.8	O ring 5×1.8	1

C. 针杆部件/Needle bar mechanism

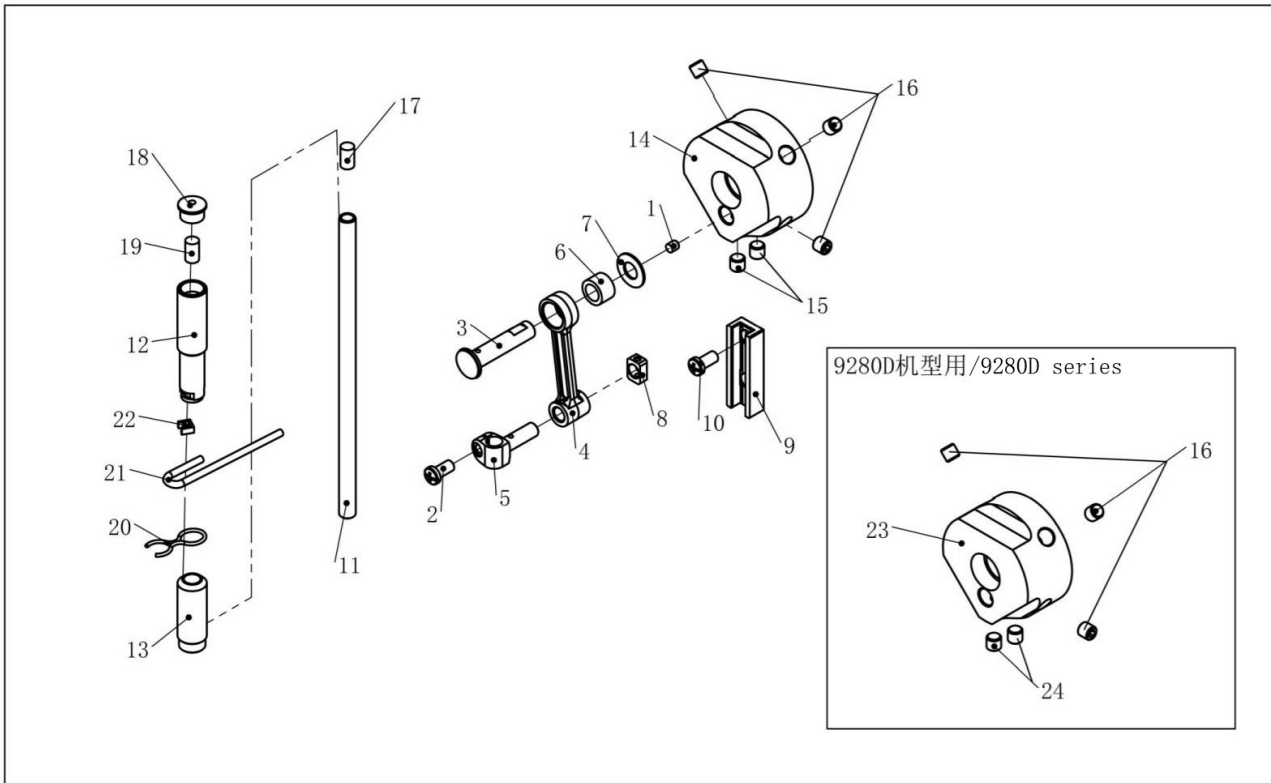

D1. 抬压脚部件 (9270D) /Presser bar mechanism(9270D)

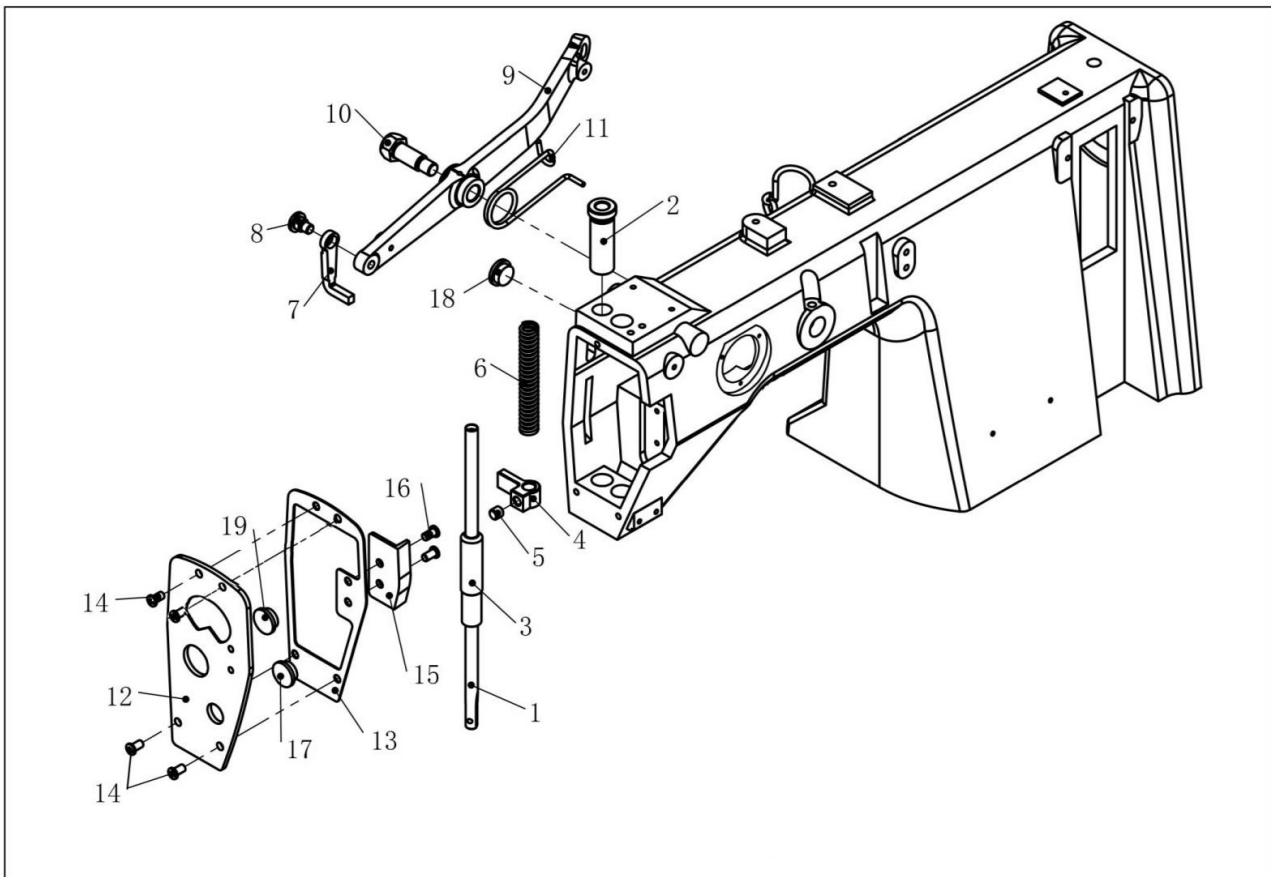

C. 针杆部件/Needle bar mechanism

序号 REF. NO.	件号 Part NO.	名称	Description	数量 Qty
1	40622005	防震橡胶垫	Rubber cap, 4. 2	1
2	101S11005	螺钉	Screw, SM3. 57	1
3	40626001	挑线连杆销	Thread take-up lever pin	1
4	40605002	挑线连杆	Thread take-up lever	1
5	40626002	针杆连接轴	Needle bar connecting shaft	1
6	10124001	挑线杆滚针轴承	Upper thread take-up needle bearing	1
7	10112003	针杆曲柄护板	Washer	1
8	40609001	针杆滑块	Needle bar guide slide block	1
9	40601002	针杆滑块座	Needle bar guide	1
10	201S11009	螺钉	Screw, pan SM3. 57-40×6	2
11	40602009	针杆	Needle bar	1
12	40603002	针杆上套	Needle bar bush, U	1
13	40603003	针杆下套	Needle bar bush, D	1
14	40604001	针杆曲柄	Thread take-up crank, MH	1
15	409S14001	螺钉	Screw, SM6. 35	2
16	116S14005	螺钉	Screw, SM6. 35	3
17	40622006	橡皮塞	Needle bar cork	1
18	40622014	油封	Oil cup	1
19	10123002	针杆上毡塞	Clutch felt	1
20	10127015	回油毡夹	Wick nipper	1
21	12923018	油线 4×4(进口)	Oil line	1
22	10112053	油线夹	Oil wick nipper	1
23	40604003	针杆曲柄	Thread take-up crank, H	1
24	409S14003	螺钉	Set screw, (CP) SM6. 35	2

D1. 抬压脚部件 (9270D) /Presser bar mechanism(9270D)

序号 REF. NO.	件号 Part NO.	名称	Description	数量 Qty
1	40602002	压脚轴	Presser bar	1
2	406S30002	压力调节螺钉	Adjust screw	1
3	40603004	压脚轴套	Adjust screw bar	1
4	40609002	压杆导架	Adjust screw bar clamp	1
5	136S14002	螺钉	Screw(import)	1
6	40627001	弹簧	Spring	1
7	40612004	抬压脚架	Presser bar lifter	1
8	406S20001	轴位螺钉	Shoulder screw, SM5. 95	1
9	300258	抬压脚杠杆	Knee lifter lever	1
10	406S20002	杠杆螺钉	Shoulder screw, SM7. 94	1
11	40627002	抬压脚架弹簧	Twist spring	1
12	300259	面板	Pace plate	1
13	40622007	面板垫	Packing	1
14	406S11009	螺钉	Screw, pan SM4. 37-40×10	4
15	40611002	挡板	Front lid	1
16	101S11007	右线勾螺钉	Screw	2
17	40122017	橡皮塞	Rubber cap	1
18	40122005	橡皮塞	Rubber cap	1
19	40122017	橡皮塞	Rubber cap	1

D2. 抬压脚部件 (9280D) /Presser bar mechanism(9280D)

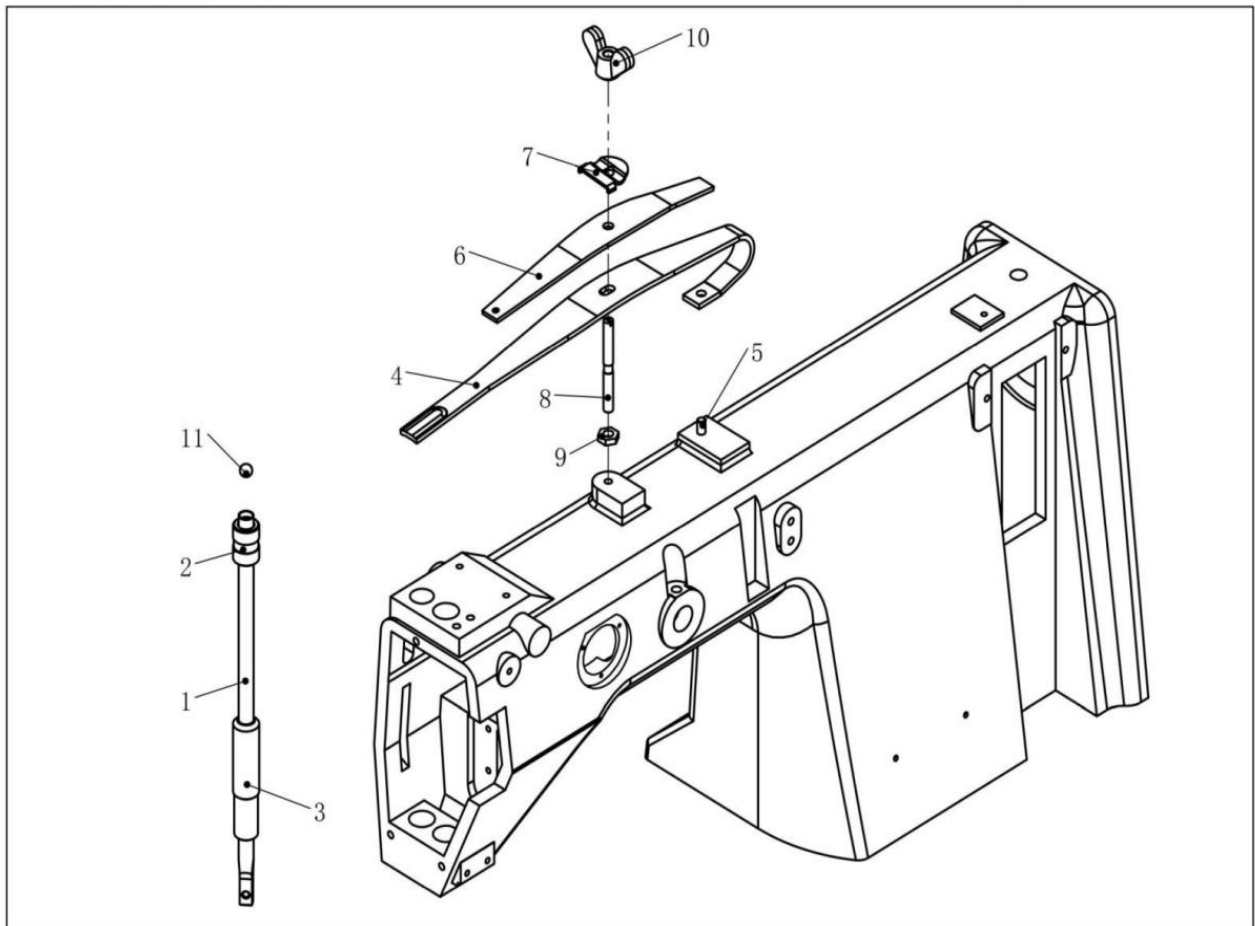

E. 带轮部件/Pulley mechanism

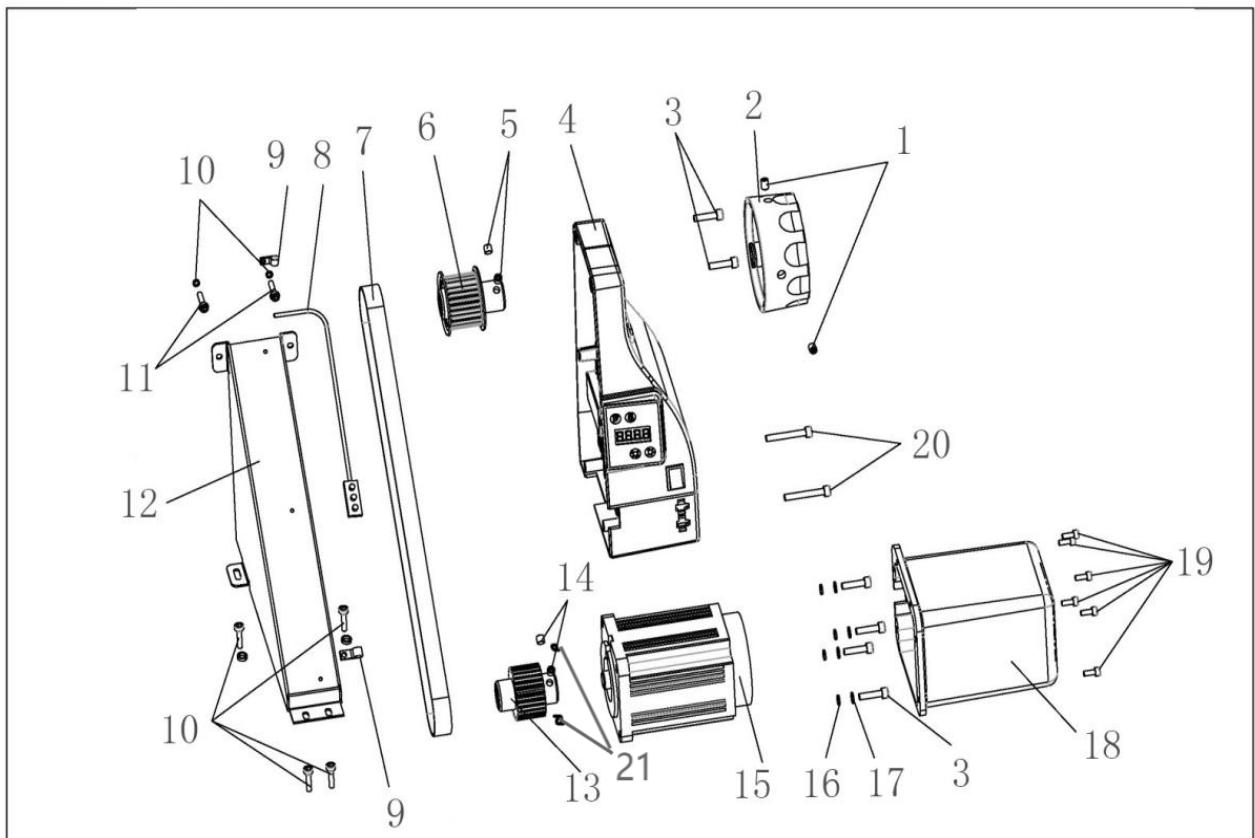

D2. 抬压脚部件 (9280D) /Presser bar mechanism(9280D)

序号 REF. NO.	件号 Part NO.	名称	Description	数量 Qty
1	40602003	压脚轴	Presser bar	1
2	40603005	压脚轴上套	Presser bar bush, U	1
3	40603006	压脚轴下套	Presser bar bush, D	1
4	40612006	弹簧片	Presser plate sping	1
5	40626003	销子	Pin	1
6	40612007	压板	Plate spring assy	1
7	40612008	垫片	Washer	1
8	406S30003	螺钉	Adjust screw	1
9	116S16006	螺母	Nut, 2 SM4.76	1
10	406S16001	调压螺母	Presser bar lifter	1
11	40624006	钢珠	Rubber cap, 20.5	1

E. 带轮部件/Pulley mechanism

序号 REF. NO.	件号 Part NO.	名称	Description	数量 Qty
1	403S14005	内六角平端紧定螺钉	Hexagon Socket Set Screw With Flat Point	2
2	302824	手轮	Pulley assy	1
3	114S30001	内六角螺钉 M5×25	Socket head cap screw, M5×25	6
4	40633002	一体机电控(琦星)	Integrated electronic control	1
5	409S14001	螺钉	Screw	2
6	4063502600	上轴同步带轮组件	Timing belt wheel assy, upper	1
7	40635025	传动带	Timing belt	1
8	40330025	LED 灯	LED light	1
9	12512054	齿轮供油管夹	Clamp	3
10	40928020	垫圈	Washer	4
11	207S11019	螺钉 M4×7.5	Screw, M4×7.5	6
12	303054	同步带罩壳	Belt housing	1
13	40635024	下轴同步带轮	Timing belt wheel assy, lower	1
14	116S14005	螺钉	Screw	2
15	40633003	电机	Electric motor	1
16	13628013	电机垫圈	Motor washer	4
17	W03002	波形垫片	Washer	4
18	40612079	电机罩壳	Motor casing	1
19	S05048	螺钉 M4×10	Screw, M4×10	6
20	S05083	螺钉 M5×30	Screw, M5×30	2
21	113809001	驱动曲柄顶柱	Drive crank top post	2

F. 送料部件/Feed mechanism

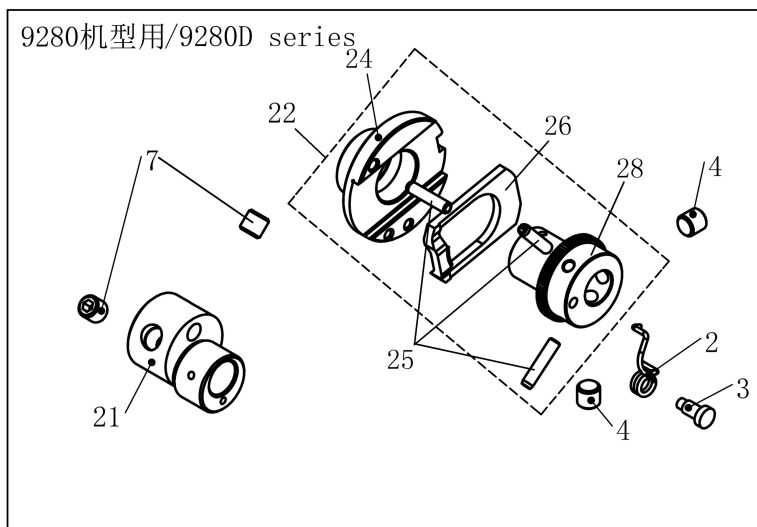
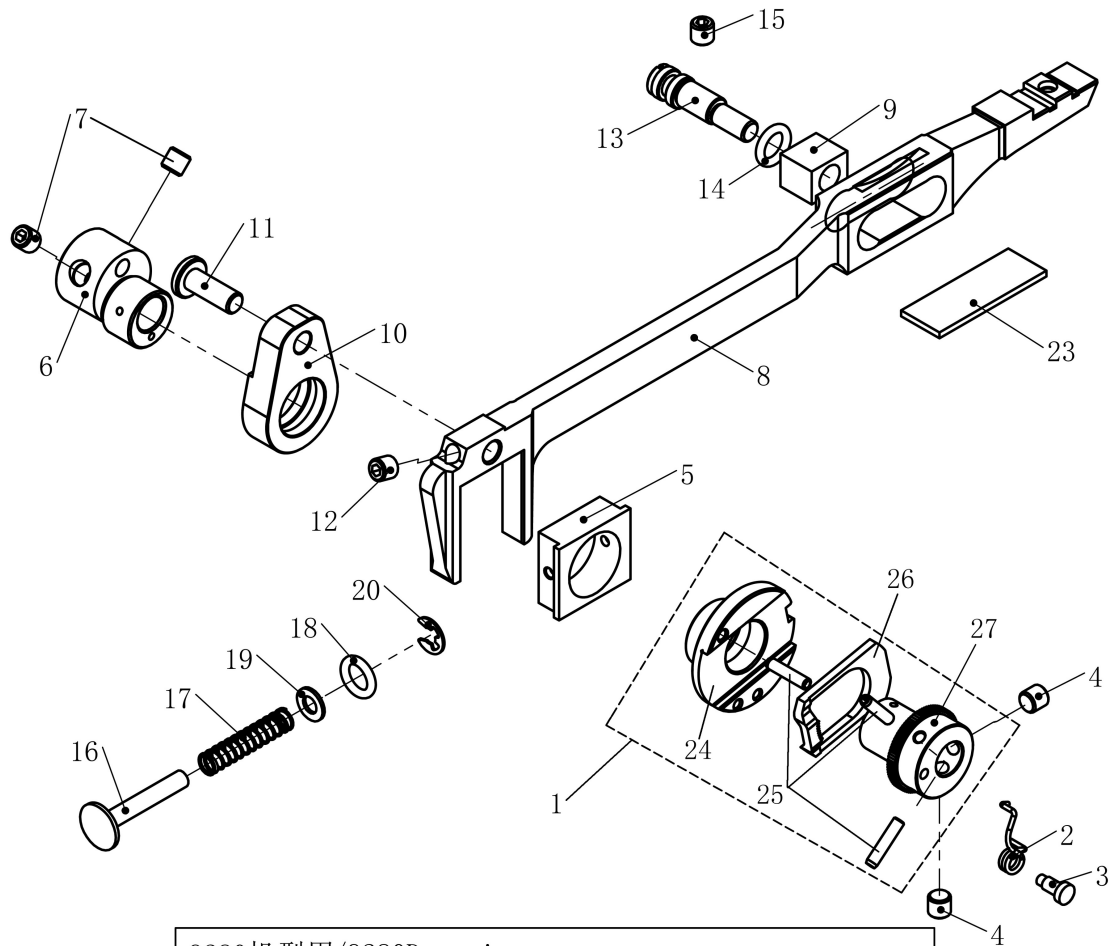

F. 送料部件/Feed mechanism

序号 REF. NO.	件号 Part NO.	名称	Description	数量 Qty
1	4061000100	送料凸轮组件	Eccentric wheel assy, M	1
2	40627003	弹簧	Twist spring	1
3	406S20009	螺钉	Screw, M3	1
4	403s14004	螺钉	Set screw, socket M6×6	2
5	40609003	送料滑块	Eccentric wheel sleeve	1
6	40610006	送料偏心轮	Eccentric wheel with screw, M	1
7	403S14004	螺钉	Set screw, socket SM6. 35	2
8	40606001	送料牙架	Feed bar slide block assy	1
9	40609004	牙架滑块	Feed bar slider	1
10	40604004	送料曲柄	Feed lifting connencting shaft	1
11	40626004	曲柄销	Feed lifting rock shaft	1
12	409S15002	螺钉	Set screw, socket SM5. 95	1
13	40626005	送料偏心销	Feed bar eccentrics shaft	1
14	001016	O型圈6×1.8	O ring, 6×1.8	1
15	409S15002	左销螺钉	Set screw, socket (cp) SM5. 95	1
16	40626006	针距调节销	Push button	1
17	40627004	弹簧	Spring	1
18	001004	O型圈4×1.8	O ring, 4×1.8	1
19	42128020	垫圈	Washer, plain S4. 76	1
20	H05012	挡圈	Retaining ring, E4	1
21	40610007	送料偏心轮	Eccentric wheel with screw, H	1
22	4061001100	送布凸轮组件	Eccentric wheel assy, H	1
23	40123008	油隔热板	Oilproof wool felf	1
24	40610003	针距调节凸轮	Needle adjustment cam	1
25	40626035	弹簧销	Spring pin	1
26	40625001	止动板	Stop plate	1
27	40610002	止动凸轮	Stop cam	1
28	40610014	止动凸轮	Stop cam	1

G1. 零件关系/Gauge parts (9270D Standard)

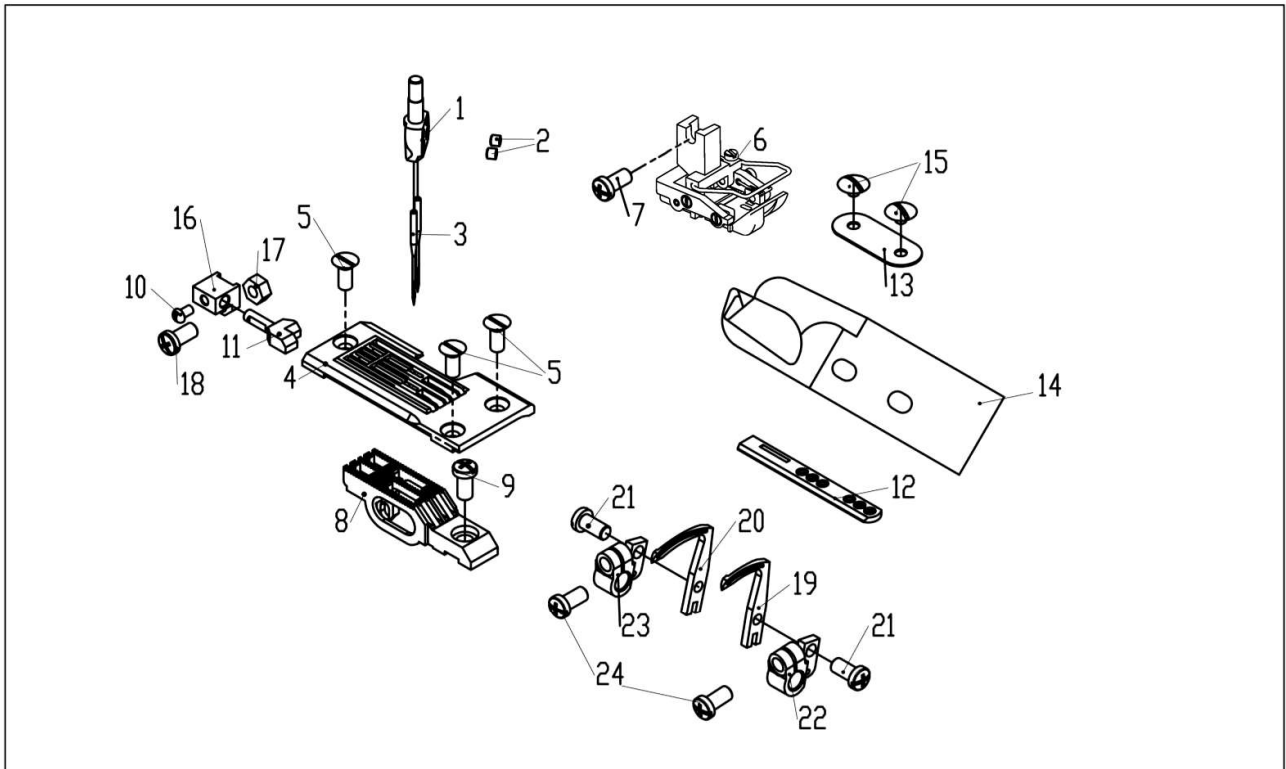

G2. 零件关系/Gauge parts (9280D Standard)

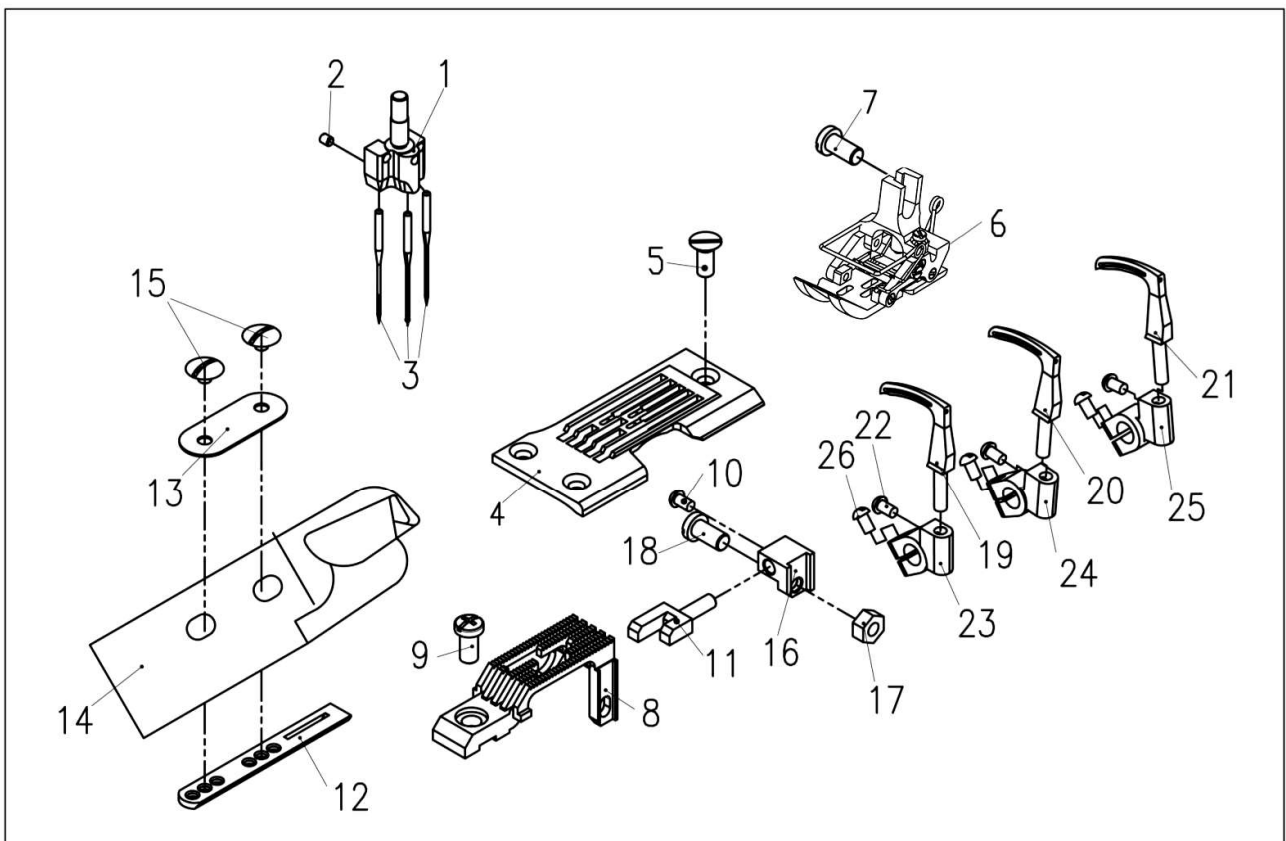

G1. 零件关系/Gauge parts (9270D Standard)

序号 REF. NO.	件号 Part NO.	名称	Description	数量 Qty
1	40634002	针夹头	Needle calmp assy w/s	1
2	125S15007	支针螺钉	Screw	2
3	40617001	TV×64 12#机针	Needle	2
4	40615002	针板	Needle plate	1
5	101S17002	针板螺钉	Screw, flat SM4. 37	3
6	4061600200	压脚组件	Presser foot assy, 1/4"	1
7	101S11009	活压脚螺钉	Screw, bind SM3. 57-40×8	1
8	40614002	送料牙齿	Feed dog	1
9	402S11023	螺钉	Spring	1
10	----	护针固定螺钉	Screw, SM2. 38	1
11	40617008	护针	Needle guard	1
12	40609005	滑块	Lapper guide plate	1
13	40612011	安装板	Lapper guide plate washer	1
14	40612011	卷边器	Lapper assy	1
15	406S11002	安装板螺钉	Screw	2
16	40604007	护针架	Needle guard bracket	1
17	----	螺母	Needle guard	1
18	----	螺钉	Lapper guide plate	1
19	40617011	前弯针	Lopper, S	1
20	40617017	后弯针	Looper, L	1
21	101S11007	螺钉	Screw, SM3. 57	2
22	4060400500	前弯针架	Looper holder ,S	1
23	4060400600	后弯针架	Looper holder ,L	1
24	----	螺钉	Lopper, S	2

G2. 零件关系/Gauge parts (9280D Standard)

序号 REF. NO.	件号 Part NO.	名称	Description	数量 Qty
1	40634007	针夹头	Needle calmpassy w/s	1
2	125S15007	支针螺钉	Screw	2
3	40617005	TV×5 21#机针	Needle	2
4	40615011	针板	Needle plate	1
5	101S17002	针板螺钉	Screw, flat SM4. 37	3
6	40616010	压脚组件	Presser foot assy, 1/4"	1
7	101S11009	活压脚螺钉	Screw, bind SM3. 57-40×8	1
8	40614007	送料牙齿	Feed dog	1
9	402S11023	螺钉	Spring	1
10	----	护针固定螺钉	Screw, SM2. 38	1
11	40617021	护针	Needle guard	1
12	40609005	滑块	Lapper guide plate	1
13	40612011	安装板	Lapper guide plate washer	1
14	4061502700	卷边器	Lapper assy	1
15	406S11002	安装板螺钉	Screw	2
16	40604007	护针架	Needle guard bracket	1
17	----	螺母	Needle guard	1
18	----	螺钉	Lapper guide plate	1
19	40617013	前弯针	Lopper, S	1
20	40617015	中弯针	Looper, M	1
21	40617019	后弯针	Looper, L	1
22	301S11023	螺钉	Screw, SM3. 57	3
23	40604010	弯针架 (右)	Looper holder ,M	1
24	40604008	弯针架 (中)	Looper holder ,S	1
25	40604009	弯针架 (左)	Looper holder ,L	1
26	413S13031	螺钉9/64×40	Screw, SM9/64×40	3

J. 下轴部件/Lower shaft mechanism

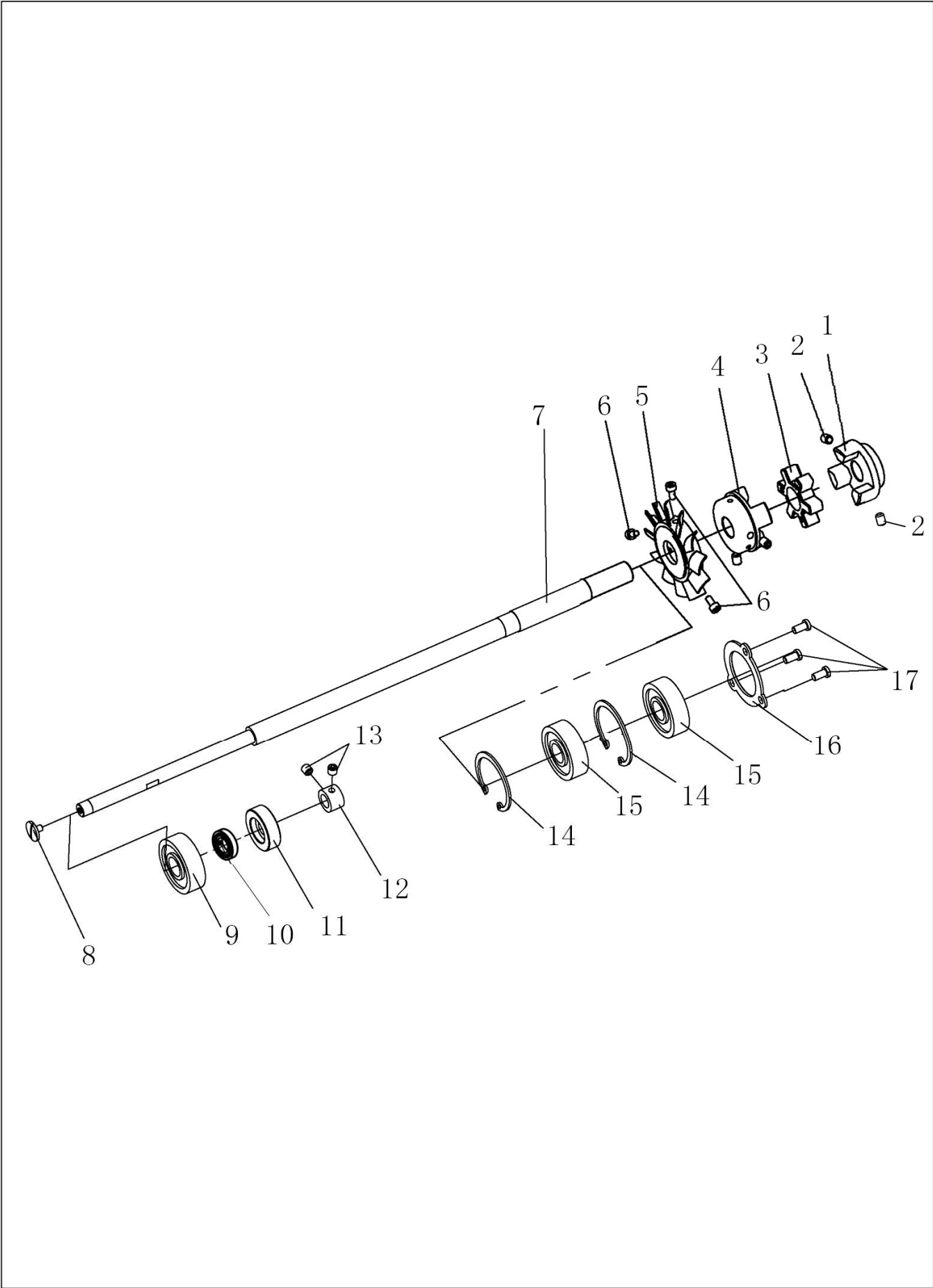

J. 下轴部件/Lower shaft mechanism

序号 REF. NO.	件号 Part NO.	名称	Description	数量 Qty
1	40601059	传动连接块 2	Drive connecting block 2	1
2	403S14005	内六角平端紧定螺钉	Set Screw Socket (FT) M6×8	4
3	40322028	减震橡胶	Shock absorbing rubber	1
4	40301023	传动连接块	Drive connecting block	1
5	40311302	叶轮	Impeller	1
6	402S11023	螺钉	Screw, pan SM4. 76-32×10	3
7	40602029	下轴	Lower shaft	1
8	101S11023	送料调节器轴端螺钉	Screw, SM4. 37	1
9	B03003	轴承6200Z	Ball bearing, 6200Z	1
10	20622019	油封	Oil seal	1
11	40608005	轴套	Shaft sleeve	1
12	40608002	下轴挡圈	Lower shaft collar	1
13	409S14002	挡圈螺钉	Set screw, SM4. 37	2
14	H01004	卡簧42	Retaining ring, C42	2
15	B01008	轴承 6302ZZ	Ball bearing, 6320ZZ	2
16	40612002	轴承盖	Bearing presser	1
17	402S11023	螺钉	Screw, pan SM4. 76-32×10	3

K. 弯针轴部件/Looper mechanism

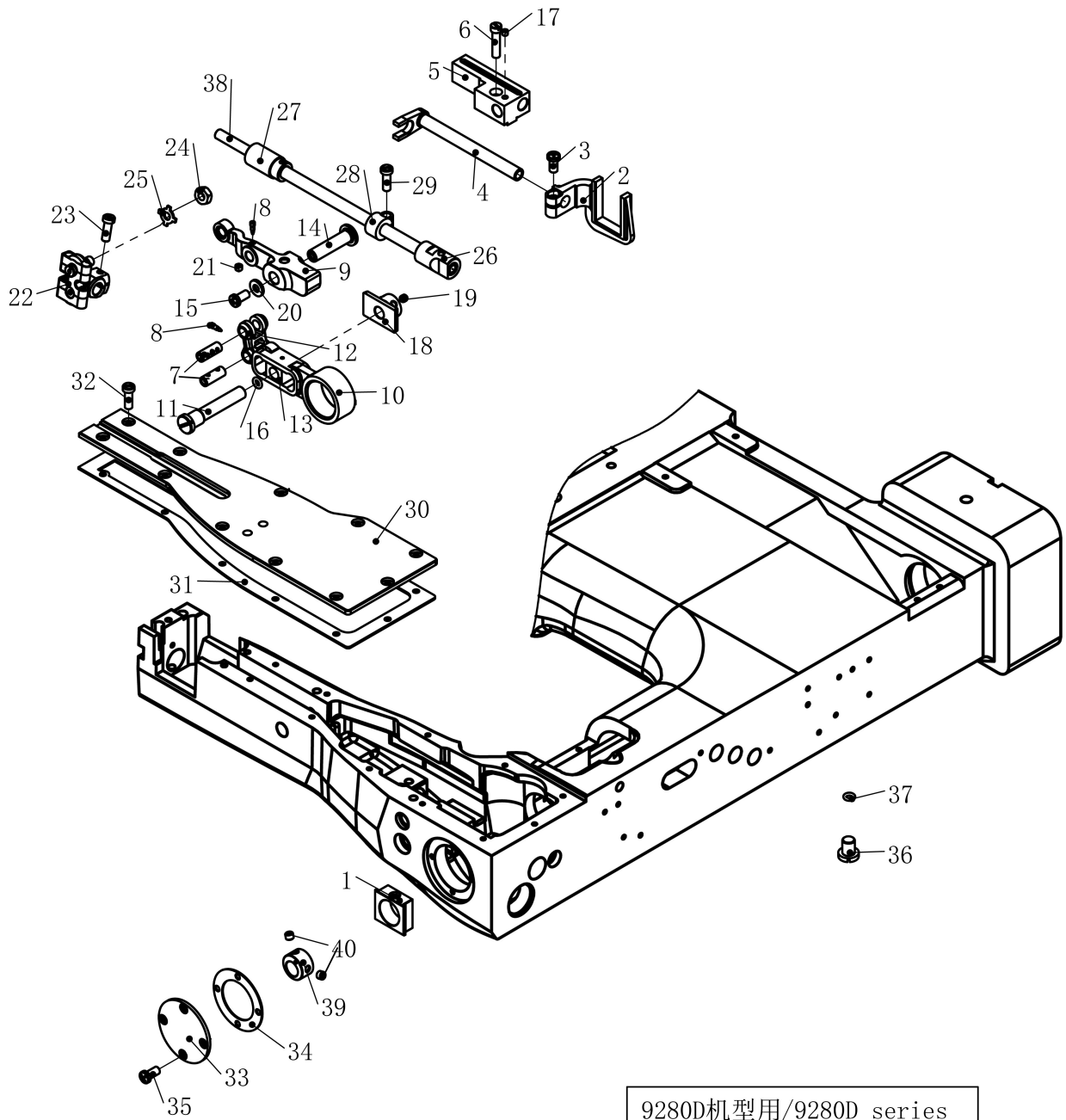

9280D机型用/9280D series

40
41

K. 弯针轴部件/Looper mechanism

序号 REF. NO.	件号 Part NO.	名称	Description	数量 Qty
1	400138	离合滑块	Eccentric wheel sleeve	1
2	40605003	弯针离合叉	Looper feeding fork assy	1
3	201S11023	螺钉	Screw, SM4. 37	1
4	40602005	弯针离合轴	Looper feeding fork shaft	1
5	40601006	弯针离合轴座	Looper fork shaft bracket	1
6	406S30013	螺钉	Screw, SM4. 76	1
7	40626022	曲柄连接销	Looper link shaft	2
8	406S30004	螺钉	Screw, SM2. 38	2
9	40604012	离合曲柄	Looper lever	2
10	40604019	离合架	Looper holder	1
11	40626009	销子	Pin	1
12	40605004	曲柄	Lever	1
13	40609010	曲柄滑块	Lever slider	1
14	40626010	销子	Pin	1
15	406S11004	螺钉	Screw, SM4. 37	1
16	001016	O 型圈 6×1.8	O ring 6×1.8	1
17	135S15008	螺钉	Set screw, SM5. 95	1
18	40608003	离合架销挡圈	Block plate	1
19	409S14002	内六角平端紧定螺钉	Set Screw Socket (FT) M6×8	2
20	001004	O 型圈 4×1.8	O ring 4×1.8	1
21	402S14006	螺钉	Screw, SM5. 95	1
22	4060401500	弯针摆杆	Looper shaft link assy set	1
23	201S11023	螺钉	Set screw	1
24	409S16020	螺母	Nut, SM5. 95	1
25	W03026	波形垫片 5.8	Washer	1
26	40603007	弯针轴后套	Looper shaft bush, F	1
27	40603008	弯针轴前套	Looper shaft bush, B	1
28	40608004	挡圈	Looper shaft set collar	1
29	201S11023	螺钉	Screw, pan SM4. 37-40×8	1
30	40612012	下仓盖	Front feed arm cap	1
31	40622010	下仓盖垫	Packing	1
32	101s11009	活压脚螺钉	Screw, SM3. 57	1
33	300263	下轴前盖	Ball bearing	1
34	40622011	垫片	Packing	1
35	401S11003	螺钉	Screw, pan SM3. 57-40×5	4
36	207S13002	放油螺钉	Screw	2
37	40222027	给油帽衬垫	O ring	1
38	40602006	弯针轴	Looper shaft	1
39	40610008	抬牙偏心轮	Eccentric wheel	1
40	409S14002	内六角平端紧定螺钉	Set Screw Socket (FT) M6×8	2
41	40610009	抬牙偏心轮	Eccentric wheel	1

L1. 上线过线部件 (9270D) Lower shaft mechanism

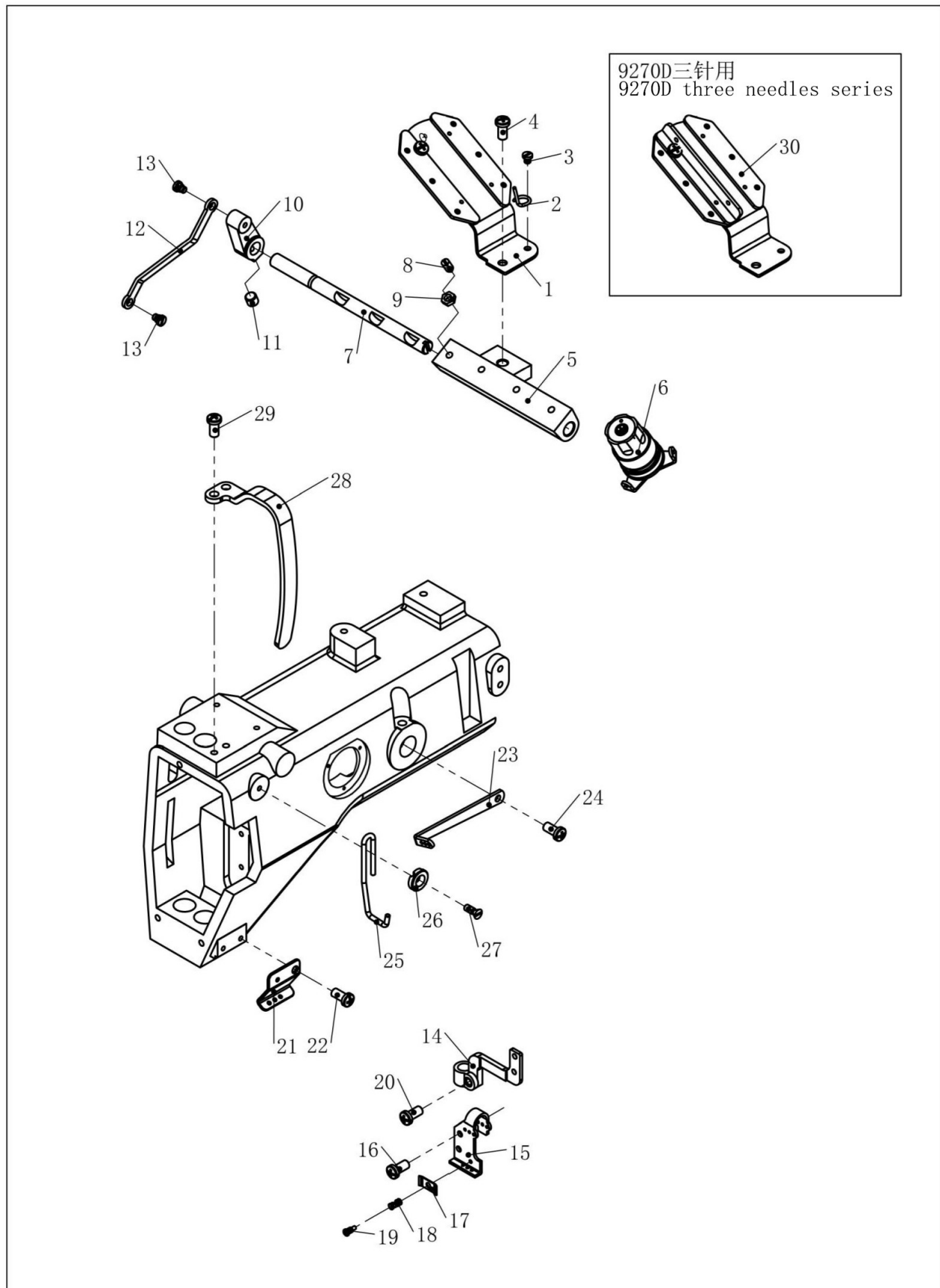

L1. 上线过线部件 (9270D) Lower shaft mechanism

序号 REF. NO.	件号 Part NO.	名称	Description	数量 Qty
1	4061201400	面线导线支架板	Upper thread guide	1
2	40613001	过线勾	Thread guide	1
3	402S11022	螺钉	Screw	1
4	406S11018	螺钉 SM3/16×28	Screw, SM3/16×28	1
5	300264	面线松线器座	Upper thread tension bracket	1
6	4061304000	夹线器组件	yarn trapper assy	1
7	40602007	松线轴	Tension release shaft	2
8	406S30007	螺钉	Set screw, SM4. 37	2
9	201S16003	螺母	Nut, SM4. 37	1
10	40604016	松线曲柄	Tension release crank	1
11	201S14002	螺钉	Set screw, SM4. 37	1
12	40612015	连接板	Tension release connecting rod	1
13	406S20007	螺钉	Shoulder screw, SM3. 57	1
14	40605005	挑线杆部件	Upper thread take-up assy	1
15	40613002	挑线过线板	Upper thread guide	1
16	406S11015	螺钉	Screw, pan SM3. 18×5	2
17	40613003	过线压板	Upper thread take-up holder	1
18	20727002	压簧	Spring	1
19	207S20003	螺钉(进口)	Screw (import)	2
20	125S11003	牙架销螺钉	Screw	1
21	40613004	过线板	Upper thread guide	1
22	201S11009	螺钉	Screw, pan SM3. 57-40×7	1
23	40613005	张力缓线勾	Tension release lever	1
24	201S11009	螺钉	Screw	1
25	40613006	挑线过线架	Upper thread thake-up guide	1
26	40628003	垫片	Washer	1
27	406S30005	螺钉	Screw, flat SM3. 57	1
28	300268	防护罩	Thread take-up cover	1
29	406S11009	螺钉	Screw pan SM4. 76-32×8	2
30	4061204400	面线导线支架板组件	Upper thread guide assy	1

L2. 上线过线部件 (9280D) /Upper threading mechanism(9280D)

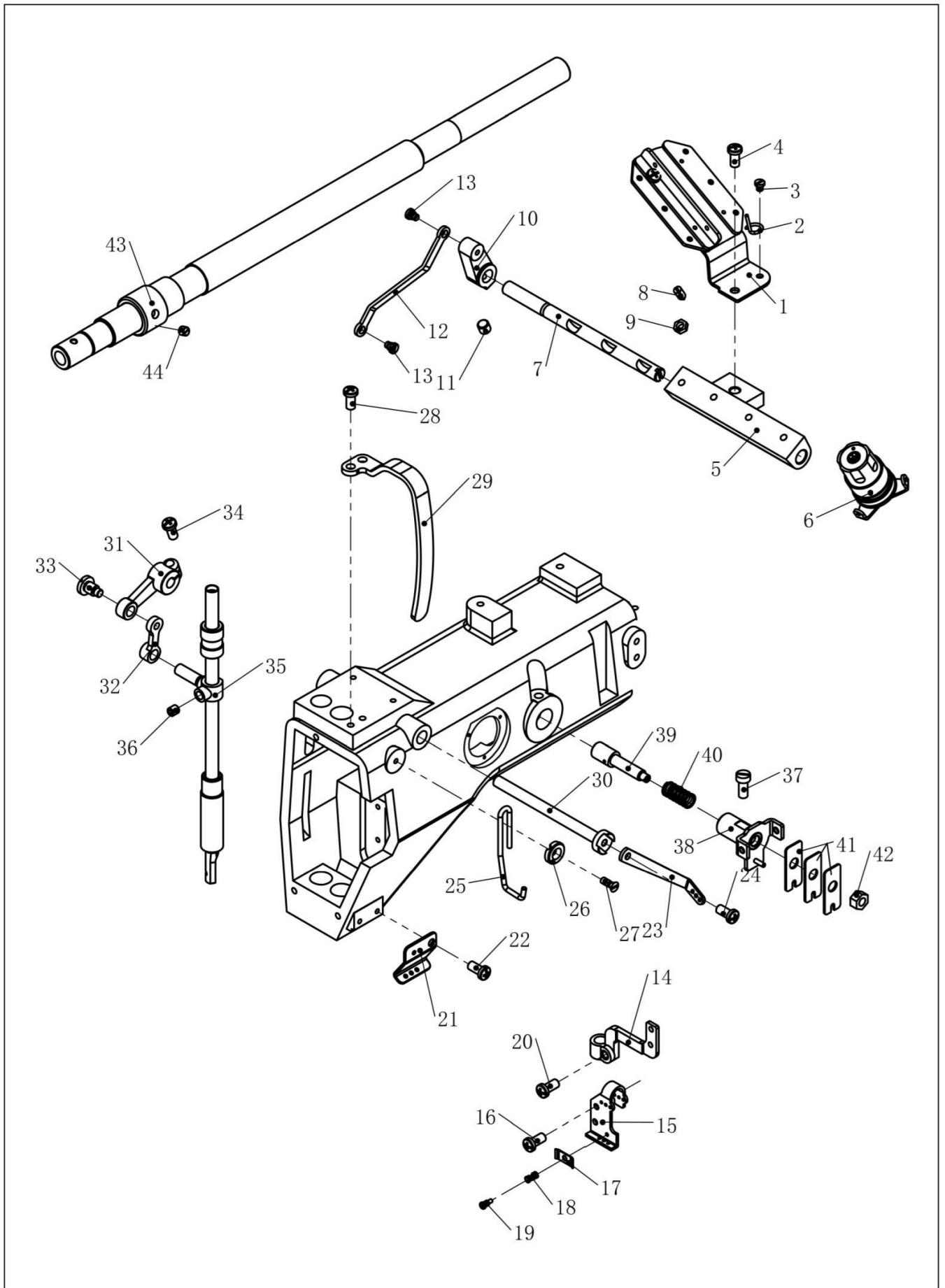

L2. 上线过线部件 (9280D) /Upper threading mechanism(9280D)

序号 REF. NO.	件号 Part NO.	名称	Description	数量 Qty
1	4061204400	面线导线架支架板	Upper thread guide	1
2	40613001	过线勾	Thread guide	1
3	402S11022	螺钉	Screw, pan SM3. 57-40×5	1
4	406S11018	螺钉 SM3/16×28	Screw, SM3/16×28	1
5	300264	面线松线器座	Upper thread tension bracket	1
6	4061304000	夹线器组件	yarn trapper assy	2
7	40602007	松线轴	Tension release shaft	1
8	406S30007	螺钉	Set screw, SM4. 37	1
9	201S16003	螺母	Nut, SM4. 37	1
10	40604016	松线曲柄	Tension release crank	1
11	201S14002	螺钉	Set screw, SM4. 37	1
12	40612015	连接板	Tension release connecting rod	1
13	406S20007	螺钉	Shoulder screw, SM3. 57	2
14	40605005	挑线杆部件	Upper thread take-up assy	1
15	40613002	挑线过线板	Upper thread guide	1
16	406S11015	螺钉	Screw, pan SM3. 18×5	2
17	40613003	过线压板	Upper thread take-up holder	1
18	20727002	压簧	Spring	1
19	207S20003	螺钉(进口)	Screw (import)	1
20	125S11003	牙架销螺钉	Screw	1
21	40613004	过线板	Upper thread guide	1
22	201S11009	螺钉	Screw pan SM3. 57-40×7	1
23	40613005	张力缓线勾	Tension release lever	1
24	201S11009	螺钉	Screw, bind SM3. 57-40×8	1
25	40613006	挑线过线架	Upper thread take-up guide	1
26	40628003	垫片	Washer	1
27	406S30005	螺钉	Screw, flat SM3. 57	1
28	105S11015	螺钉	Screw, pan SM4. 76-32×8	1
29	300268	防护罩	Thread take-up cover	1
30	40602008	打线传动轴	T/release transmission shaft	1
31	40604017	打线曲柄	T/release connecting rod assy	1
32	40605006	连杆	Tension release link	1
33	406S20008	压脚升降连杆螺钉	Shoulder screw SM4. 76	1
34	301S11007	挡圈螺钉	Screw, SM3. 57	1
35	40626012	连接柱	Tension release stud	1
36	136S14002	螺钉	Screw (import)	1
37	401S11009	螺钉	Screw	1
38	40612020	压线板座	Upper therad tension bracket	1
39	40626013	松线轴	Upper thread stup assy	1
40	40627008	弹簧	Spring	1
41	40613011	压线板	Lower thread tension plate	1
42	-----	螺母	Nut	1
43	40610010	松线偏心套	Upper thread cam	1
44	136S14002	螺钉	Screw (import)	2

M1. 下线过线部件 (9270D) /Lower threading mechanism (9270D)

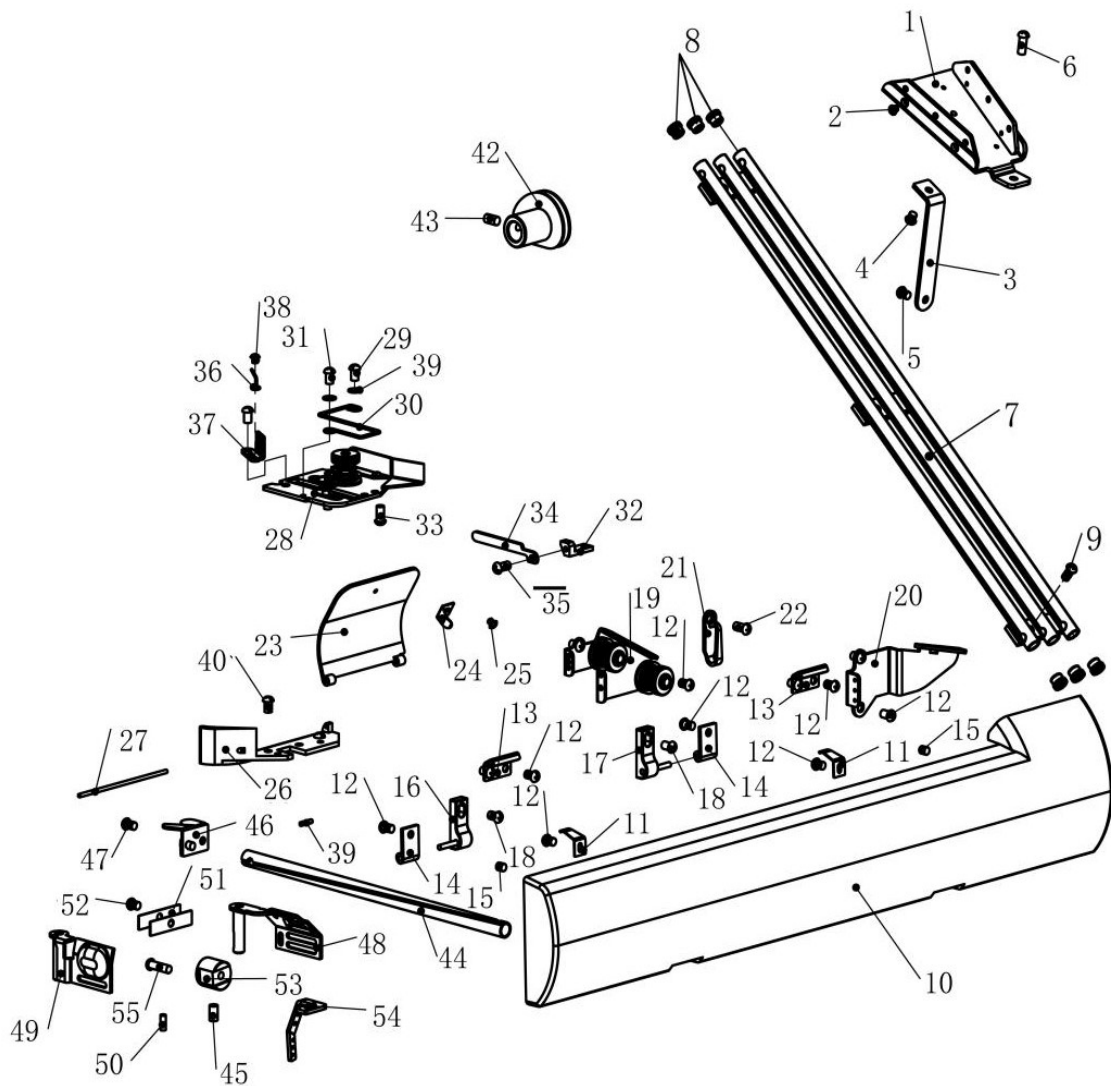

9280-2PL用
9280-2PL series

57

9270D三针用
9270D three needles series

56

M1. 下线过线部件 (9270D) /Lower threading mechanism (9270D)

序号 REF. NO.	件号 Part NO.	名称	Description	数量 Qty
1	4061202100	底线导线安装板	Lower thread guide retainer	1
2	101S11019	推板簧螺钉	Screw, flat SM2. 38	4
3	40602021	支撑板	Lower thread guide support	1
4	402S11002	螺钉	Screw, pan SM3. 57-40×4	1
5	206S11002	螺钉	Screw, pan SM3. 57-40×5	1
6	206S11002	螺钉	Screw, pan SM3. 57-40×10	1
7	302825	过线管组件	Inglide guide tube assy	1
8	40613029	过线管塞	Crossed the line pipe plug	6
9	201S11009	螺钉	Screw, pan SM3. 57-40×8	3
10	300266	底线外盖	Front cover	1
11	40627012	底线外盖卡簧	Front cover spring	1
12	201S11009	开槽圆柱头螺钉	Screw, pan SM3. 57-40×5.5	9
13	40612022	盖板固定板	Front conver hook	1
14	40612023	转动架	Hinge	2
15	40622005	防震橡胶垫	Rubber cap, 4.2	2
16	40601009	左转动架	Thread guide hinge assy, L	1
17	40601010	右转动架	Thread guide hinge assy, R	1
18	101S11009	活压脚螺钉	Screw, pan SM3. 57-40×6	2
19	4061301200	夹线器安装板	Lower thread guide	1
20	4061301300	过线板	Lower thread guide	1
21	40613032	大线钩	Arm thread guide M	1
22	116S17002	线勾螺钉	Screw, flat SM3. 57	1
23	300267	打线凸轮盖	Thread take-up lever cover	1
24	40627009	卡簧	Spring, plate	1
25	101S11019	推板簧螺钉	Screw, SM2. 38	1
26	40601011	底线转向过线板	Take-up lever bracket	1
27	40626015	打线凸轮盖销	Take-up lever cov. shaft	1
28	4061202500	凸轮导线架	Take-up lever bracket	1
29	101S11005	螺钉	Screw, pan SM3. 57-40×6	2
30	40627010	导线钢丝	Lower thread guide	1
31	201S11033	螺钉	Screw, bind SM3. 18-40×4	1
32	40609007	底线打线架	Thread release base	1
33	201S11005	开槽圆柱头螺钉	Scerw, pan SM3. 18-40×4	2
34	40612027	底线打线板	Lower thread presser	1
35	406S11015	螺钉	Scerw, pan SM3. 18-40×4	1
36	40613017	压线钢丝	Thread guide	1
37	140613002	底线导线板	Lower thread guide plate	1
38	209S11007	辅助爪螺钉	Screw, SM2. 38	1
39	40928021	垫圈	Washer	2
40	P03014	销 5×12.5	Pin spring roll AW5	1
41	301S11007	挡圈螺钉	Screw, SM3. 57	2
42	140613003	打线凸轮	Lower thread take-up W/S, M	1
43	409S14002	内六角平端紧定螺钉	Set Screw Socket (FT) M6×8	2

M1. 下线过线部件 (9270D) / Lower threading mechanism (9270D)

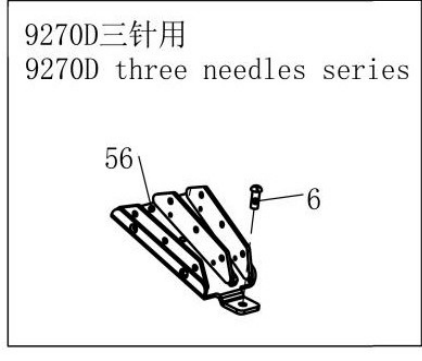
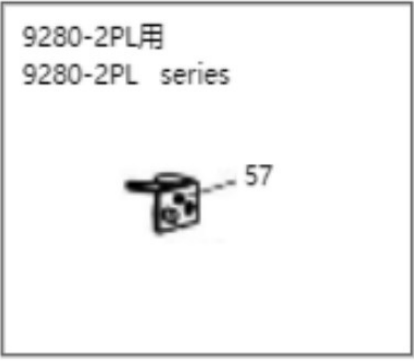
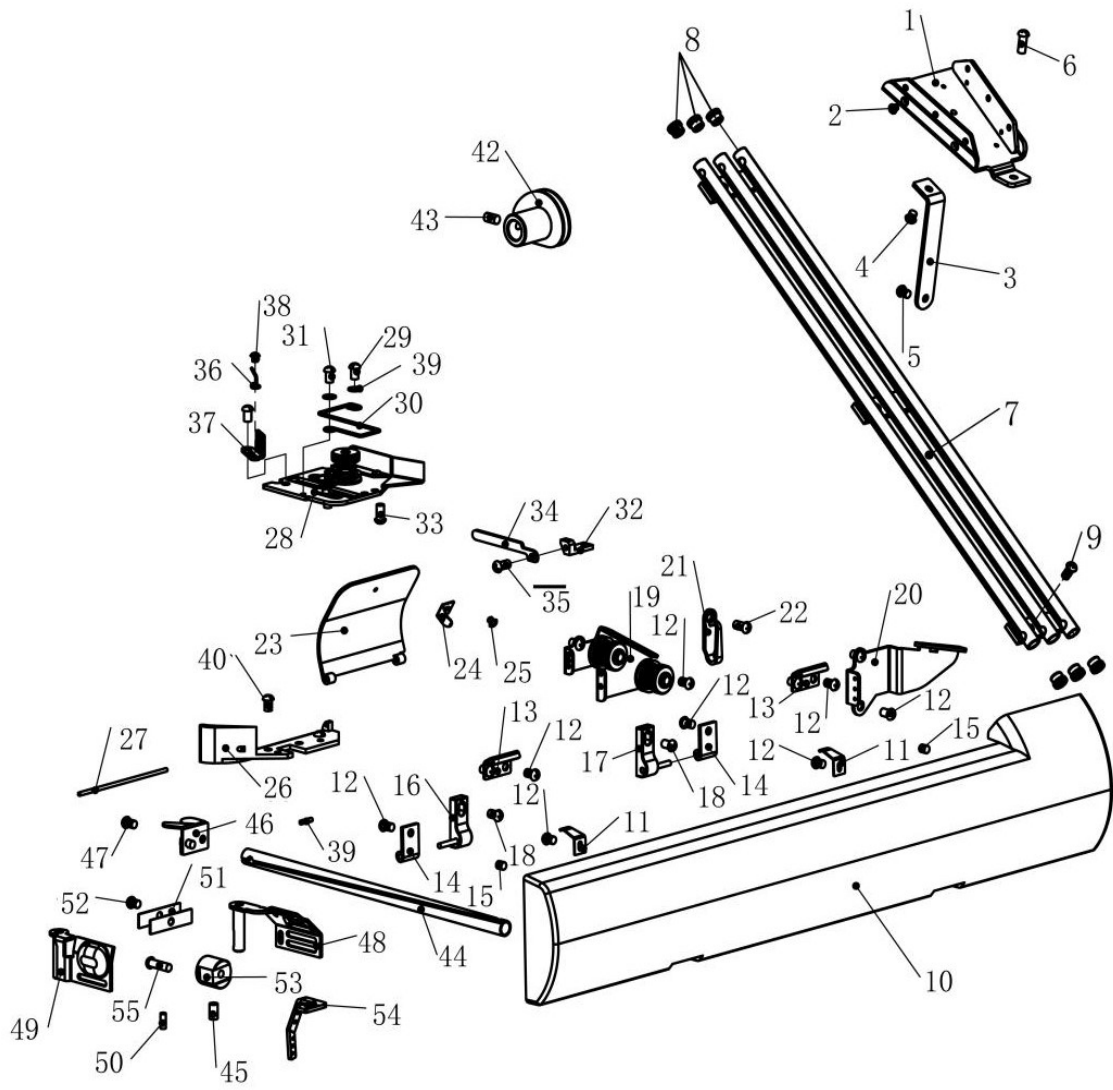

44	40613020	底线过线管	Lower thread feed bar guide	1
45	409S15004	螺钉	Set screw, SM5. 95	1
46	40619005	切线刀	Thread trimmer guide plate	1
47	403S11017	复合槽圆柱头螺钉	Screw , pan SM3. 57	1
48	40612028	右弯针盖	Looper cover, RA	1
49	40612029	左弯针盖	Looper cover, LA	1
50	P03015	销 2×8.5	Pin2×8.5	1
51	40612030	弯针盖压板	Spring	2
52	201S11009	螺钉	Screw, pan SM3. 57-40×7	1
53	40601012	护针支架	Looper thread guide bracket	1
54	40613024	导线架	Looper thread guide	1
55	201S11037	螺钉	Screw, pan SM3. 57-40×14	1
56	4061204500	底线导线安装板	Lower thread guide retainer	1
57	140619001	剪线刀	Thread trimmer guide plate	1

M2. 下线过线部件 (9280D) / Lower threading mechanism (9280D)

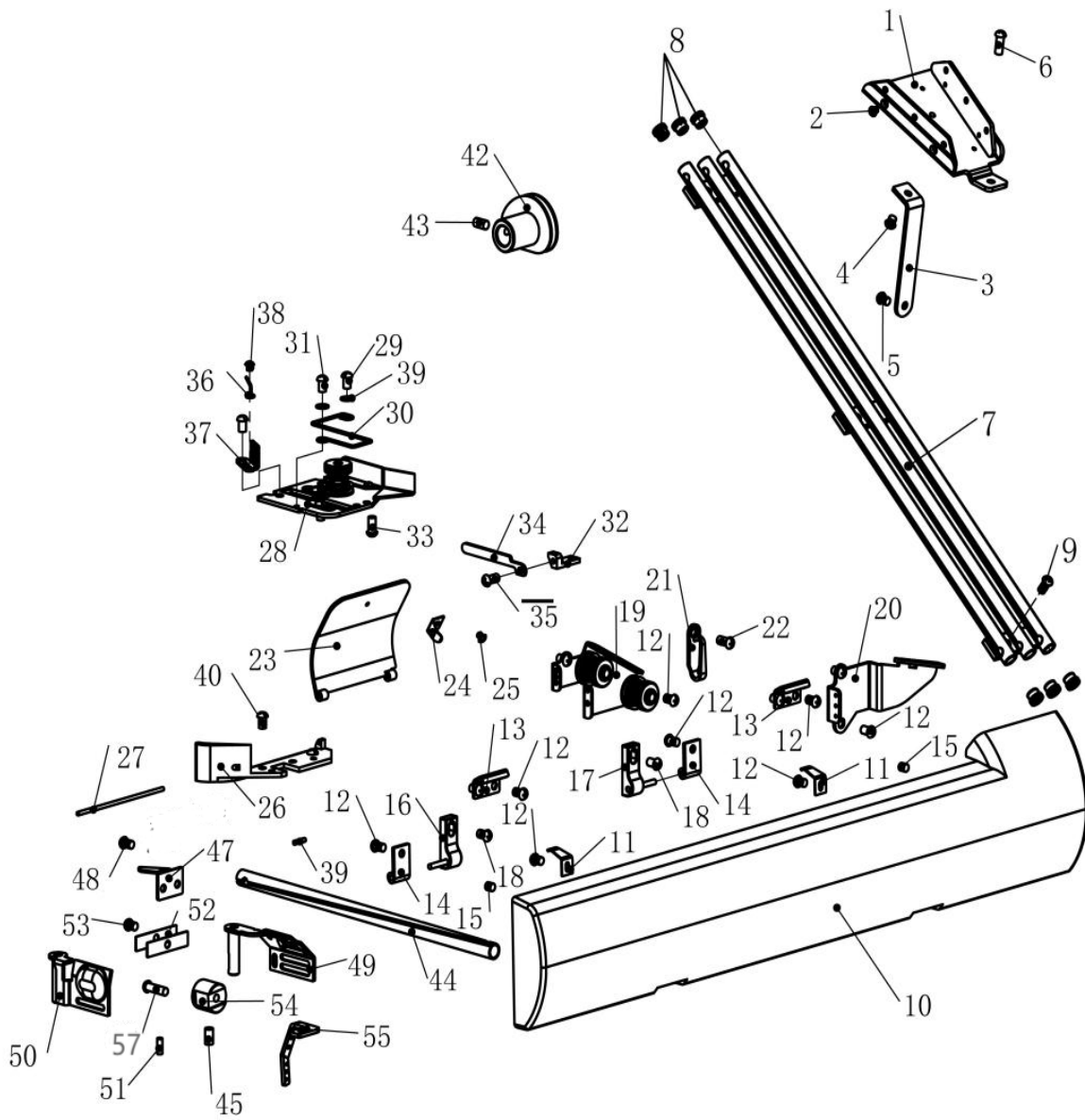

9280-2PL用
9280-2PL series



M2. 下线过线部件 (9280D) /Lower threading mechanism (9280D)

序号 REF. NO.	件号 Part NO.	名称	Description	数量 Qty
1	4061202100	底线导线安装板	Lower thread guide retainer	1
2	101S11019	推板簧螺钉	Screw, flat SM2. 38	4
3	40602021	支撑板	Lower thread guide support	1
4	402S11002	螺钉	Screw, pan SM3. 57-40×4	1
5	206S11002	螺钉	Screw, pan SM3. 57-40×5	1
6	206S11002	螺钉	Screw, pan SM3. 57-40×10	1
7	302825	过线管组件	Inglide guide tube assy	1
8	40613029	过线管塞	Crossed the line pipe plug	6
9	201S11009	螺钉	Screw, pan SM3. 57-40×8	3
10	300266	底线外盖	Front cover	1
11	40627012	底线外盖卡簧	Front cover spring	2
12	201S11009	开槽圆柱头螺钉	Screw, pan SM3. 57-40×5.5	12
13	40612022	盖板固定板	Front cover hook	2
14	40612023	转动架	Hinge	2
15	40622005	防震橡胶垫	Rubber cap, 4.2	2
16	40601009	左转动架	Thread guide hinge assy, L	1
17	40601010	右转动架	Thread guide hinge assy, R	1
18	101S11009	活压脚螺钉	Screw, pan SM3. 57-40×6	2
19	4061301200	夹线器安装板	Lower thread guide	1
20	4061301300	过线板	Lower thread guide	1
21	40613032	大线钩	Arm thread guide M	1
22	116S17002	线勾螺钉	Screw, flat SM3. 57	1
23	300267	打线凸轮盖	Thread take-up lever cover	1
24	40627009	卡簧	Spring, plate	1
25	101S11019	推板簧螺钉	Screw, SM2. 38	1
26	40601011	底线转向过线板	Take-up lever bracket	1
27	40626015	打线凸轮盖销	Take-up lever cov. shaft	1
28	4061202500	凸轮导线架	Take-up lever bracket	1
29	101S11005	螺钉	Screw, pan SM3. 57-40×6	2
30	40627010	导线钢丝	Lower thread guide	1
31	201S11033	螺钉	Screw, bind SM3. 18-40×4	1
32	40609007	底线打线架	Thread release base	1
33	201S11005	开槽圆柱头螺钉	Scerw, pan SM3. 18-40×4	2
34	40612027	底线打线板	Lower thread presser	1
35	406S11015	螺钉	Scerw, pan SM3. 18-40×4	1
36	40613017	压线钢丝	Thread guide	1
37	140613002	底线导线板	Lower thread guide plate	1
38	209S11007	辅助爪螺钉	Screw, SM2. 38	1
39	40928021	垫圈	Washer	2
40	P03014	销 5×12.5	Pin spring roll AW5	1
41	301S11007	挡圈螺钉	Screw, SM3. 57	2
42	140613003	打线凸轮	Lower thread take-up W/S, M	1
43	409S14002	内六角平端紧定螺钉	Set Screw Socket (FT) M6×8	2

M2. 下线过线部件 (9280D) / Lower threading mechanism (9280D)

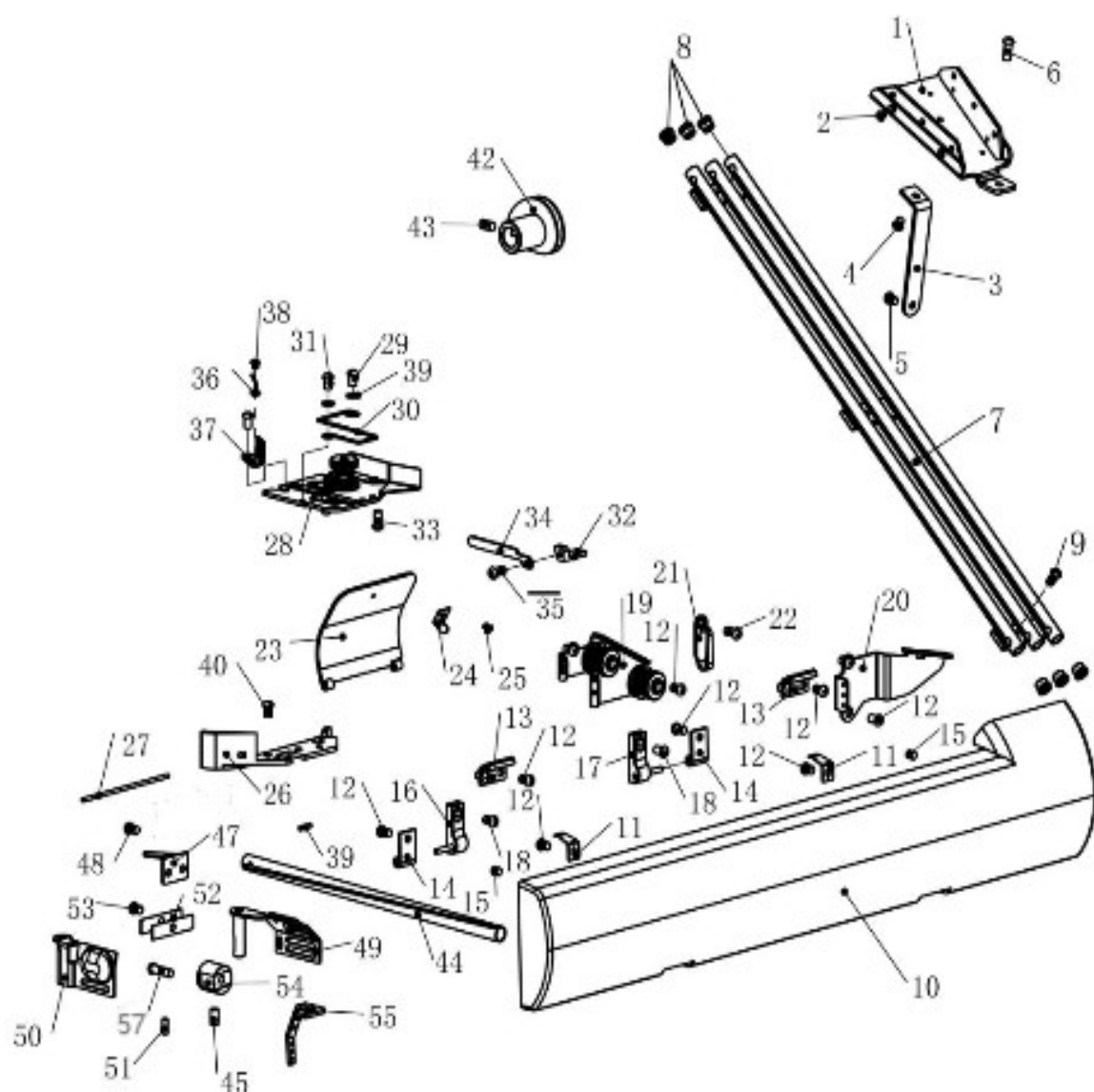

9280-2PL用
9280-2PL series



44	40613020	底线过线管	Lower thread feed bar guide	1
45	409S15004	螺钉	Set screw, SM5. 95	1
47	40619005	剪线刀	Thread trimmer guide plate	1
48	403S11017	复合槽圆柱头螺钉	Screw , pan SM3. 57	1
49	40612031	右弯针盖	Looper cover, RA	1
50	40612032	左弯针盖	Looper cover, LA	1
51	P03015	销 2×8.5	Pin2×8.5	1
52	40612030	弯针盖压板	Spring	2
53	201S11009	螺钉	Screw, pan SM3. 57-40×7	1
54	40601012	护针支架	Looper thread guide bracket	1
55	40613024	导线架	Looper thread guide	1
57	201S11037	螺钉	Screw, pan SM3. 57-40×14	1
58	140619001	剪线刀	Thread trimmer guide plate	1

2PL/PL专用部件/Special components for 2PL/PL

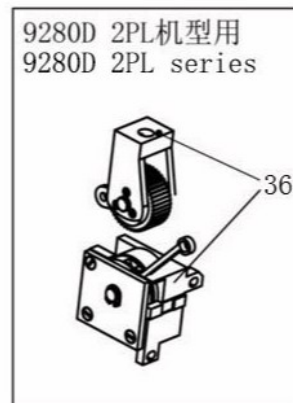
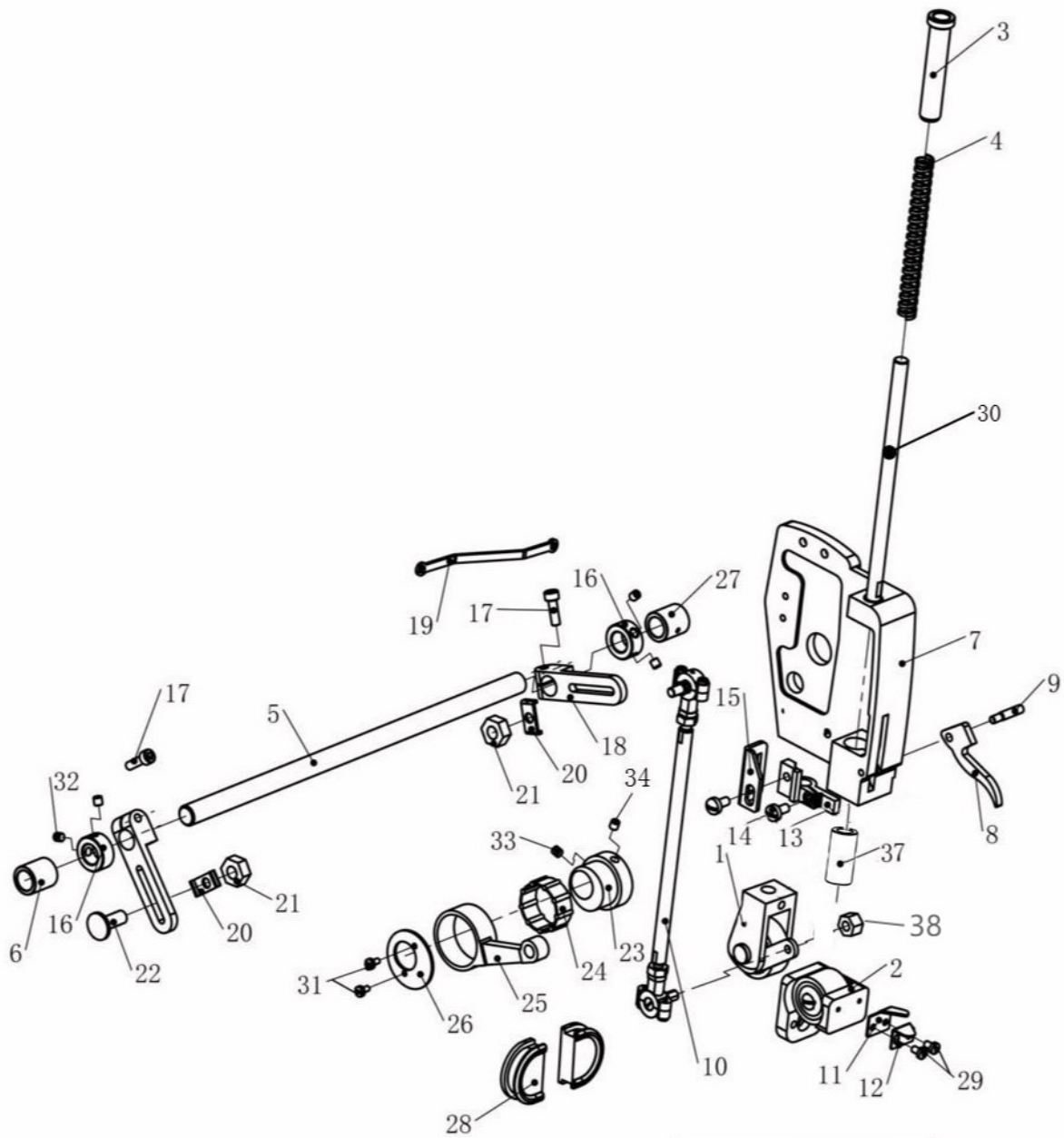

2PL/PL专用部件/Special components for 2PL/PL

序号 REF. NO.	件号 Part NO.	名称	Description	数量 Qty
1	4061402700	上拖轮组件	Upper plastic wheel ass.	1
2	4061402500	下拖轮组件	Lower plastic wheel ass.	1
3	40603019	调节螺母	Adjusting screw	1
4	40627014	拖轮轴弹簧	Presser spring	1
5	40602017	长轴	Long shaft	1
6	40603016	铜套(后)	Long shaft tube (back)	1
7	301151	边盖	Top cover	1
8	40601031	抬压扳手	Lift pressure wrench	1
9	40602013	固定销子	Wrench pin	1
10	4060402400	拉杆组件	Joint bearing base	1
11	40619003	上剪线刀	Top cutter	1
12	40619005	下剪线刀	Bottom cutter	1
13	40609009	压脚轴连接块	Presser bar connecting block	1
14	413S13019	螺钉 M5×13	Screw, M5×13	1
15	40612047	连接片	Connecting piece	1
16	40603020	挡圈	Block ring	2
17	S05004	内六角圆柱头螺钉 M5×14	Set Screw Socket, M5×14	2
18	40605010	偏心调节杆	Adjusting rod neiliu	2
19	40612045	连接板	Thread tension connecting rod	1
20	40612048	刻度指示板	Dial indicating piece	2
21	401S16002	螺帽	Screw	2
22	406S20010	偏心调节杆轴位螺钉	Adjusting rod screw	1
23	40610012	主轴偏心轮	Eccentric wheel	1
24	B07036	滚针轴承 K28×33×13	Needle bearing K28×33×13	1
25	40605009	主轴连杆	Connecting rod	1
26	40612050	固定板	Eccentric wheel piece	1
27	40603013	套筒	Long shaft tube	1
28	40622016	橡皮挡板	Rubber plug	2
29	403S11017	复合槽圆柱头螺钉	Blade set screw	2
30	40602016	拖轮轴	Presser foot rod	1
31	101S11006	支针螺钉	Block piece set screw	2
32	403S14004	螺钉	Block ring set screw	4
33	116S14005	螺钉	Screw	1
34	409S14001	螺钉	Screw	1
35	4061400800	拖轮组件	Upper puller assy	1
36	4061401900	拖轮组件	Puller assy	1
37	40603021	拉杆轴下套	Shaft tube	1
38	406S16005	螺母	Nut	1

PS专用件/Special components for PS

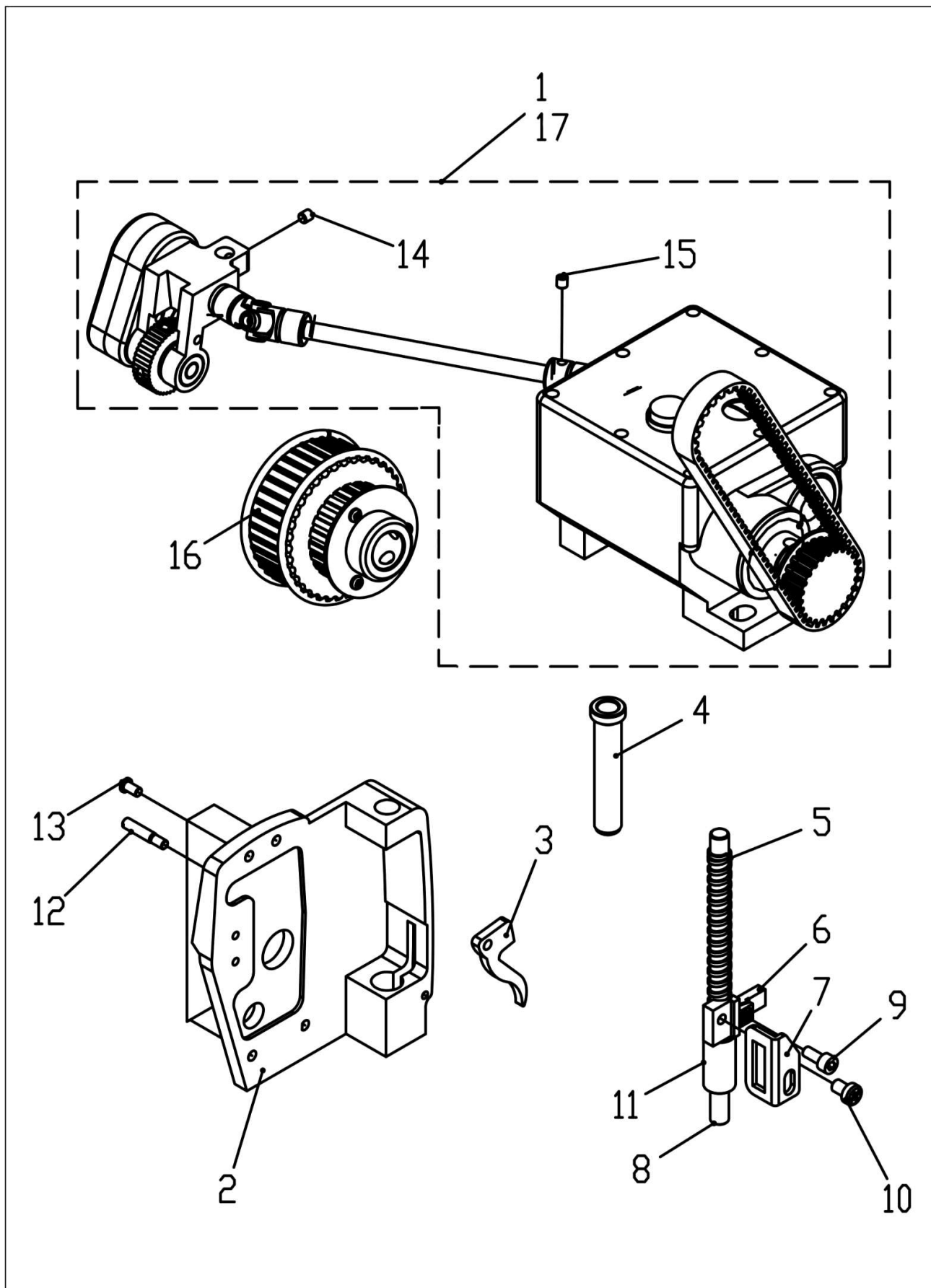

PS专用件/Special components for PS

序号 REF. NO.	件号 Part NO.	名称	Description	数量 Qty
1	4063100400	后拖轮组件 (9280)	Puller wheel asm. (9280)	1
2	301151	边盖	Top cover	1
3	40601031	抬压扳手	Wrench	1
4	40603019	调压螺母	Pressure adjusting screw	1
5	40627014	拖轮轴弹簧	Drag wheel spring	1
6	40609009	压脚轴连接块	Presser bar connecting block	1
7	40612047	连接片	Connecting piece	1
8	40602016	拖轮轴	Presser foot rod	1
9	413S13019	螺钉 M5×12	Screw M5×12	1
10	409S11013	螺钉	Screw	1
11	40603021	拉杆轴下套	Shaft tube	1
12	40602013	固定销子	Wrench pin	1
13	406S11009	螺钉	Top cover set screw	4
14	409S14001	螺钉	Puller bracket screw	1
15	406S12001	螺钉	Screw	8
16	4063502700	上轴步带轮组件	Timing belt wheel assy, upper	1
17	4061402800	后拖轮组件 (9270)	Puller wheel asm. (9270)	1

Z1. 附件/Accessories

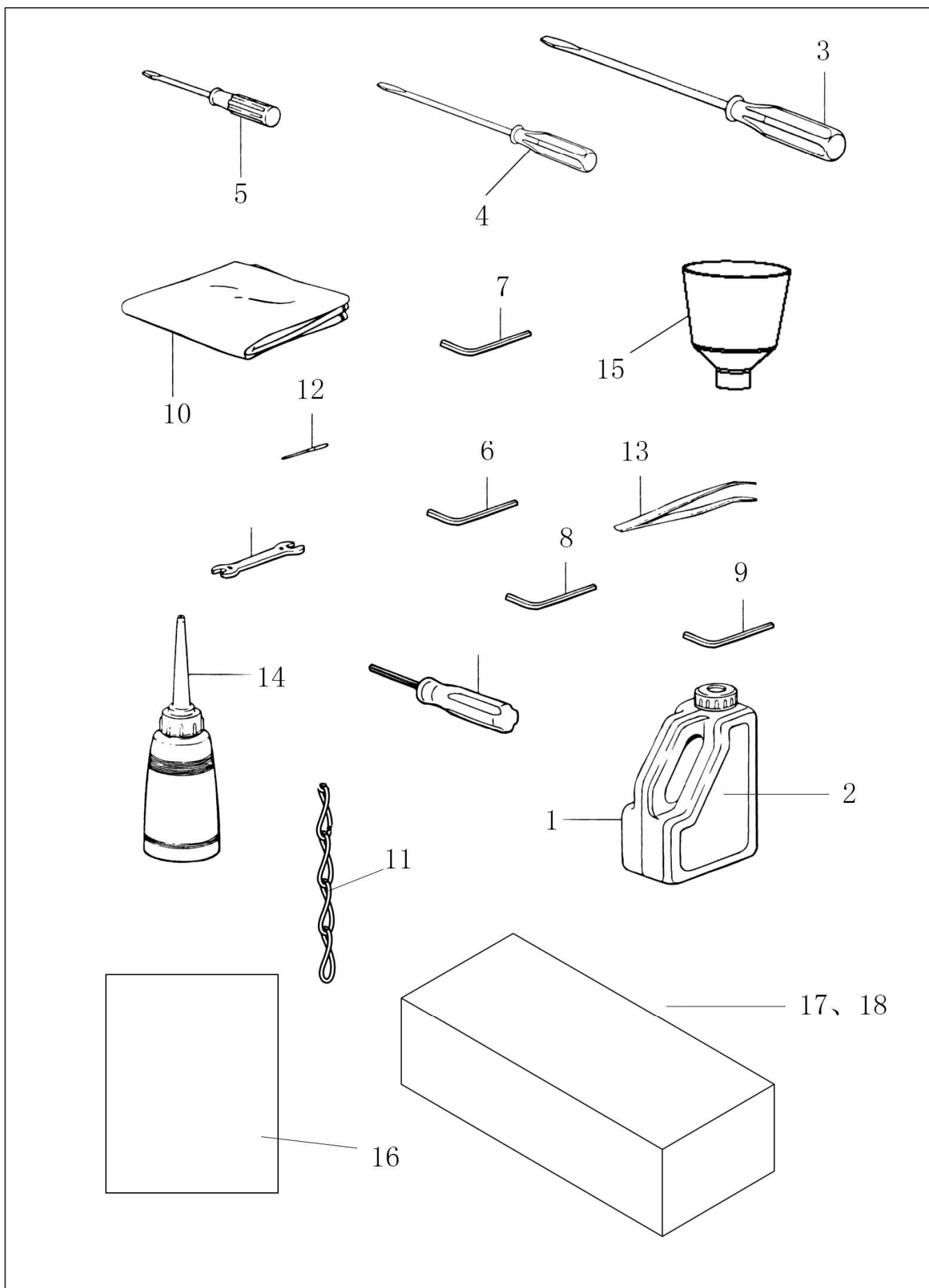

Z1. 附件/Accessories

序号 REF. NO.	件号 Part NO.	名称	Description	数量 Qty
1	915305	工业白油	Industrial white oil	1
2	1011101200	油壶组件	Oiler assy	1
3	10131002	螺丝刀(大)	Screw driver(big)	1
4	10131003	螺丝刀(中)	Screw driver(middle)	1
5	10131004	螺丝刀(小)	Screw driver(small)	1
6	20131047	内六角扳手(4mm)	Hexagonal wrench, 4	1
7	30131005	开口扳手(6mm~7mm)	Open end wrench, 6-7	1
8	30131012	内六角扳手 3mm	Hexagonal wrench, 3	1
9	140631001	内六角扳手 2mm	Hexagonal wrench, 2	1
10	40631003	机头包装袋	Head cover	1
11	40631013	曲腕机链条	Chain	1
12	40617001	机针	Needle	1
13	20131051	镊子	Pincette	1
14	20131038	小油壶(尖嘴)	Oiler assy (small)	1
15	20131039	漏斗	Funnel	1
16	40631021	说明书	Instruction book	1
17	2053102900	四线架组件	Cotton stand assy	1
18	2053103100	六线架组件	Cotton stand assy	1

不同型号的零件清单/Different parts list

序号 REF. NO.	机型 MODEL	针位组件代码 NEEDLES POSITION CODE	卷边器代码 BEADER CODE
1	9270D-12 (1/4)	4063401400	40615026
2	9270D-12 (3/16)	4063401500	40615022
3	9270D-12 (3/16) (雨衣机)	4063401800	40615022
4	9270D-13 (1/8)	4063402300	40615026
5	9270D-12-2PL (1/4)	4063401400	40615026
6	9270D-12-2PL (3/16)	4063401500	40615022
7	9270D-13-2PL (1/8)	4063402300	40615026
8	9270D-12-2PS (1/4)	4063401400	40615026
9	9270D-12-2PS (3/16)	4063401500	40615022
10	9270D-22 (1/4)	4063402100	40615026
11	9270D-22 (3/16)	4063401300	40615023
12	9280D-53 (1/8)	4063401000	4061502700
13	9280D-73-PL (1/8)	4063401600	4061503100
14	9280D-73-2PL (1/8)	4063402000	4061503100
15	9280D-73-PS (1/8)	4063401600	4061503100