

brother

Home Embroidery Machine

PARTS REFERENCE LIST

MODEL: PRS100
VR

www.SwastikSew.com

CONFIDENTIAL

©2015 Brother Industries, Ltd.
All rights reserved.

Published: Jun.,2015
Revised: Apr.,2016

Country Code & Abbreviation of Country Name

Country Code	Abbr.	Country Name	Country Code	Abbr.	Country Name	Country Code	Abbr.	Country Name
USA/Canada			Europe			Asia/Oceania		
200	USA	America	401	ZAF	South Africa	601	KOR	Korea
251	CAN	Canada	402	EGY	Egypt	603	TWN	Taiwan
			411	MUS	Mauritius	604	HKG	Hong Kong
301	PER	Peru				605	VNM	Vietnam
302	ARG	Argentina	501	IRE	Ireland	606	IDN	Indonesia
303	CHL	Chile	502	DEU	Germany	607	PHL	Philippines
304	PRY	Paraguay	503	BEL	Belgium	608	MYS	Malaysia
305	URY	Uruguay	505	UK	United Kingdom	609	SGP	Singapore
306	BRA	Brazil	506	FRA	France	615	IND	India
307	VEN	Venezuela	507	NOR	Norway	616	THA	Thailand
308	MEX	Mexico	508	NLD	Netherlands	622	CHN	China
309	COL	Colombia	509	AUT	Austria			
310	PAN	Panama	510	GRC	Greece	701	AUS	Australia
318	GTM	Guatemala	511	SWE	Sweden	702	NZL	New Zealand
324	GUF	FR. Guiana	515	ESP	Spain			
330	BRB	Barbados	516	PRT	Portugal	902	ISR	Israel
399	-	Latin America 2&5	517	ITA	Italy	903	SYR	Syria
			519	FIN	Finland	904	TUR	Turkey
			520	CHE	Switzerland	905	JOR	Jordan
			521	DNK	Denmark	906	KWT	Kuwait
			524	MLT	Malta	908	SAU	Saudi Arabia
			550	EEU	East Europe	909	IRQ	Iraq
			556	RUS	Russia	910	IRN	Iran
			599	NEU	North Europe	911	CYP	Cyprus
						915	UAE	United Arab Emirates

Meaning of "R" and "H"

No.	CODE	NAME	R/H	REMARKS
1	XA9644050	T BELT	H	
2	XA8474051	UPSET 4X12 DB		
3	XA9652150	MOTOR FAN		
4	XC5764051	MOTOR HOLDER BASE		
5	X57908052	TAPTITE, BIND S M4X10		
6	XE8185001	MAIN MOTOR ASSY	R/H	
7	XC6481051	MOTOR CAP		
8	XA9649050	FEEDER TUBE 3X		
9	XC0443051	SPACER 4X7		
10	XA9650051	MOTOR SPACER PRESSER		
11	052401605	SCREW, PAN (S/P WASHER) M4X16		
12	XC5762051	MOTOR HOLDER		
13	XC5763051	MOTOR HOLDER SPACER		
14	XE1142001	NEEDLE PLATE	R	
15	XC6404051	SCREW, FLAT M4		

High mortality parts

Recommend spare parts & High mortality parts

Recommend spare parts

CONTENTS

(1) MAIN FRAME / COVER	2
(2) UPPER SHAFT MECHANISM.....	6
(3) NEEDLE BAR MECHANISM.....	8
(4) NEEDLE THREADING MECHANISM	12
(5) ELECTRIC PARTS	14
(6) MAIN MOTOR UNIT	18
(7) XYCARRIAGE MECHANISM	20
(8) LOWER SHAFT MECHANISM.....	26
(9) THREAD CUTTING MECHANISM	28
(10) UPPER THREADING MECHANISM	30
(11) ACCESSORY PARTS	32
(12) PACKAGE / USER MANUAL.....	34
SPARE PARTS.....	36

Note on parts:

We keep performance parts for this sewing machine for at least 8 years after this model is discontinued. Performance parts are the necessary parts to maintain the function of the sewing machine.

(1) MAIN FRAME / COVER

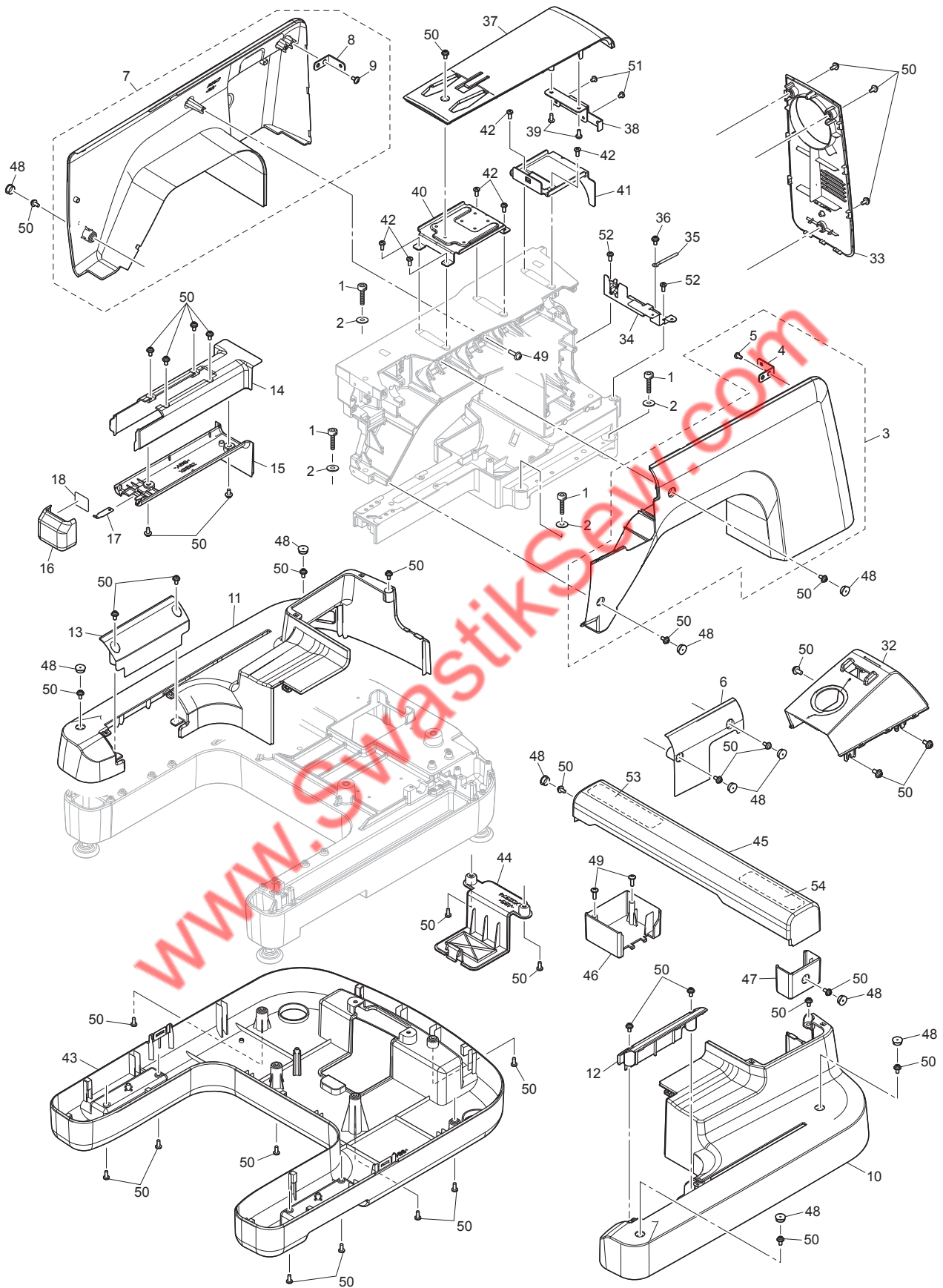

(1) MAIN FRAME / COVER

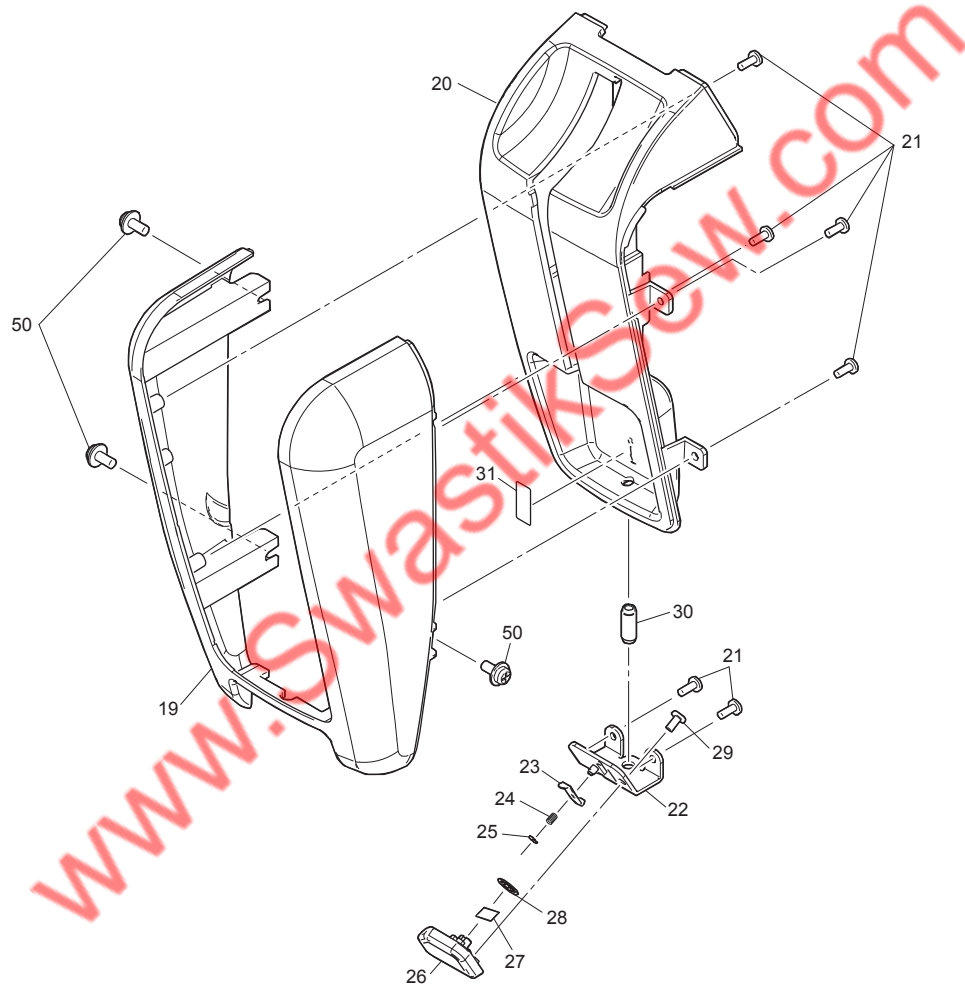

(1) MAIN FRAME / COVER

No.	CODE	NAME	R/H	REMARKS	No.	CODE	NAME	R/H	REMARKS
1	018083536	BOLT SOCKET M8X35			40	XG2461001	ANTENNA BASE PLATE		
2	025080236	WASHER PLAIN M 8			41	XG1783001	BELT SUPPORT		
3	XG2393001	ARM COVER R ASSY (PRS100)	R		42	060401016	SCREW BIND M4X10		
	XG3406001	ARM COVER R ASSY (VR)	R		43	XG2372001	BOTTOM COVER ASSY	R	
4	XG2395001	ARM COVER PLATE			44	XG2374001	BOTTOM COVER LID	R	
5	087410816	TAPTITE CUP B M4X8			45	XG2375001	CARRIAGE COVER	R	
6	XG2350001	ARM COVER R LID	R		46	XG2376001	MOTOR COVER	R	
7	XG2394001	ARM COVER L ASSY (PRS100)	R		47	XG2377001	CARRIAGE COVER UNDER	R	
	XG3247001	ARM COVER L ASSY (VR)	R		48	XC5594052	SCREW COVER		
8	XG2395001	ARM COVER PLATE			49	087411416	TAPTITE CUP B M4X14		
9	087410816	TAPTITE CUP B M4X8			50	0A5401006	SCREW PAN (S/P WASHER) M4X10		
10	XG2353001	BASE COVER R ASSY	R		51	060400516	SCREW BIND M4X5		
11	XG2355001	BASE COVER L ASSY	R		52	X57908052	TAPTITE,BIND S M4X10		
12	XG2357001	BASE COVER R LID ASSY	R		53	XE8643101	LABEL INJURY 32X161		
13	XG2359001	BASE COVER L LID ASSY	R		54	XE8328101	LABEL INJURY 32X161		
14	XG1775001	BED COVER TOP	R						
15	XG1562001	BED COVER BOTTOM	R						
16	XG2538001	HOOK COVER ASSY (USA, CAN)	R						
	XG1561001	ROTARY HOOK COVER (OTHER)	R						
17	X53638151	SPRING							
18	XC6552051	OILING CAUTION LABEL							
19	XG3403001	TAKE UP LEVER COVER (PRS100)	R						
	XG3267001	TAKE UP LEVER COVER (VR)	R						
20	XG2366001	ARM COVER FRONT	R						
21	085310816	TAPTITE BIND B M3X8							
22	XG2380001	THRED HOLDER BASE ASSY							
23	XG1621001	NEEDLE THREAD PRESSER PLATE							
24	XC5962051	SPRING							
25	048015343	RETAINING RING E1.5							
26	XG1622001	CUTTER COVER							
27	X80321001	NT LOWER THREAD CUTTER							
28	138384051	RETAINING RING,CS5							
29	085310616	TAPTITE BIND B M3X6							
30	XG1759001	THREAD GUIDE SHAFT							
31	XG3901001	NEEDLE THREADER LABEL TAC							
32	XG1758001	THREAD TENSION COVER PRINT	R						
33	XG3404001	PULLEY COVER PRINT (PRS100)	R						
	XG2368001	PULLEY COVER (VR)	R						
34	XG2369001	PULLEY COVER PLATE							
35	137947001	CLIP							
36	060300516	SCREW BIND M3X5							
37	XG2371001	ARM COVER UPPER	R						
38	XG1777001	ARM COVER UPPER PLATE							
39	085411015	TAPTITE BIND B M4X10							

(1) MAIN FRAME / COVER

Blank page

www.SwasikSew.com

(2) UPPER SHAFT MECHANISM

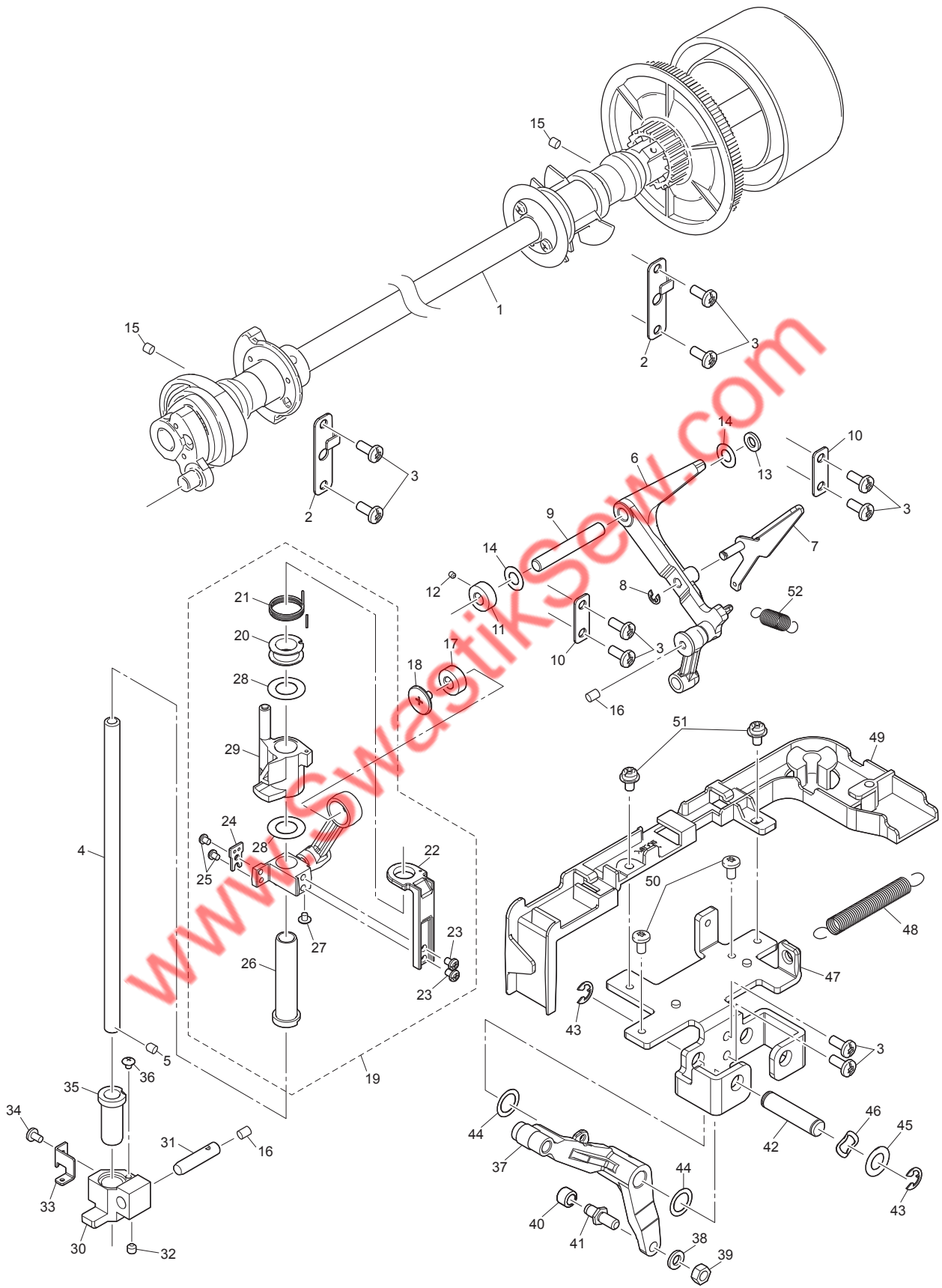

(2) UPPER SHAFT MECHANISM

No.	CODE	NAME	R/H	REMARKS	No.	CODE	NAME	R/H	REMARKS
1	XG2535001	UPPER SHAFT SUPPLY ASSY B			45	XG1662001	WASHER 8		
2	XC6362051	METAL PRESSER			46	XG1663001	WASHER SPRING		
3	X57908052	TAPTITE,BIND S M4X10			47	XG1664001	TAKE-UP LINK HOLDER		
4	XC5623051	BASE NEEDLE BAR			48	XG1779001	TAKE-UP LINK SPRING		
5	014500632	SET SCREW SOCKET (CP) M5X6			49	XG1665001	LEFT LEAD WIRE HOLDER		
6	XG1582001	DRIVING LEVER A ASSY			50	060400616	SCREW BIND M4X6		
7	XG1650001	DRIVING LEVER B P-FOOT ASSY			51	XC7566051	SCREW, PAN(S/P WASHER)M4X8		
8	048030343	RETAINING RING E3			52	XG2539001	PRESSER CAM SPRING		
9	XG1653001	DRIVING SHAFT P-FOOT							
10	XC2297051	PRESSER PLATE A							
11	130676151	SET SCREW COLLAR							
12	014400632	SET SCREW SOCKET (CP) M4X6							
13	137976051	WASHER 6							
14	X50546050	WASHER,THRUST							
15	XC3183051	FELT							
16	XZ0207051	LINK FELT,3.3M							
17	147777000	NEEDLE BEARING							
18	145465001	SCREW, SM3.57-40X6 L							
19	XG3831001	JUMP BRACKET ASSY	H						
20	XC5616051	J SPRING COLLAR							
21	XC5617051	J SPRING							
22	XC5614051	J BRACKET							
23	062300416	SCREW PAN M3X4							
24	XC5622051	J CUSHION BASE							
25	062260316	SCREW PAN M2.6X3							
26	XC5621051	J VERTICAL BUSH							
27	008260304	SCREW TRUSS M2.6X3							
28	131976050	WASHER,THRUST							
29	XE7550001	JUMP BRACKET							
30	XC5635151	P-FOOT VERTICAL BASE							
31	XC5636151	P-FOOT VERTICAL PIN							
32	014400432	SET SCREW SOCKET (CP) M4X4							
33	XC5638251	PRESSER FOOT CUSHION BASE	H						
34	060300516	SCREW BIND M3X5							
35	XC5637051	P-FOOT VERTICAL BUSH							
36	008260304	SCREW TRUSS M2.6X3							
37	XG1655001	TAKE-UP LINK A ASSY							
38	028050246	WASHER SPRING 2-5							
39	021500103	NUT, 1 M5							
40	XC5628051	ROLLER							
41	XC5629051	ROLLER SHAFT							
42	XG1657001	TAKE-UP LINK SHAFT							
43	048050343	RETAINING RING E5							
44	XF3183001	WASHER THRUST 8.6							

(3) NEEDLE BAR MECHANISM

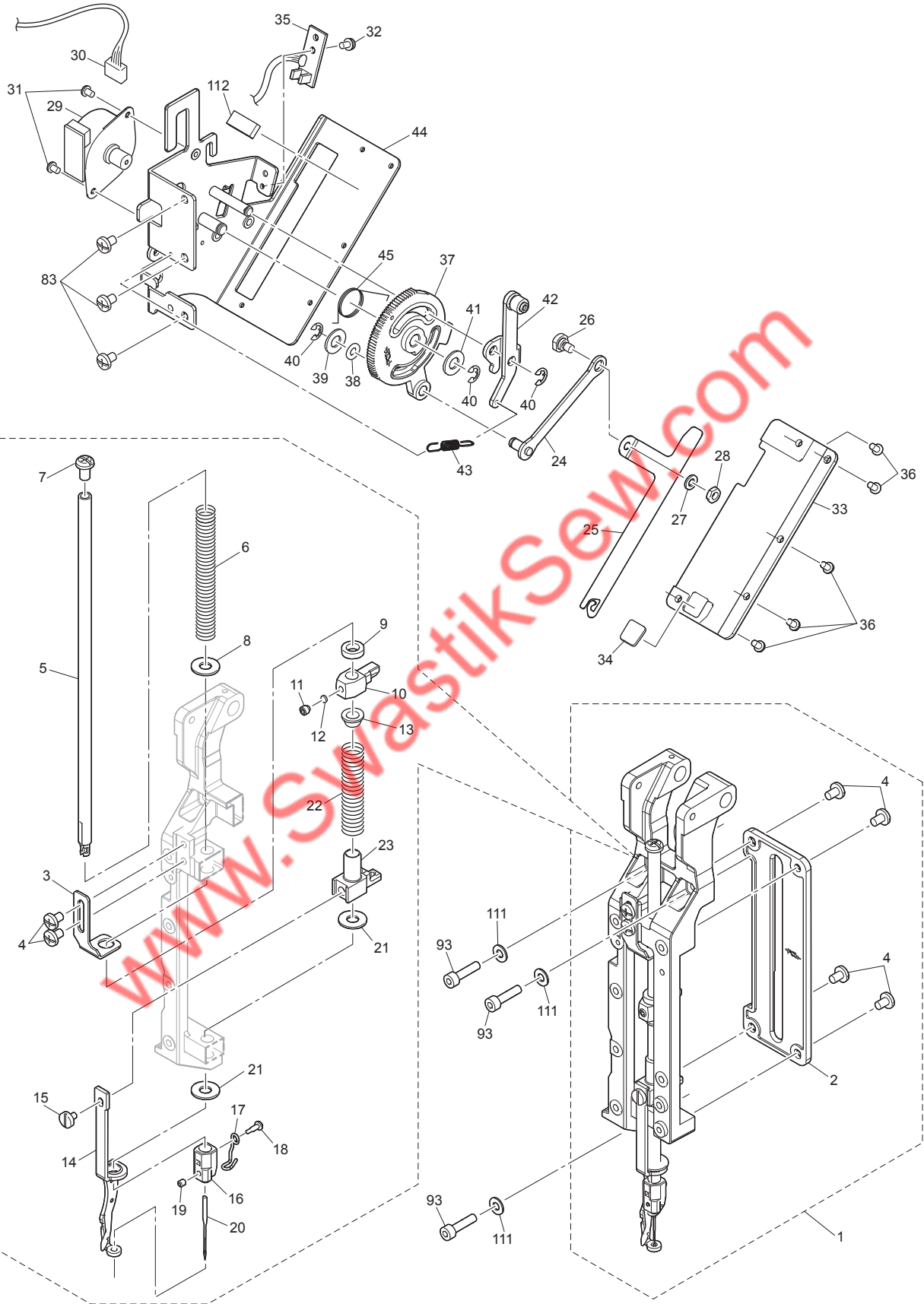

(3) NEEDLE BAR MECHANISM

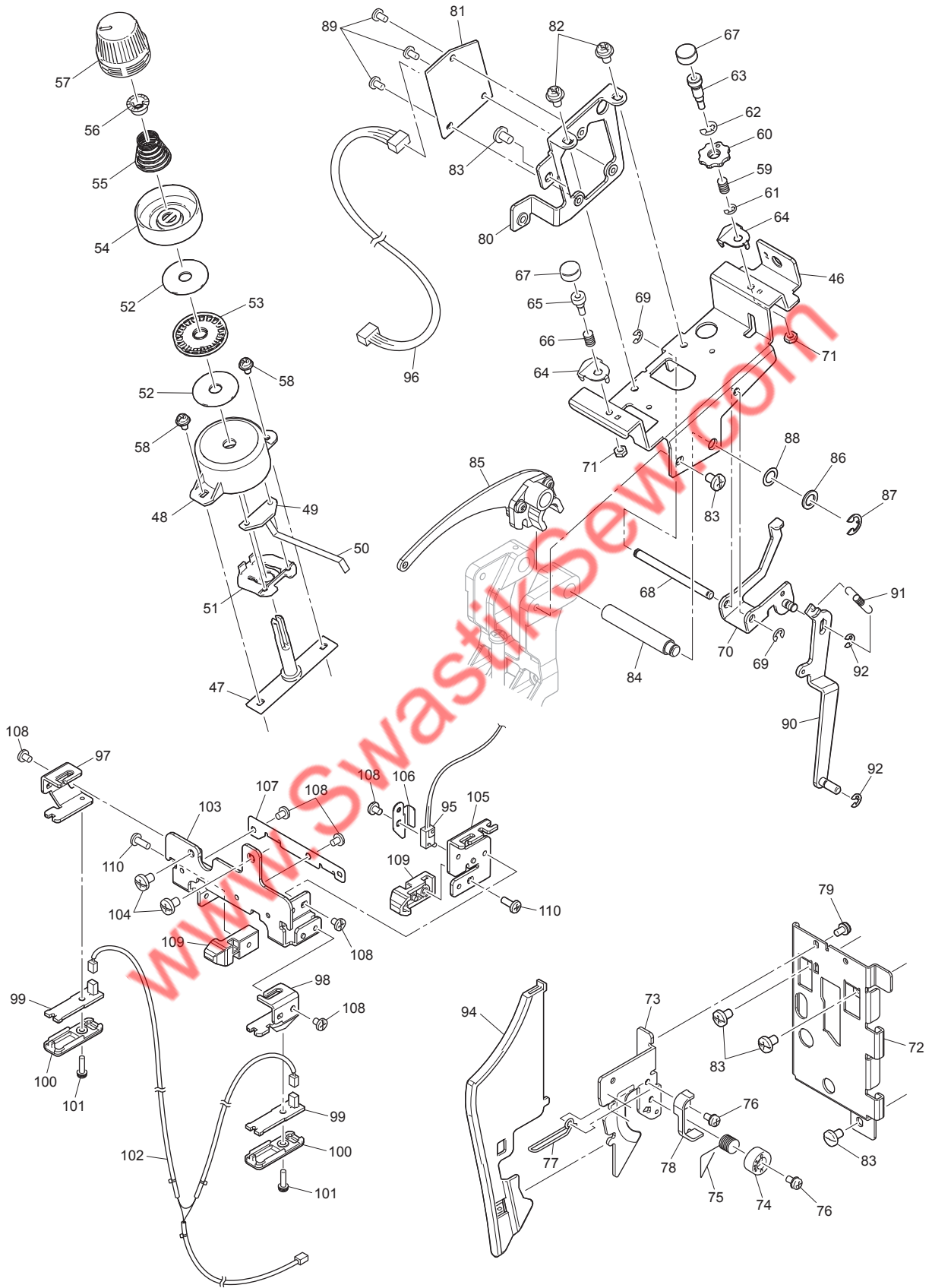

(3) NEEDLE BAR MECHANISM

No.	CODE	NAME	R/H	REMARKS	No.	CODE	NAME	R/H	REMARKS
1	XG1667001	NEEDLE-PRESSER ASSY			45	XG2528001	WIPER TORSION SPRING		
2	XG1669001	GUIDE RAIL NEEDLE BAR			46	XG1685001	INNER THREAD EYELET BASE		
3	XC5678151	TOP DEAD CENTER PLATE			47	XC5911151	THREAD TENSION BRACKET		
4	060400616	SCREW BIND M4X6			48	XC5914156	THREAD QUANTITY SENSOR COVER		
5	XC5679051	NEEDLE BAR			49	XC6167051	ASSY: TH SENSOR		
6	XC5680051	SPRING, NEEDLE BAR			50	XC6192051	FFC:SML2CD-H		
7	062500816	SCREW PAN M5X8			51	XE8022001	THREAD QUANTITY SENSOR PRESSER		
8	118735002	WASHER			52	S36299001	TENSION DISC FELT	H	
9	S36153100	RUBBER, CUSHION	H		53	XC7602000	ROTARY DISC ASSY B		
10	XE1172001	NEEDLE BAR CRAMP			54	XC5915052	TENSION DISC PRESSER		
11	014680432	SET SCREW SOCKET SM4.37-40X4			55	XC6232051	TENSION SPRING	H	
12	100507050	WASHER			56	S30564000	WASHER		
13	XC5682051	PRESSER FOOT SPRING COLLAR			57	XE8114003	TENSION NUT		
14	XC5685151	PRESSER FOOT ASSY			58	XC7564051	SCREW PAN(S/P WASHER)M3X6		
15	XC5688051	SCREW, P/F			59	XG1127001	THREAD GUIDE COMPRESSION		
16	XC5690051	THREAD GUIDE, NEEDLE BAR			60	XG1130001	NUT		
17	XC7020051	THREAD GUIDE			61	048025343	RETAINING RING E2.5		
18	XC7021052	SCREW SM 2.38			62	048040343	RETAINING RING E4		
19	016300436	SET SCREW SOCKET (CN) M3X4			63	XG1128001	THREAD GUIDE TENSION SCREW		
20	XC5691011	NEEDLE HAX130 EBBR			64	XC5907051	THREAD GUIDE TENSION PLATE		
21	XC7249052	NEEDLE BAR FELT S	H		65	XC5906051	THREAD GUIDE TENSION AXIS		
22	XC5683051	PRESSER FOOT SPRING			66	XZ0198051	BOBBIN WINDER COMPRESSION		
23	XC5684051	PRESSER FOOT CLAMP			67	XC5919053	TENSION AXIS CAP		
24	XG1671001	WIPER LINK ASSY			68	XG1687001	THREAD TENSION R SHAFT		
25	XG1673001	WIPER HOOK	H		69	048030343	RETAINING RING E3		
26	XC5892051	WIPER SHOULDER SCREW			70	XG2472001	THREAD TENSION R LINK A ASSY		
27	028040246	WASHER SPRING 2-4			71	021300205	NUT 2 M3		
28	021400305	NUT 3 M4			72	XG1711001	THREAD TENSION BRACKET BASE		
29	XG2547001	PULSE MOTOR:W M35SP-9NK			73	XC5921151	THREAD TAKE-UP BRACKET ASSY		
30	XG2562001	LEAD WIRE ASSY WPM			74	XC6463051	THREAD CATCHING SPRING CASE		
31	062300416	SCREW PAN M3X4			75	XC5926051	THREAD TAKE-UP SPRING	R/H	
32	XC7564051	SCREW PAN(S/P WASHER)M3X6			76	0A4300606	SCREW PAN (S/P WASHER) M3X6		
33	XG1674001	WIPER GUIDE			77	XC5929051	THREAD GUIDE WIRE	H	
34	XG1675001	WIPER CUSHION			78	XC6234051	THREAD GUARD		
35	XG3108001	WIPER SENSOR PCB ASSY			79	060300416	SCREW BIND M3X4		
36	062300616	SCREW PAN M3X6			80	XG1689001	HEAD PCB HOLDER		
37	XG1676001	WIPER LEVER			81	XG2211001	HEAD PCB ASSY		
38	X53838051	WASHER			82	XC7566051	SCREW, PAN(S/P WASHER)M4X8		
39	025050236	WASHER PLAIN M 5			83	060400616	SCREW BIND M4X6		
40	048040343	RETAINING RING E4			84	XG1690001	THREAD TAKE-UP SHAFT		
41	025060235	WASHER PLAIN M 6			85	XC5673051	THREAD TAKE-UP LEVER ASSY		
42	XG1677001	JAMP DRIVING LEVER ASSY			86	137976051	WASHER 6		
43	XG1679001	JAMP DRIVING LEVER SPRING1			87	048050343	RETAINING RING E5		
44	XG1680001	WIPER BASE ASSY			88	X53838051	WASHER		

(4) NEEDLE THREADING MECHANISM

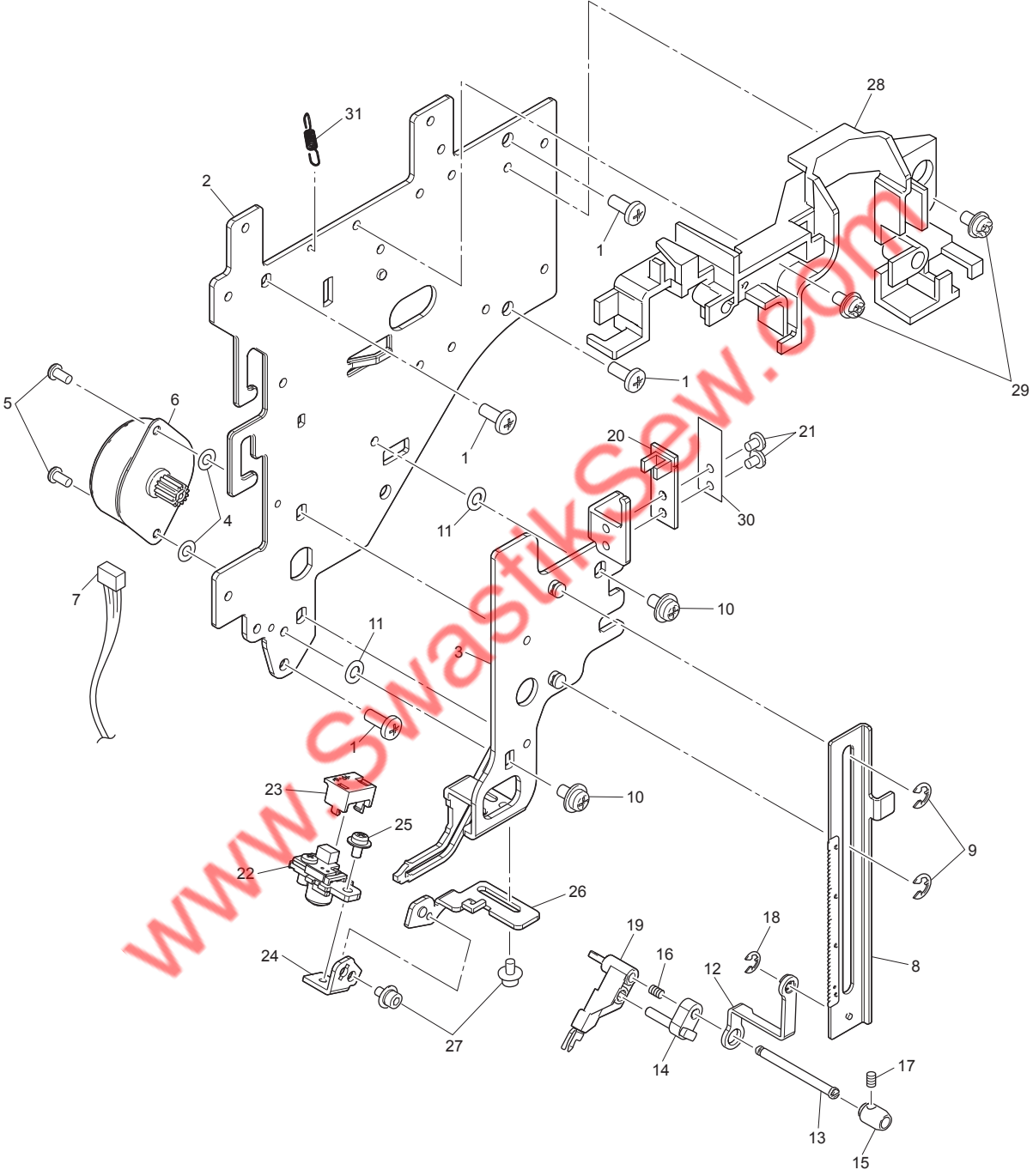

(5) ELECTRIC PARTS

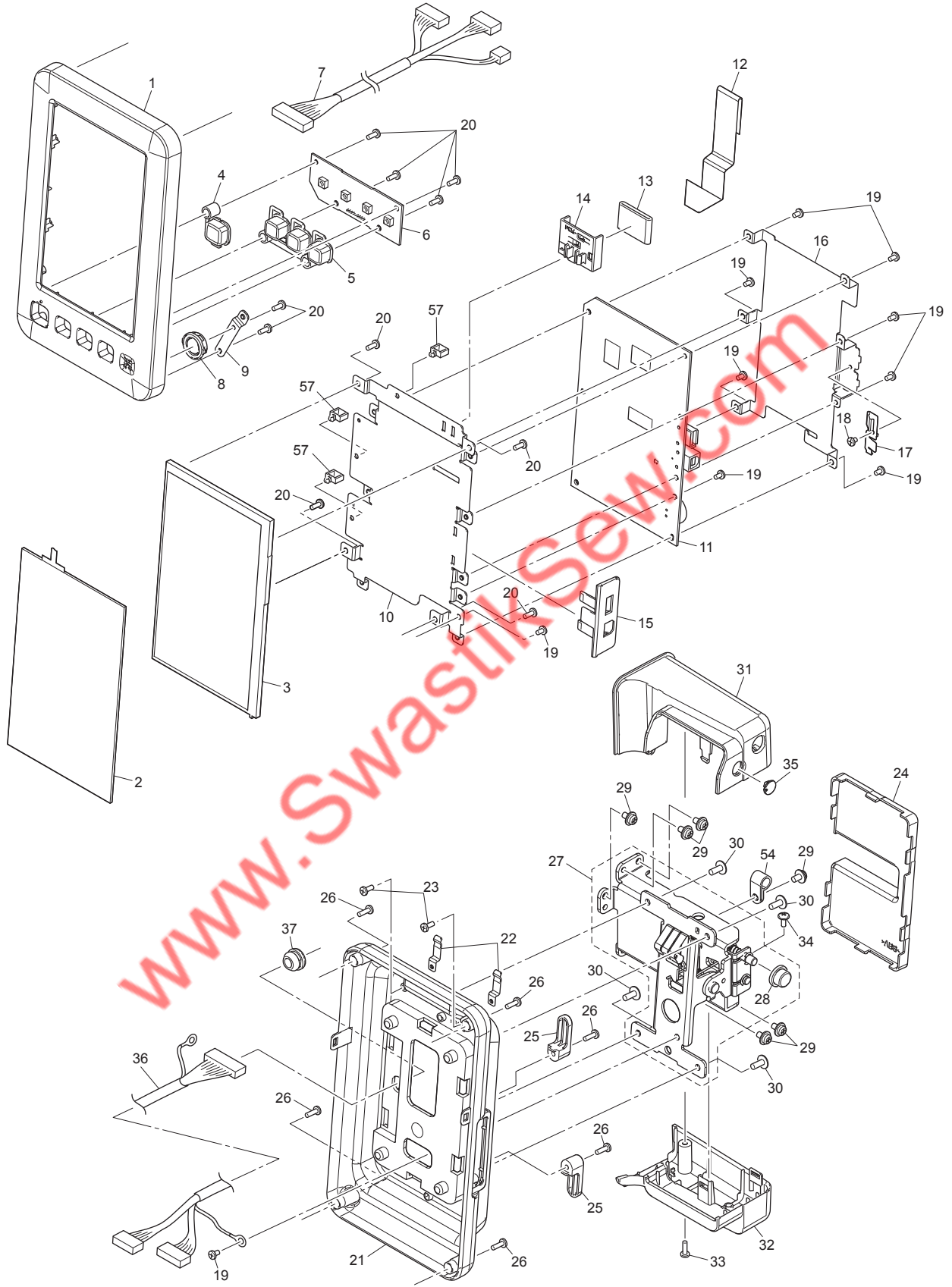

(5) ELECTRIC PARTS

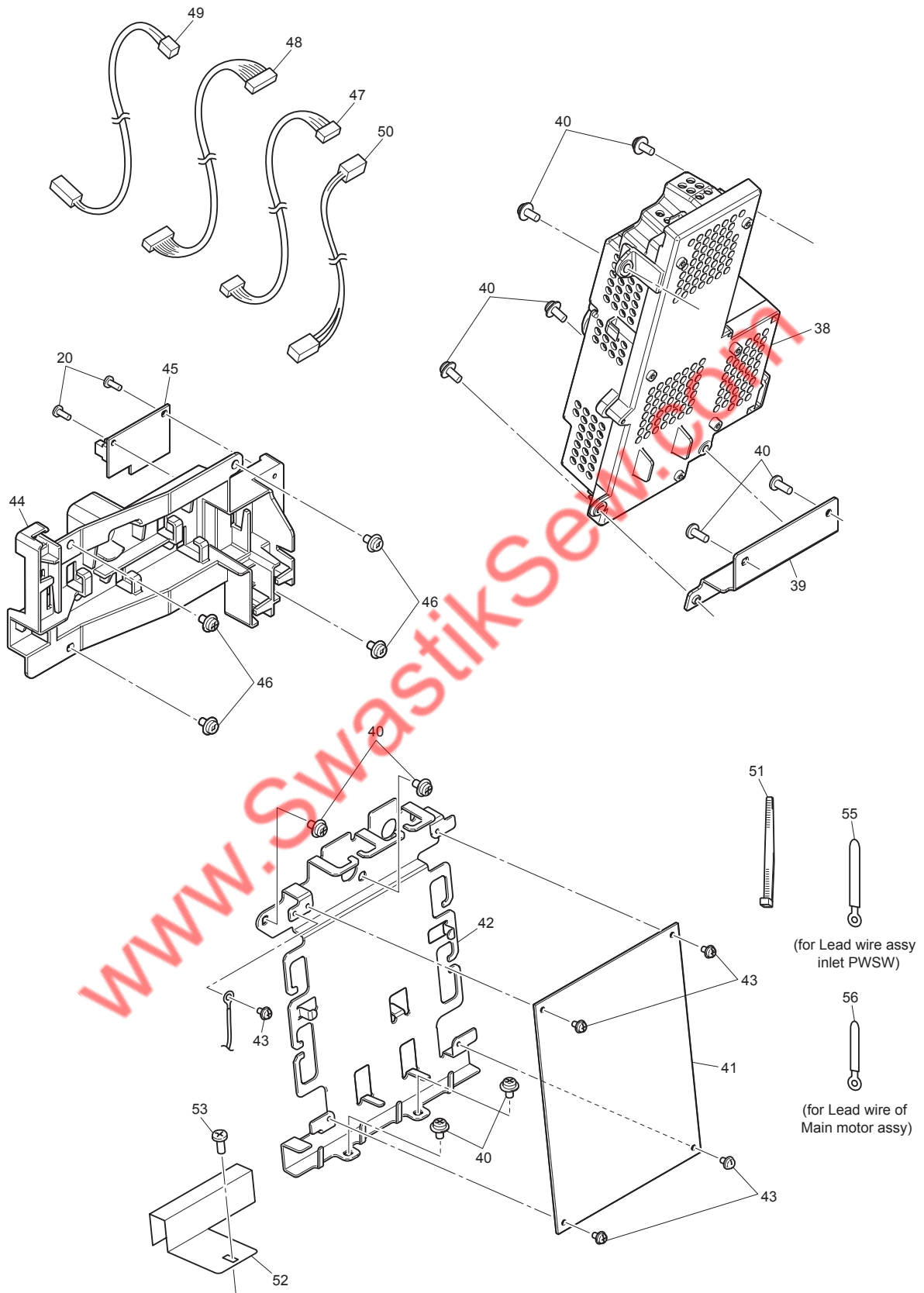

(5) ELECTRIC PARTS

No.	CODE	NAME	R/H	REMARKS	No.	CODE	NAME	R/H	REMARKS
1	XG1719001	PANEL FRONT COVER PRINTED (PRS100)	R		44	XG1573001	NP PCB HOLDER		
	XG3251001	PANEL FRONT COVER PRINTED (VR)	R		45	XG2242001	NP PCB ASSY		
2	XG2559001	TOUCH PANEL:T010-1303-T360	R		46	0A5400806	SCREW PAN (S/P WASHER) M4X8		
3	XG3916001	LCD SUPPLY ASSY	R		47	XG2555001	LEAD WIRE ASSY POWER-MAIN E1		
4	XG1724001	SS BUTTON			48	XG2805001	LEAD WIRE ASSY MOTOR DRIVE		
5	XG1727001	OPERATION BUTTON			49	XG2556001	LEAD WIRE ASSY MOTOR-MD E1		
6	XG2192001	SS PCB ASSY			50	XG2557001	LEAD WIRE ASSY POWER-MD E1		
7	XG2199001	LEAD WIRE ASSY SS			51	X53169050	BAND		
8	XG3933001	SPEAKER ASSY			52	XC5157051	PROTECT SHEET		
9	XG3311001	SPEAKER HOLDER			53	060400516	SCREW BIND M4X5		
10	XG3683001	PCB BASE PLATE ASSY			54	XG3713001	CORD CLAMP:WL-1/4S		
11	XG3759001	PANEL PCB SUPPLY ASSY	R/H		55	XG0870001	COATING CLIP		
12	XF4441001	FLEXIBLE FLAT CABLE:SML2SC-40			56	137947001	CLIP		
13	XE9920001	FERRITE CORE:FSRC310200RN000T			57	XE8225001	CORD CLAMP:LWSM-0605		
14	XE9963001	FERRITE HOLDER WIDE							
15	XG1731001	USB COVER							
16	XG1733001	PANEL PCB CASE							
17	XF2979001	GROUND PLATE USB							
18	060300416	SCREW BIND M3X4							
19	060300516	SCREW BIND M3X5							
20	136681051	TAPTITE, BIND B M3X8							
21	XG1735001	PANEL REAR COVER	R						
22	XE6246003	PEN HOLDER							
23	136681051	TAPTITE, BIND B M3X8							
24	XG1736001	PANEL REAR COVER R	R						
25	XD0761053	USB CORD HOLDER							
26	X59629051	TAPTITE BIND B M3X10							
27	XG1737001	PANEL HOLDER ASSY							
28	XG1754001	PANEL STOPPER BUTTON							
29	0A5400806	SCREW PAN (S/P WASHER) M4X8							
30	087411016	TAPTITE CUP B M4X10							
31	XG1755001	PANEL ARM COVER A	R						
32	XG1756001	PANEL ARM COVER B	R						
33	X59629051	TAPTITE BIND B M3X10							
34	087310816	TAPTITE CUP B M3X8							
35	XE4277001	SCREW CAP							
36	XG2679001	LEAD WIRE ASSY PANEL-MAIN							
37	XC7233051	CORD BUSHING 5P-4							
38	XG2574001	POWER SUPPLY UNIT E1	R/H						
39	XG1576001	POWER UNIT COVER HOLDER							
40	0A5401006	SCREW PAN (S/P WASHER) M4X10							
41	XG3760001	MAIN PCB SUPPLY ASSY	R/H						
42	XG1572001	MAIN PCB HOLDER							
43	XC7564051	SCREW PAN(S/P WASHER)M3X6							

(5) ELECTRIC PARTS

Blank page

www.SwasikSew.com

(6) MAIN MOTOR UNIT

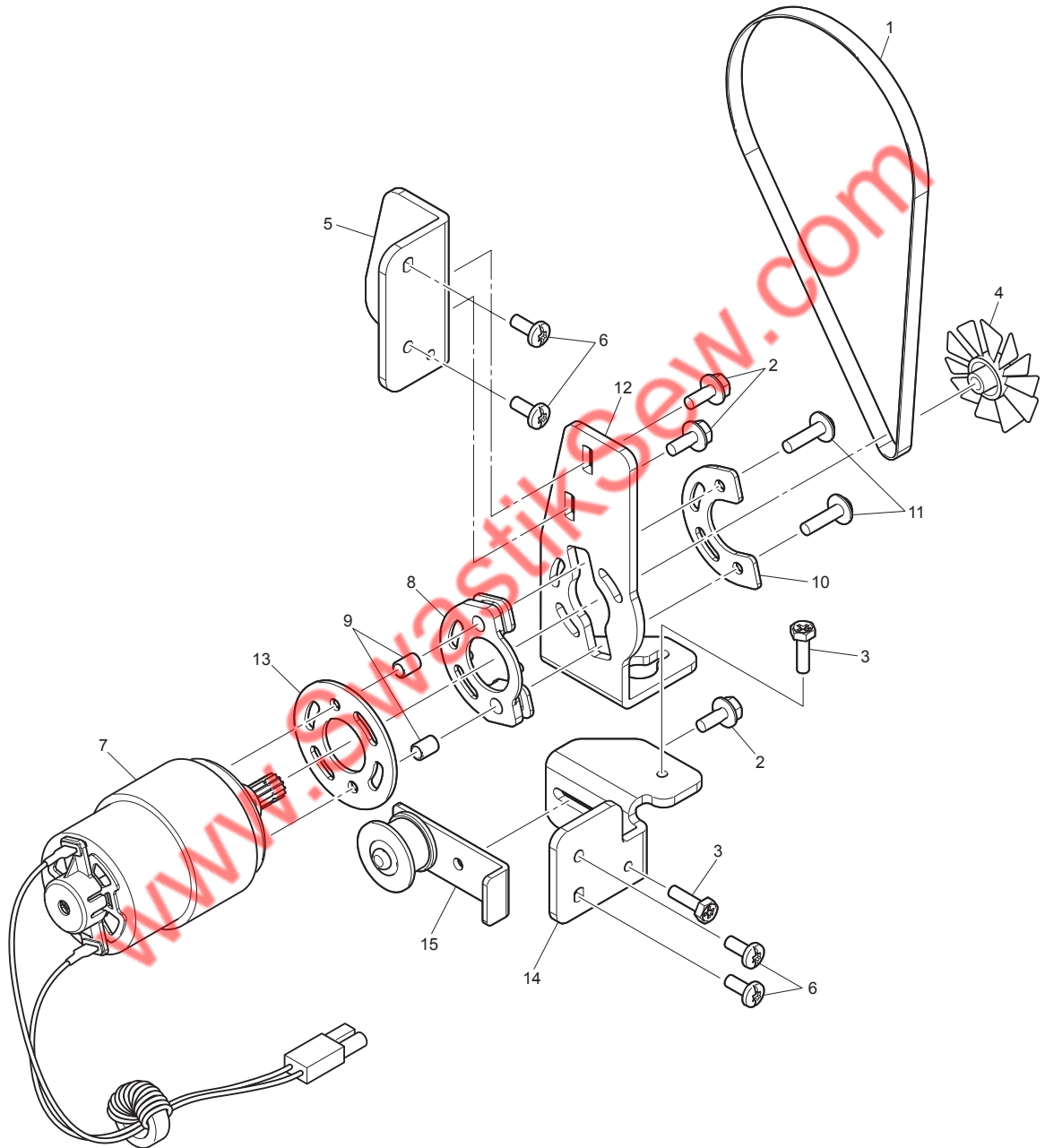

(7) XYCARRIAGE MECHANISM

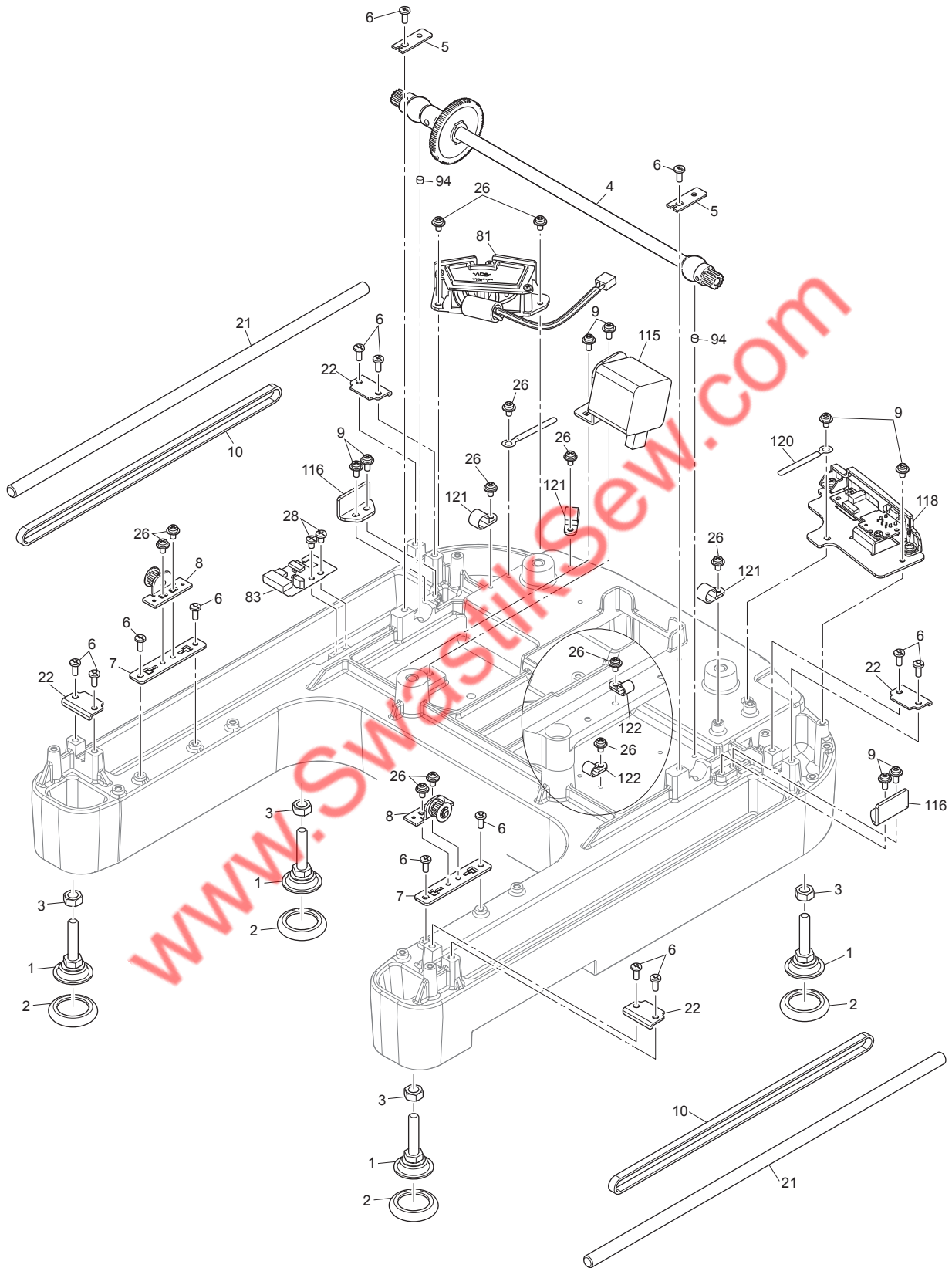

(7) XYCARRIAGE MECHANISM

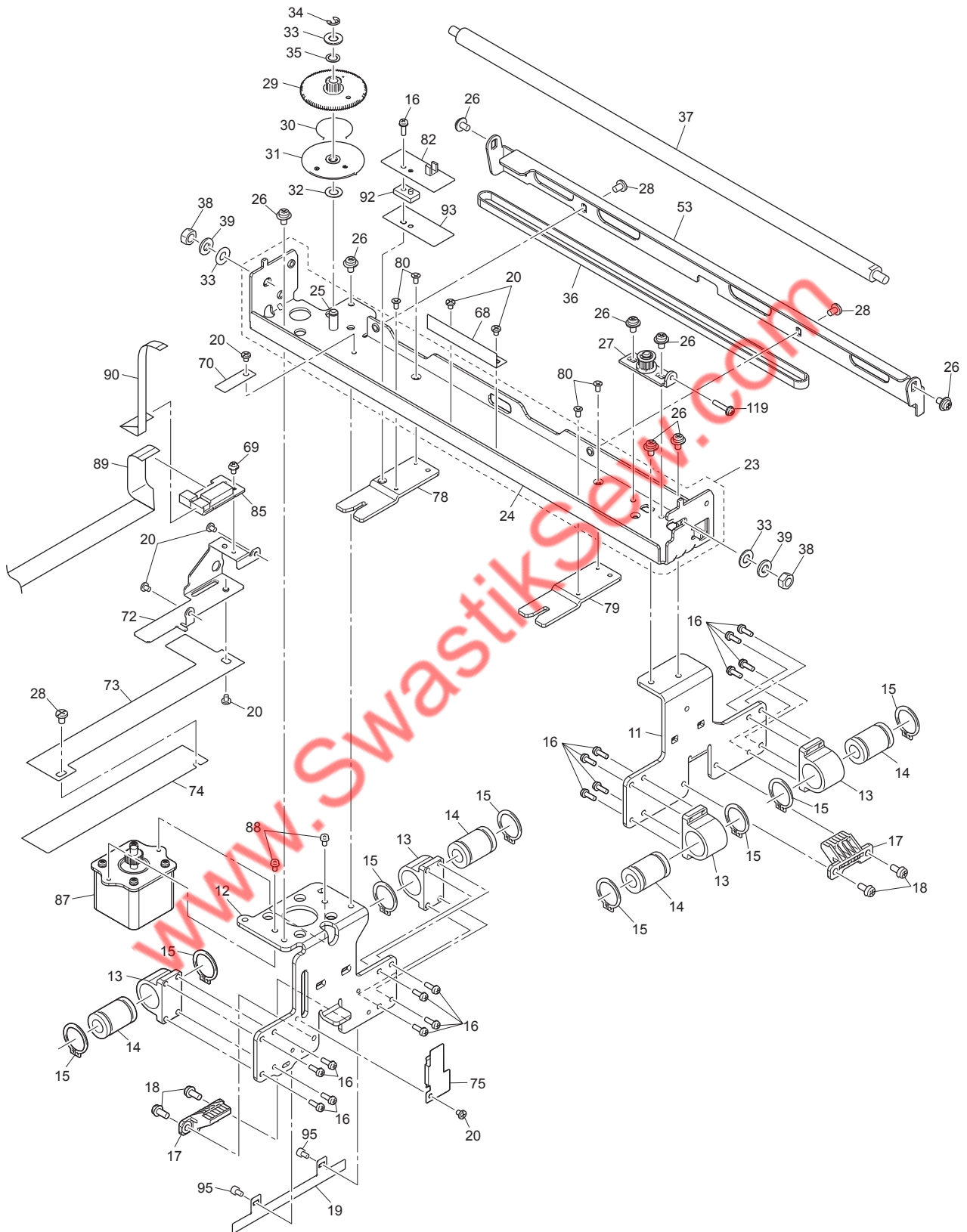

(7) XYCARRIAGE MECHANISM

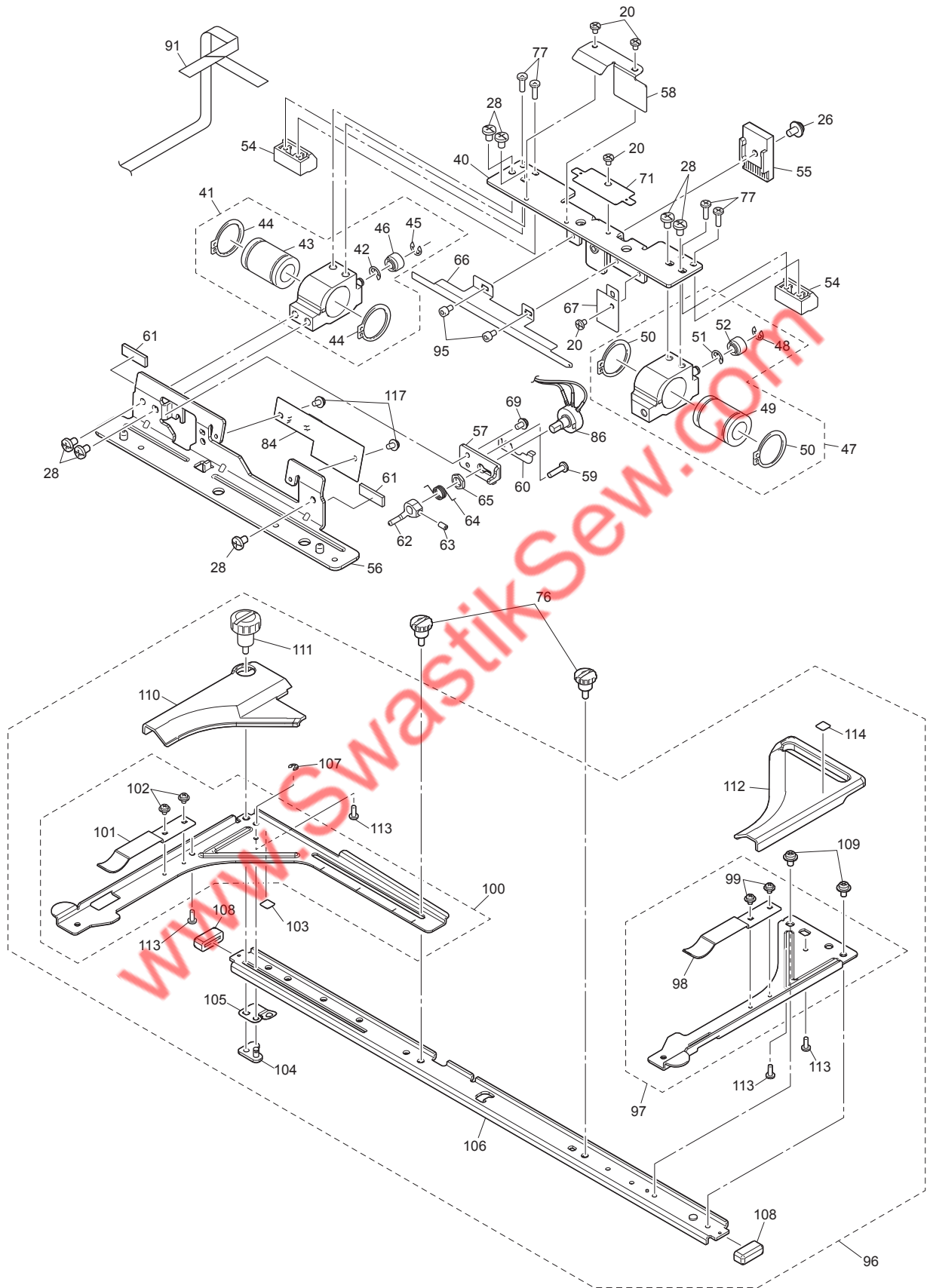

(7) XYCARRIAGE MECHANISM

No.	CODE	NAME	R/H	REMARKS	No.	CODE	NAME	R/H	REMARKS
1	XD0747051	ADJUST BOLT M8			45	048040343	RETAINING RING E4		
2	XD0752051	RUBBER CUSHION	H		46	XC5796051	X ROLLER		
3	021080206	NUT 2 M8			47	XF2061001	BEARING CASE XB ASSY		
4	XG1620001	Y DRIVING SHAFT ASSY			48	048040343	RETAINING RING E4		
5	X52478051	BUSHING PRESSER			49	XC6222001	BEARING 12 LINER		1000052910
6	X57908052	TAPTITE,BIND S M4X10			50	048210142	RETAINING RING, EXTERNAL C21		
7	XG1615001	TENSIONG PULLEY BASE PLATE			51	048040343	RETAINING RING E4		
8	XG1600001	Y TENSION PLATE SET			52	XC5796051	X ROLLER		
9	0A5401006	SCREW PAN (S/P WASHER) M4X10			53	XG1590001	X FEED FRAME B		
10	XC5775051	T BELT B60S3M579			54	XC6218051	Y FRAME SPACER		
11	XG1592001	Y CARRIAGE R			55	XC5798051	X BELT PRESSER		
12	XG1593001	Y CARRIAGE L			56	XG1478001	X CARRIAGE AX SUB ASSY		
13	XC5779051	BEARING CASE Y			57	XF2148001	X CARRIAGE CX		
14	XC5780051	BEARING 10 ,LINER			58	XF2163001	X CARRIAGE DX		
15	048190142	RETAINING RING, EXTERNAL C19			59	060301216	SCREW BIND M3X12		
16	0A4301006	SCREW PAN (S/P WASHER) M3X10			60	XE7362001	PT METER PLATE B		
17	XG1597001	Y BELT PRESSER			61	XE8211001	X CARRIAGE SLIDING SHEET		
18	0A4401006	SCREW PAN (S/P WASHER) M4X10			62	XC5801051	HOOP LEVER		
19	XC5782051	Y SENSOR DOG			63	012300632	SET SCREW SOCKET (FT) M3X6		
20	060300416	SCREW BIND M3X4			64	XC5802051	SPRING		
21	XC5783051	Y GUIDE SHAFT			65	X52569001	NUT		
22	XC5784251	FIXED Y SHAFT PLATE			66	XG1594001	X SENSOR DOG		
23	XG1589001	FEED FRAME ASSY			67	XC5804051	X CABLE FIXING SHEET A		
24	XG1588001	FEED FRAME			68	XG3078001	X CABLE FIXING SHEET B		
25	XC5787051	SHAFT			69	XC7564051	SCREW PAN(S/P WASHER)M3X6		
26	0A5400806	SCREW PAN (S/P WASHER) M4X8			70	XC5806051	X CABLE FIXING SHEET C		
27	XE7129001	TENSION PULLEY ASSY			71	XF2149001	X CABLE FIXING SHEET E		
28	060400616	SCREW BIND M4X6			72	XC5807051	PCB SET PLATE		
29	XC3227001	Y DRIVING GEAR PULLEY A			73	XC5808051	Y CABLE PROTECTION SHEET A		
30	XC3194051	SPRING FOR GEAR			74	XC6121051	Y CABLE PROTECTION SHEET B		
31	XC3192001	Y DRIVING GEAR PULLEY B			75	XC5809151	CODE GRIP		
32	X50546050	WASHER,THRUST			76	XC5817051	SCREW, KNOB M4S		
33	XE0863051	WASHER,M6			77	X59629051	TAPTITE BIND B M3X10		
34	048040343	RETAINING RING E4			78	XG1479001	CYLINDER CONNECTION L		
35	X53838051	WASHER			79	XG1563001	CYLINDER CONNECTION R		
36	XG1595001	T BELT B60S656			80	061300616	SCREW FLAT M3X6		
37	XG1591001	X GUIDE SHAFT			81	XG2575001	LEAD WIRE ASSY INLET PWSW 120 (USA, CAN)		
38	021060206	NUT 2 M6				XG3162001	LEAD WIRE ASSY INLET PWSW 230 (OTHER)		
39	028060246	WASHER SPRING 2-6			82	XF6056001	X AREA PCB ASSY		
40	XF2146001	X CARRIAGE BX			83	XG2243001	Y AREA PCB ASSY		
41	XC5792051	BEARING CASE X ASSY			84	XF6057001	HOOP PCB ASSY		
42	048040343	RETAINING RING E4			85	XE7948001	CONNECT PCB ASSY		
43	XC6222001	BEARING 12 LINER		1000052910					
44	048210142	RETAINING RING, EXTERNAL C21							

(7) XYCARRIAGE MECHANISM

No.	CODE	NAME	R/H	REMARKS
86	XC6177051	ASSY: HOOP SENSOR		
87	XG2552001	PULSE MOTOR:X 17PU-H022BG01CN	H	
88	0A4300806	SCREW PAN (S/P WASHER) M3X8		
89	XE7940001	FLEXIBLE FLAT CABLE:SML2CD-YC		
90	XG2287001	FLEXIBLE FLAT CABLE:SML2CD-CX		
91	XG2280001	FLEXIBLE FLAT CABLE:SML2CD-XH		
92	XC6219151	X FRAME SPACER		
93	XE2281001	INSULATION SHEET		
94	XC3183051	FELT		
95	018300532	BOLT SOCKET M3X5		
96	XG2537001	TUBULARROUND ARM A SUPPLY ASSY		
97	XG1547001	TUBULAR ROUND ARM RA SET		
98	XC7076151	SPRING,PLATE		
99	XC7644051	SCREW, PAM (S/P WASHER) M3X5		
100	XG1548001	TUBULAR ROUND ARM LA SET		
101	XC7076151	SPRING,PLATE		
102	XC7644051	SCREW, PAM (S/P WASHER) M3X5		
103	XE7375001	SEAL		
104	XE7140001	GUIDE PLATE ASSY		
105	XE7143101	SPRING PLATE		
106	XG1480001	HOOP STAY A		
107	048030343	RETAINING RING E3		
108	XC5816051	RUBBER		
109	0A5400806	SCREW PAN (S/P WASHER) M4X8		
110	XE7146001	TUBULAR ARM COVER L2		
111	XC5553051	THUMB BOLT M4 L		
112	XE7174001	TUBULAR ARM COVER R2		
113	136681051	TAPTITE, BIND B M3X8		
114	XG2396001	SEAL A		
115	XG1618001	Y MOTOR ASSY	H	
116	XG1596001	Y BELT SUPPORT		
117	XC7644051	SCREW, PAM (S/P WASHER) M3X5		
118	XG1715001	FOOT CONTROLLER JACK ASSY		
119	052301606	SCREW, PAN (S/P WASHER) M3X16		
120	XG0870001	COATING CLIP		
121	XG3713001	CORD CLAMP:WL-1/4S		
122	XG3714001	CORD CLAMP:WL-5/16S		

(7) XYCARRIAGE MECHANISM

Blank page

www.SwasikSew.com

(8) LOWER SHAFT MECHANISM

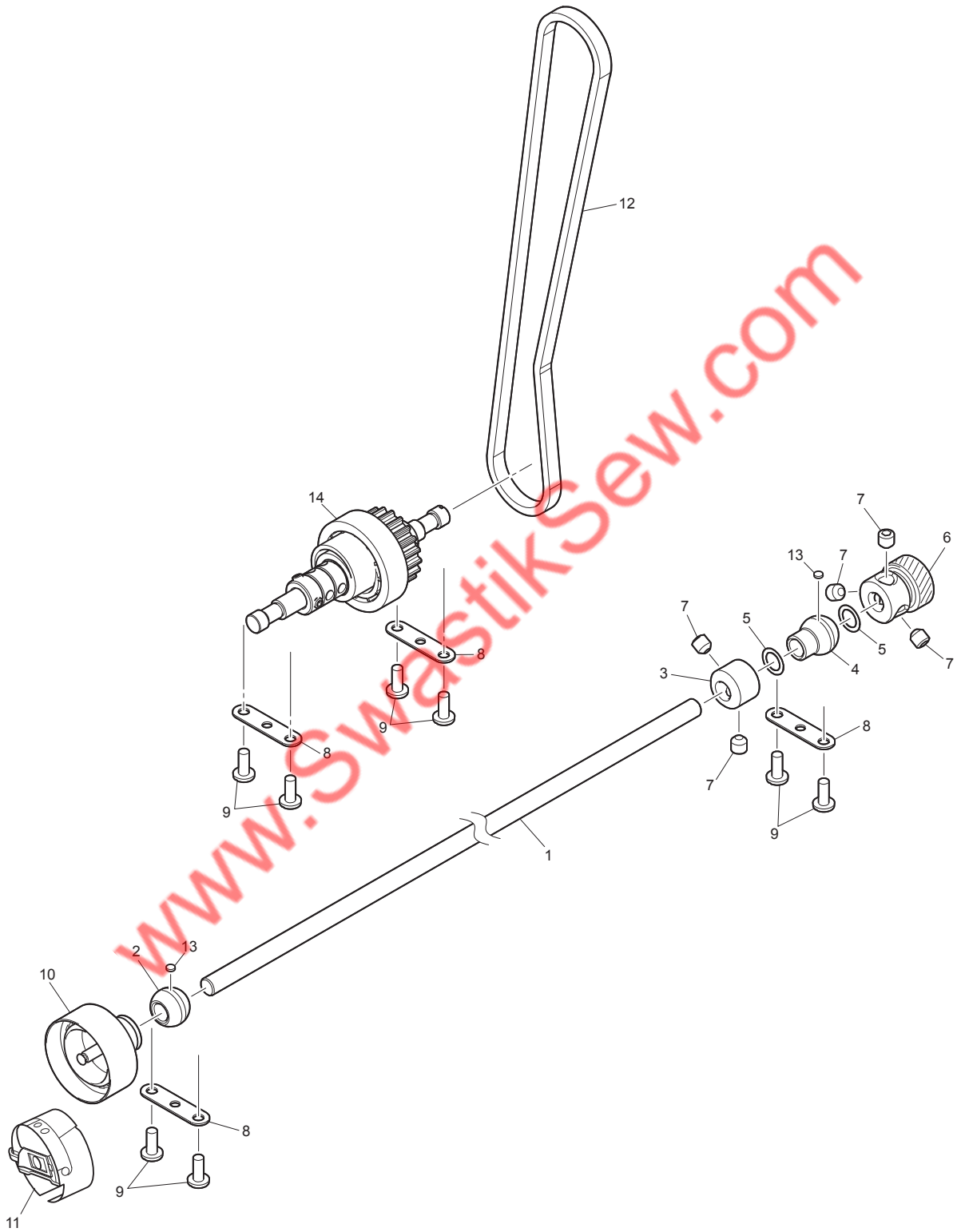

(9) THREAD CUTTING MECHANISM

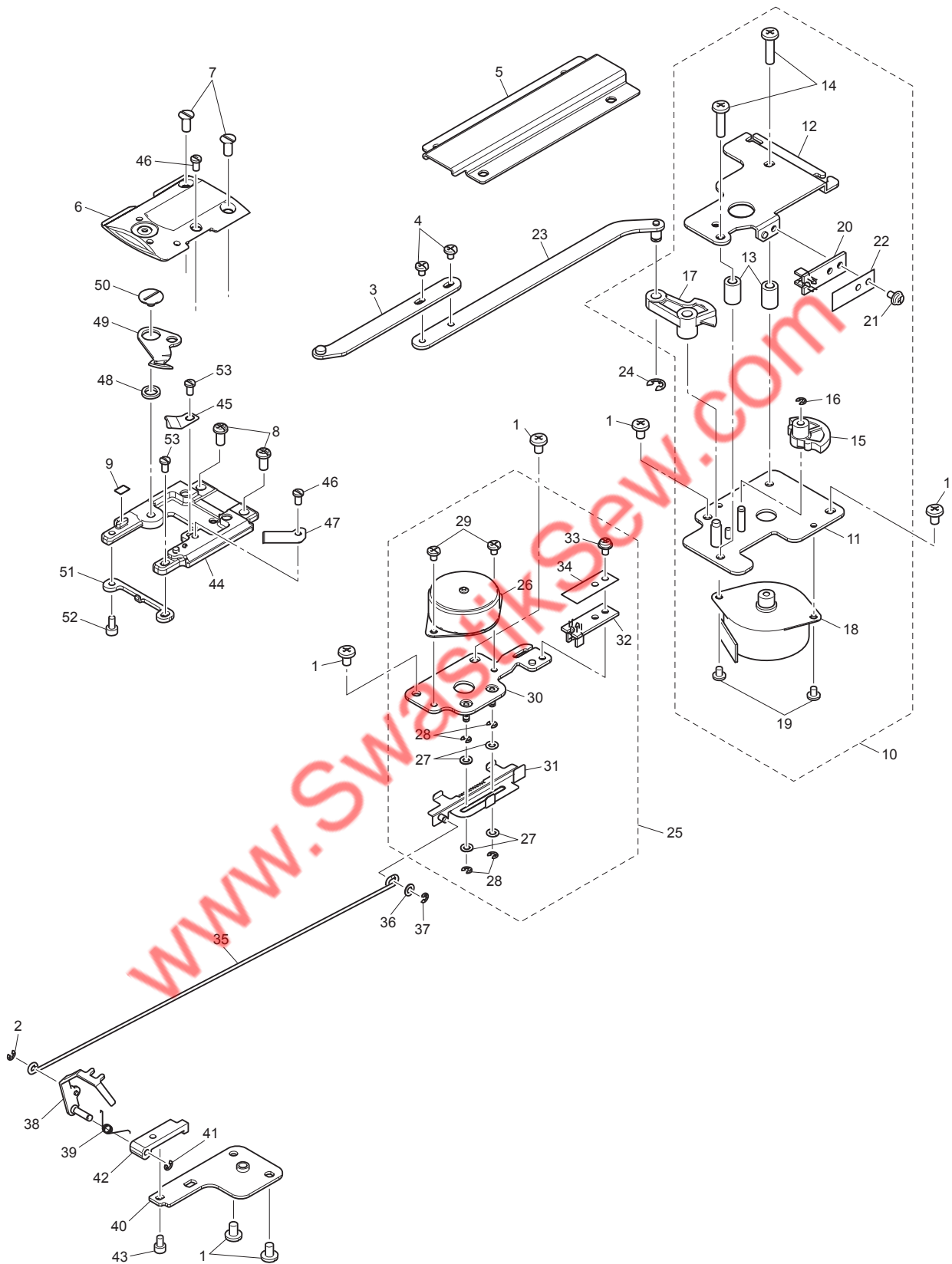

(9) THREAD CUTTING MECHANISM

No.	CODE	NAME	R/H	REMARKS	No.	CODE	NAME	R/H	REMARKS
1	060400616	SCREW BIND M4X6			43	018300532	BOLT SOCKET M3X5		
2	048020343	RETAINING RING E2			44	XC5876051	NEEDLE PLATE BASE ASSY		
3	XC5871151	CUTTER LINK ASSY			45	XC6230051	THREAD HOLDING PLATE		
4	060300416	SCREW BIND M3X4			46	XC5881051	SCREW		
5	XC5874051	BED COVER			47	XC5882051	FIXED KNIFE *	H	
6	XE1142001	NEEDLE PLATE	R		48	S32476001	COLLAR, M-KNIFE		
7	XC6404051	SCREW,FLAT M4			49	XC6908151	MOVABLE KNIFE SUPPLY ASSY *	H	
8	062400816	SCREW PAN M4X8			50	S32475001	SCREW, M4		
9	XC5984051	FELT			51	XC5879051	ROTARY HOOK STOPPER		
10	XG2851001	CUTTER UNIT COMPLETE			52	018300636	BOLT SOCKET M3X6		
11	XC5858151	CT MOTOR BRACKET ASSY			53	XC5881051	SCREW		
12	XC5863151	CUTTER BRACKET							
13	XC5864051	COLLAR							
14	000401605	SCREW BIND M4X16							
15	XC5865051	INITIAL GEAR							
16	048020343	RETAINING RING E2							
17	XC5866051	LEVER GEAR							
18	XG3137001	PULSE MOTOR:C M42SP-6N							
19	060300416	SCREW BIND M3X4							
20	XG3106001	TH CUTTER SENSOR PCB ASSY							
21	XC7564051	SCREW PAN(S/P WASHER)M3X6							
22	XE7791101	INSULATION SHEET							
23	XC5868051	LEVER LINK ASSY							
24	048040343	RETAINING RING E4							
25	XG2853001	PK MOTOR UNIT COMPLETE							
26	XG2548001	PULSE MOTOR:P M35SP-9NK							
27	026030136	WASHER PLAIN S 3							
28	048020343	RETAINING RING E2							
29	060300416	SCREW BIND M3X4							
30	XC5510151	PK MOTOR BRACKET ASSY							
31	XC5513151	RACK ASSY							
32	XG3112001	PICKER SENSOR PCB ASSY							
33	XC7564051	SCREW PAN(S/P WASHER)M3X6							
34	XE7791101	INSULATION SHEET							
35	XC5856051	PICKER LINK							
36	026030136	WASHER PLAIN S 3							
37	048020343	RETAINING RING E2							
38	XC5849151	PICKER ASSY							
39	XC5853051	PICKER SPRING	H						
40	XC5854051	PICKER BRACKET							
41	048020343	RETAINING RING E2							
42	XC6634151	PICKER HOLDER							

* Replacing the FIXED KNIFE(#47) and MOVABLE KNIFE SUPPLY ASSY(#49) simultaneously is recommended.

(10) UPPER THREADING MECHANISM

No.	CODE	NAME	R/H	REMARKS	No.	CODE	NAME	R/H	REMARKS
1	XG1765101	BOBBIN WINDER HOLDER ASSY			45	XC6619151	THREAD TENSIONER		
2	XC6607051	RUBBER			46	XC6620051	SHAFT		
3	XC6608151	THREAD GUIDE LEVER			47	XE4273001	BW GUIDE SPRING		
4	XG1767001	SWITCH LEVER ASSY			48	XC7566051	SCREW, PAN(S/P WASHER)M4X8		
5	048030343	RETAINING RING E3			49	048030343	RETAINING RING E3		
6	XA2401050	WASHER		1000051620	50	XG3415001	ROUTE INSTRUCTION LABEL		
7	XA9545051	SPRING			51	008400603	SCREW TRUSS M4X6		
8	XG1769001	BOBBIN WINDER MOTOR UNIT			52	XG4035001	CUTTER COVER FIX PLATE		
9	XA5876051	BOBBIN BASE ASSY			53	061300616	SCREW FLAT M3X6		
10	X80321001	NT LOWER THREAD CUTTER			54	0A5401006	SCREW PAN (S/P WASHER) M4X10		
11	XA5877051	BOBBIN THREAD CUTTER HOLDER			55	XG4023001	ANTENNA D ASSY		
12	XE4465001	BW SWITCH ASSY			56	060400616	SCREW BIND M4X6		
13	XC8194051	BW SWITCH HOLDER							
14	XG1757001	BOBBIN PRESSER COVER							
15	XC7564051	SCREW PAN(S/P WASHER)M3X6							
16	060300416	SCREW BIND M3X4							
17	XG2561001	LEAD WIRE ASSY BW							
18	XG1631001	SPOOL STAND FRAME							
19	XC5949051	SPOOL PIN							
20	XG1713001	SPONGE							
21	XG2488001	ANTENNA PLATE ASSY							
22	XG1636001	CUTTER COVER							
23	X80321001	NT LOWER THREAD CUTTER							
24	138384051	RETAINING RING,CS5							
25	XG3147001	CUTTER COVER PLATE ASSY							
26	XC5947051	NEEDLE THREAD PRESSER PLATE							
27	XG1638001	NEEDLE THREAD PRESSER PLATE							
28	XC5962051	SPRING							
29	048015343	RETAINING RING E1.5							
30	085310816	TAPTITE BIND B M3X8							
31	XG1636001	CUTTER COVER							
32	X80321001	NT LOWER THREAD CUTTER							
33	138384051	RETAINING RING,CS5							
34	XG3641001	CUTTER COVER PLATE2 ASSY							
35	XC5947051	NEEDLE THREAD PRESSER PLATE							
36	XG1638001	NEEDLE THREAD PRESSER PLATE							
37	XC5962051	SPRING							
38	048015343	RETAINING RING E1.5							
39	085310816	TAPTITE BIND B M3X8							
40	XG1792001	ANTENNA STAND							
41	XG2489001	TENSION GUIDE PLATE							
42	060300616	SCREW BIND M3X6							
43	XE4272001	BW GUIDE COVER							
44	XE4163001	TENSION GUIDE PLATE							

(11) ACCESSORY PARTS

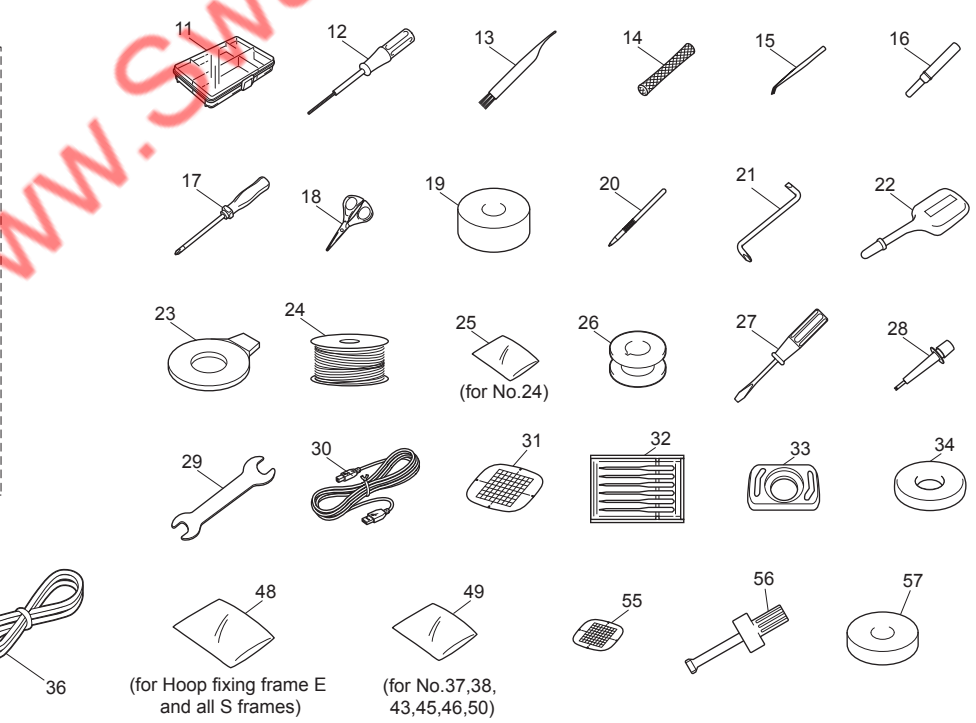
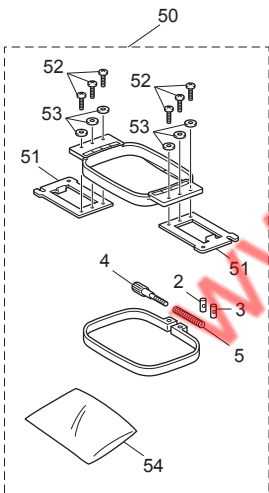
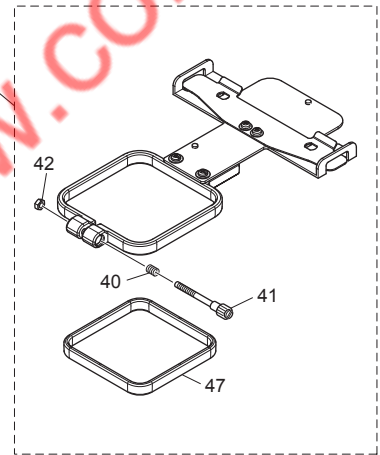
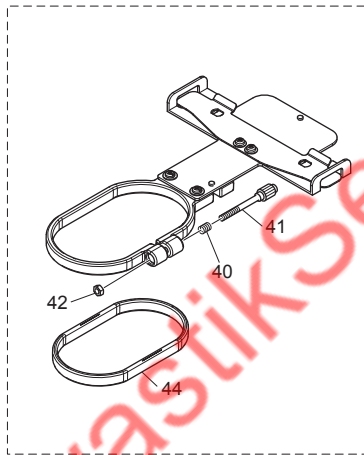
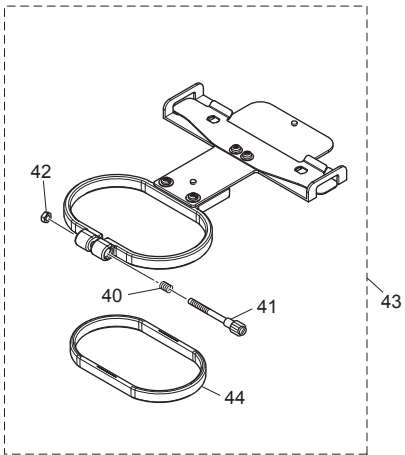
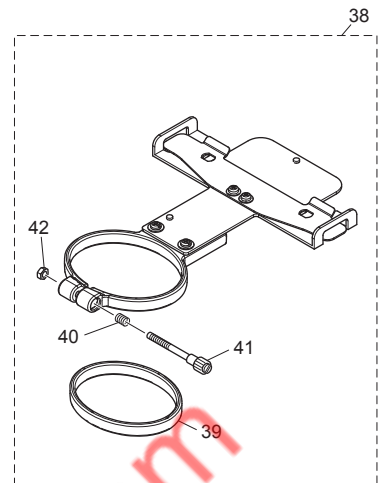
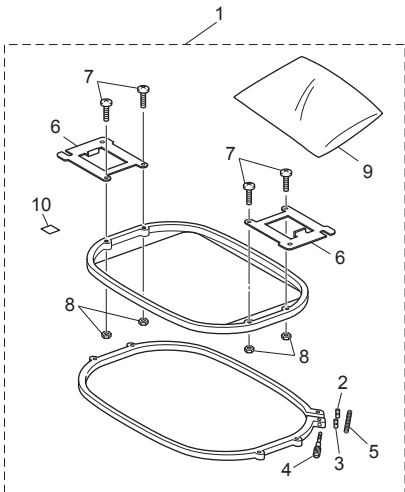

(for Hoop fixing frame E and all S frames)

(for No. 37, 38, 43, 45, 46, 50)

(11) ACCESSORY PARTS

No.	CODE	NAME	R/H	REMARKS	No.	CODE	NAME	R/H	REMARKS
1	ACC	TUBULAR FRAME 20X20 ASSY							
2	S32798001	COLLAR				XD0111151	POWER SUPPLY CORD:IRAM (ARG)		
3	S32799001	NUT, M4				XE2016001	POWER SUPPLY CORD:KOR (KOR)		
4	XC5957051	SCREW, M4				XA0070151	POWER SUPPLY CORD (OTHER)		
5	S36043000	SPRING, COMPRESSION 5.3X47.7			37	XG2408001	HOOP FIXING FRAME E SET		
6	XG1492001	HOLDER 20X20			38	ACC	S FRAME 44 ASSY		
7	062401416	SCREW PAN M4X14			39	XG2414001	S FRAME 44 INNER HOOP		
8	021400206	NUT 2 M4			40	XG1789001	SPRING COMPRESSION		
9	X60224051	BAG 350X700H			41	XG1790001	KNOB SCREW M3.5		
10	XG2396001	SEAL A			42	021350213	NUT 2 M3.5		
11	XC6482051	ACCESSORY CASE			43	ACC	S FRAME 70 ASSY		
12	XC5159051	HEXAGONAL DRIVER,1.5			44	XG2421001	S FRAME 70 V INNER HOOP		
13	X59476051	CLEANING BRUSH			45	ACC	S FRAME V ASSY		
14	S34455000	NET, 160L			46	ACC	S FRAME 50 ASSY		
15	XC6542051	PINCETTE			47	XG2432001	S FRAME 50 INNER HOOP		
16	XF4967001	RIPPER ASSY			48	XF3666001	BAG 230X340H		
17	XC6543051	SCREW DRIVER, 2X100			49	XC4515050	BAG, BUBBLE PACK 250X250		
18	XF2052001	SCISSORS			50	ACC	TUBULAR FRAME 10X10 ASSY		
19	XC5974151	BOBBIN TENSION GAUGE			51	XC5968051	HOLDER 10X10		
20	XA9940051	TOUCH PEN			52	060300516	SCREW BIND M3X5		
21	XC6545051	Z-TYPE SCREW-DRIVER, +-			53	025030236	WASHER PLAIN M 3		
22	XG3677001	OILER SUPPLY ASSY (EUROPE, TUR, KOR)			54	XZ0197051	BAG 180X470		
	XZ0206051	OILER B ASSY (OTHER)			55	XC5759051	EMBROIDERY SHEET 10X10 ASSY		
23	XC1074051	DISC-SHAPED SCREWDRIVER			56	XC4237021	DRIVER ASSY		
24	XC6368051	BOBBIN (Pre-wound paper bobbin)			57	XC6631051	BOBBIN TENSION GAUGE 45G		
25	X60838051	BAG,70X110C							
26	100376051	BOBBIN (Unwound steel bobbin)							
27	X55468051	SCREW DRIVER S							
28	XF2212001	NEEDLE EXCHANGE TOOL							
29	XC6159051	WRENCH 13X10							
30	XD1851051	USB I/F CORE CABLE 3M							
31	XE7171001	EMBROIDERY SHEET 20X20 ASSY							
32	XC6469001	NEEDLE ASSEMBLY							
33	XC6499151	NEEDLE PLATE COVER							
34	XC7134051	SPOOL FELT							
35	130012054	SPOOL PRESSER A							
36	XC6052151	POWER SUPPLY CORD:UL CSA-LF (USA, CAN)							
	XC9548051	POWER SUPPLY CORD:SAA-LF (AUS&NZL)							
	XF5050001	POWER SUPPLY CORD:BRZ (BRA)							
	X59354251	POWER SUPPLY CORD BS (UK&IRE, MYS, HKG, SGP)							
	XF7409001	POWER SUPPLY CORD:CHN (CHN)							

(12) PACKAGE / USER MANUAL

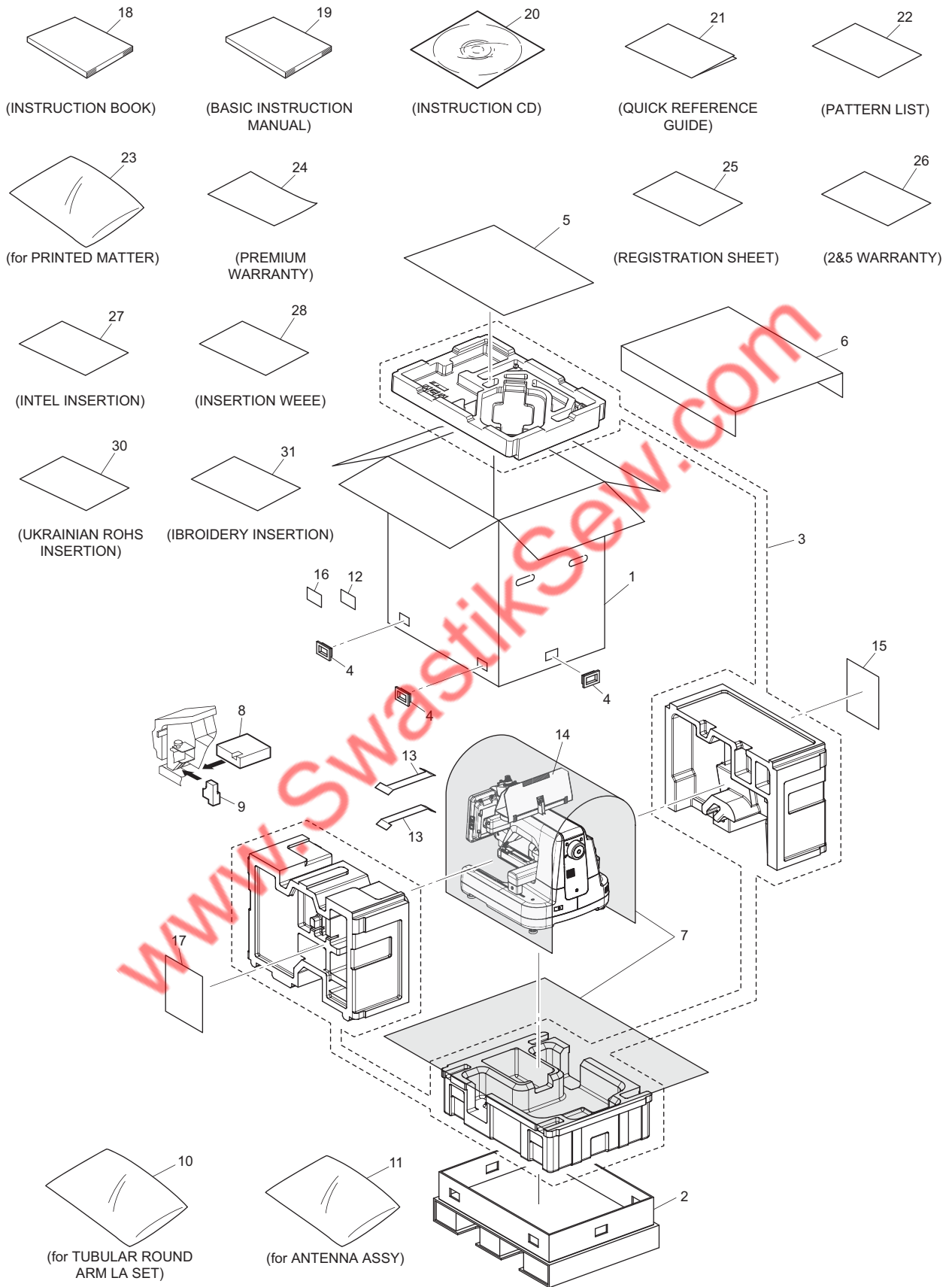

(12) PACKAGE / USER MANUAL

No.	CODE	NAME	R/H	REMARKS	No.	CODE	NAME	R/H	REMARKS
PACKING MATERIALS					20	XG4072101	INSTRUCTION CD E/G/F/D/I/S (DEU, UK&IRE, ESP)		1000053682
1	XG2382101	CARTON TOP:MODEL E1 (PRS100)	R	1000051826	21	XG1498001	QUICK REFERENCE GUIDE (USA, CAN, BRA, AUS&NZL, CHL&PER, MYS, VNM&IND&PHL&SGP&THA&MMR, ARG, PRY, IND)	R	
	XG3265101	CARTON TOP:MODEL VR (VR)	R	1000051826		XG3355001	QUICK REFERENCE GUIDE ASIA (RUS, HKG, CHN, KOR)	R	
2	XG2490001	CARTON BOTTOM ASSY	R			XG3357001	QUICK REFERENCE GUIDE ARB (UAE)	R	
3	XG2384001	POLYSTYRENE FOAM PAD ASSY T51	R		22	XG3264001	PATTERN LIST (DEU)		
4	XC5848051	JOINT				XG3766001	PATTERN LIST ASIA (RUS, HKG, CHN, KOR)		
5	XG2497001	CARTON PAD ACC	R			XG1506001	PATTERN LIST (OTHER)		
6	XG2498001	CARTON PAD TOP	R		23	X50902051	BAG 350X470H		
7	XC6459051	SHEET 1400X2000			24	XF2705101	PREMIUM WARRANTY FOR US (USA)		
8	XG1585001	POLYSTYRENE FOAM PAD FOOT	R			XE7726101	WARRANTY CARD (CAN)		
9	XC7140150	HOOK SUPPORT SF	R			XG6840001	WARRANTY CARD BRO BR HEM (BRA)		1000053985
10	X60224051	BAG 350X700H			25	XE9639001	REGISTRATION SHEET (USA)		
11	X50902051	BAG 350X470H			26	XF6323101	2&5 WARRANTY FOR US (USA)		
12	XF0905101	IBROIDERY STICKER			27	XF5561001	INTEL INSERTION (BRA)		1000053020
13	XE7435001	X CARRIAGE PAD	R		28	XF0300101	INSERTION WEEE		
14	XG3747001	ANTENNA PROTECT PAD	R		29	XG3263001	INSERTION WEB (DEU, UK&IRE, ESP)		1000053682
15	XG4083001	PAD	R		30	XE9897001	UKRAINIAN ROHS INSERTION (RUS)		
16	XG2534001	CLEAR LABEL (BRA, AUS&NZL)			31	XG4337001	IBROIDERY INSERTION 3 D		1000051564
	XF7001001	CLEAR LABEL (AUS&NZL)				XG4208001	ADDRESS LABEL BR BITW		1000051957
	XE7439001	CLEAR LABEL (OTHER)				XG4212001	WARRANTY LABEL BR 90DAYS		1000051957
17	XF5871001	MFFC PAD		1000051622		XG4492001	NEEDLE INSERTION E1		1000053682
PRINTED MATTER									
18	XG1496101	INSTRUCTION BOOK ENG (English)	R	1000053682					
	XG1497101	INSTRUCTION BOOK SPA (Spanish)	R	1000053682					
	XG3351101	INSTRUCTION BOOK FRA (French)	R	1000053682					
	XG1529001	INSTRUCTION MANUAL BR (Portuguese)	R						
	XG3348101	INSTRUCTION BOOK RUS (Russian)	R	1000053682					
	XG3356001	INSTRUCTION BOOK ARB (Arabic)	R						
	XG3353001	INSTRUCTION BOOK TC (HKG: Chinese)	R						
	XG3352001	INSTRUCTION BOOK SC (Chinese)	R						
	XG3354001	INSTRUCTION BOOK KOR (KOR)	R						
19	XG3252101	BASIC INSTRUCTION MANUAL ENG (English)	R	1000053682					
	XG3253101	BASIC INSTRUCTION MANUAL GER (German)	R	1000053682					
	XG3254101	BASIC INSTRUCTION MANUAL FRE (French)	R	1000053682					
	XG3255101	BASIC INSTRUCTION MANUAL DUT (Dutch)	R	1000053682					
	XG3256101	BASIC INSTRUCTION MANUAL ITA (Italian)	R	1000053682					
	XG3257101	BASIC INSTRUCTION MANUAL SWE (Swedish)	R	1000053682					
	XG3258101	BASIC INSTRUCTION MANUAL DEN (Danish)	R	1000053682					
	XG3259101	BASIC INSTRUCTION MANUAL CZE (Czech)	R	1000053682					
	XG3260101	BASIC INSTRUCTION MANUAL POL (Polish)	R	1000053682					
	XG3261101	BASIC INSTRUCTION MANUAL HUN (Hungarian)	R	1000053682					
	XG3262101	BASIC INSTRUCTION MANUAL ROM (Romanian)	R	1000053682					
	XG3347101	BASIC INSTRUCTION BOOK SPA (Spanish)	R	1000053682					

SPARE PARTS

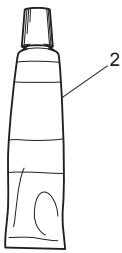
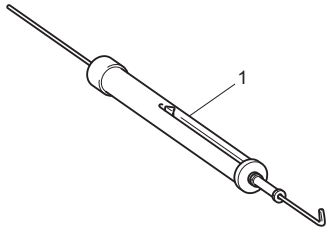

www.SwastikSew.com

brother

www.SwastikaSew.com