

# **Auto-Sharpening Cutting Machine**

**Instruction Manual  
And parts list**

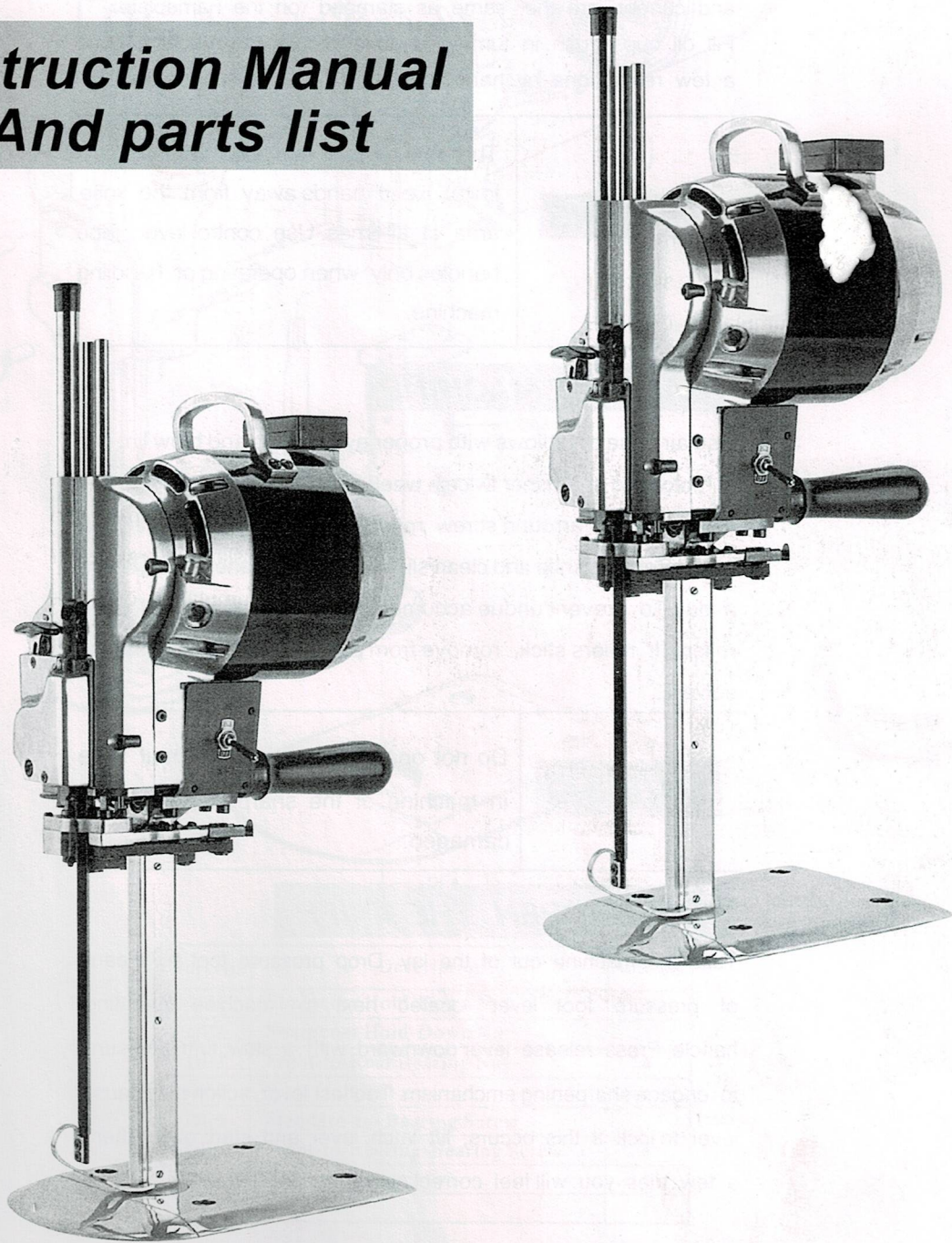

## **Operation, Lubrication and care**

Before operating machine, read this page carefully.

Before operating the motor, be sure that electric supply voltage and current are the same as stamped on the nameplate. Fill oil cup. Push in turning knob and turn the machine over a few revolutions by hand to see if the knife moves easily.

### **WARNING**

This machine is equipped with a sharp knife. Keep hands away from the knife area at all times. Use control levers and handles only when operating or handling machine.

### **CARE OF MACHINE**

Use air hose or bellows with proper eye shields and blow lint out of motor and sharpener twice a week. Remove cover over cam and clean out lint around screw mechanism in sharpener once a week. Remove knife and clean slides with slot cleaner at least once a day. To prevent undue accumulation of lint, do not oil plate rollers. If rollers stick, remove from plate and wash in cleaning solvent.

### **WARNING**

Do not operate sharpener without knife in machine or the sharpener will be damaged.

### **TO SHARPEN THE KNIFE**

Take the machine out of the lay. Drop pressure foot by means of pressure foot lever located next to machine operating handle. Press release lever downward with a slow, firm pressure to engage sharpening mechanism. Too fast lever action may cause lever to lock. If this occurs, lift latch lever and start over. After a few tries you will feel correct operating pressure.

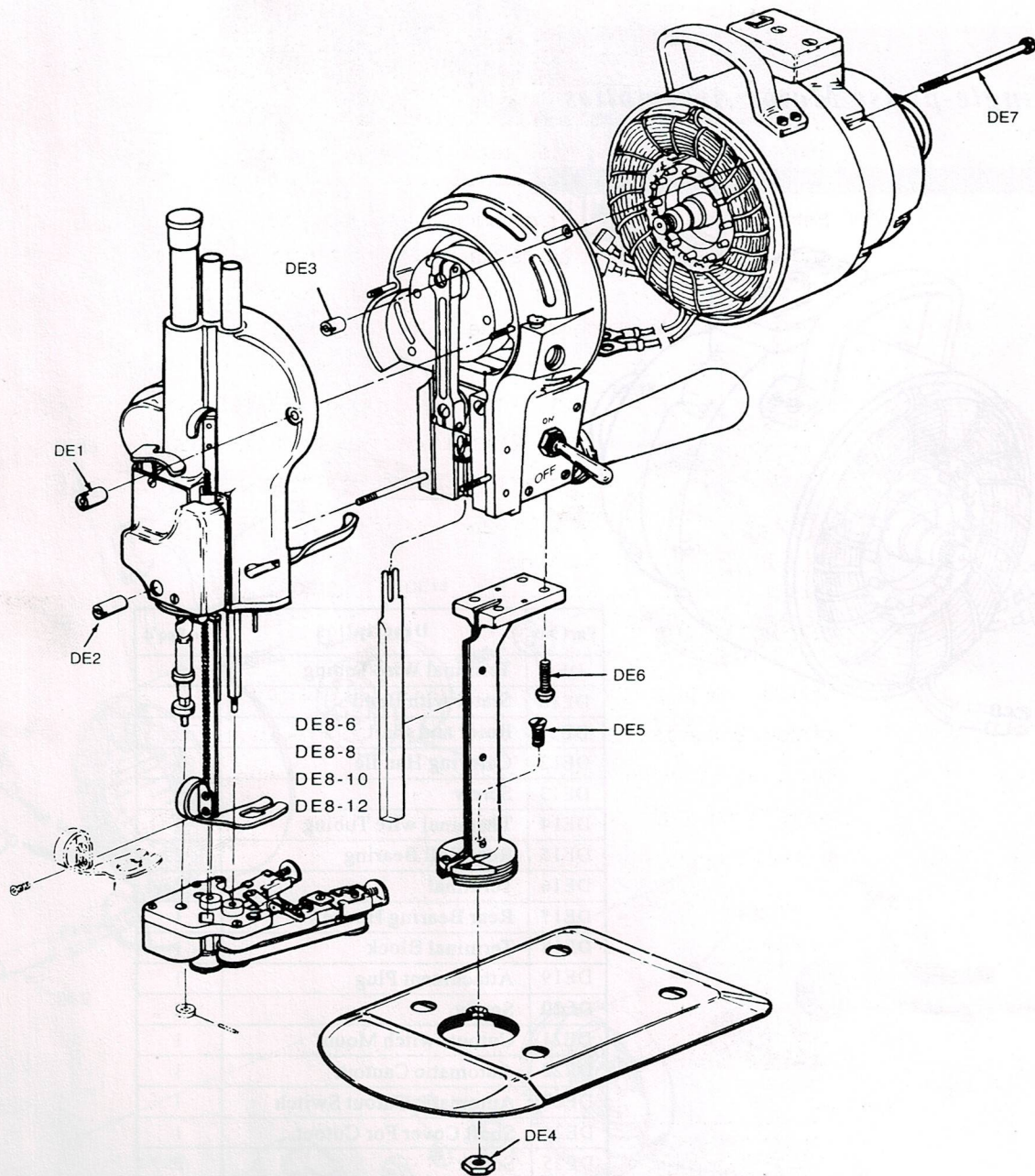

Part NO.	Description	No. Req'd
DE1	Sharpener Hold-Down Nut	3
DE2	Sharpener Hold-Down Nut	1
DE3	Front-to-Rear Bearing Nut	4
DE4	Plate Bolt Nut	1
DE5	Standard-to- Bearing Screw	1
DE6	Front-to-Rearing-Bearing Screw	4
DE7	Screw	4
DE8	Knife	1

## Single-phase Motor Assemblies

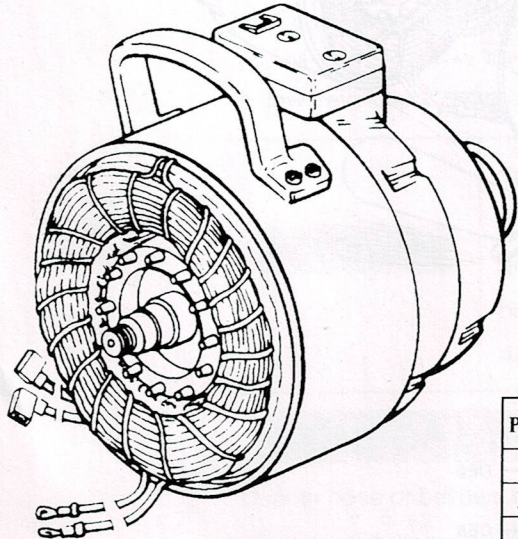

Part NO.	Description	No. Req'd
DE9	Terminal Wire Tubing	1
DE10	Stator with Band	1
DE11	Rotor and shaft	1
DE12	Carrying Handle	1
DE13	Screw	4
DE14	Terminal wire Tubing	1
DE15	Rear Ball Bearing	2
DE16	Terminal	2
DE17	Rear Bearing House	1
DE18	Terminal Block	1
DE19	Attachment Plug	1
DE20	Screw	2
DE21	Cutout switch Mount	1
DE22	Automatic Cautout	1
DE23	Automatic Cutout Switch	1
DE24	Shaft Cover For Cutout	1
DE25	Screw	2
DE26	Screw	2
DE27	Cover for Cutout	1
DE28	Rotor Fan	1
DE29	Leading spring Washer	1
DE30	Clutch Nut	1
DE31	Retaining Ring	1
DE32	Fan Cover	1
DE33	Screw	2
DE34	Clutch Spring	1
DE35	Turning Knob	1

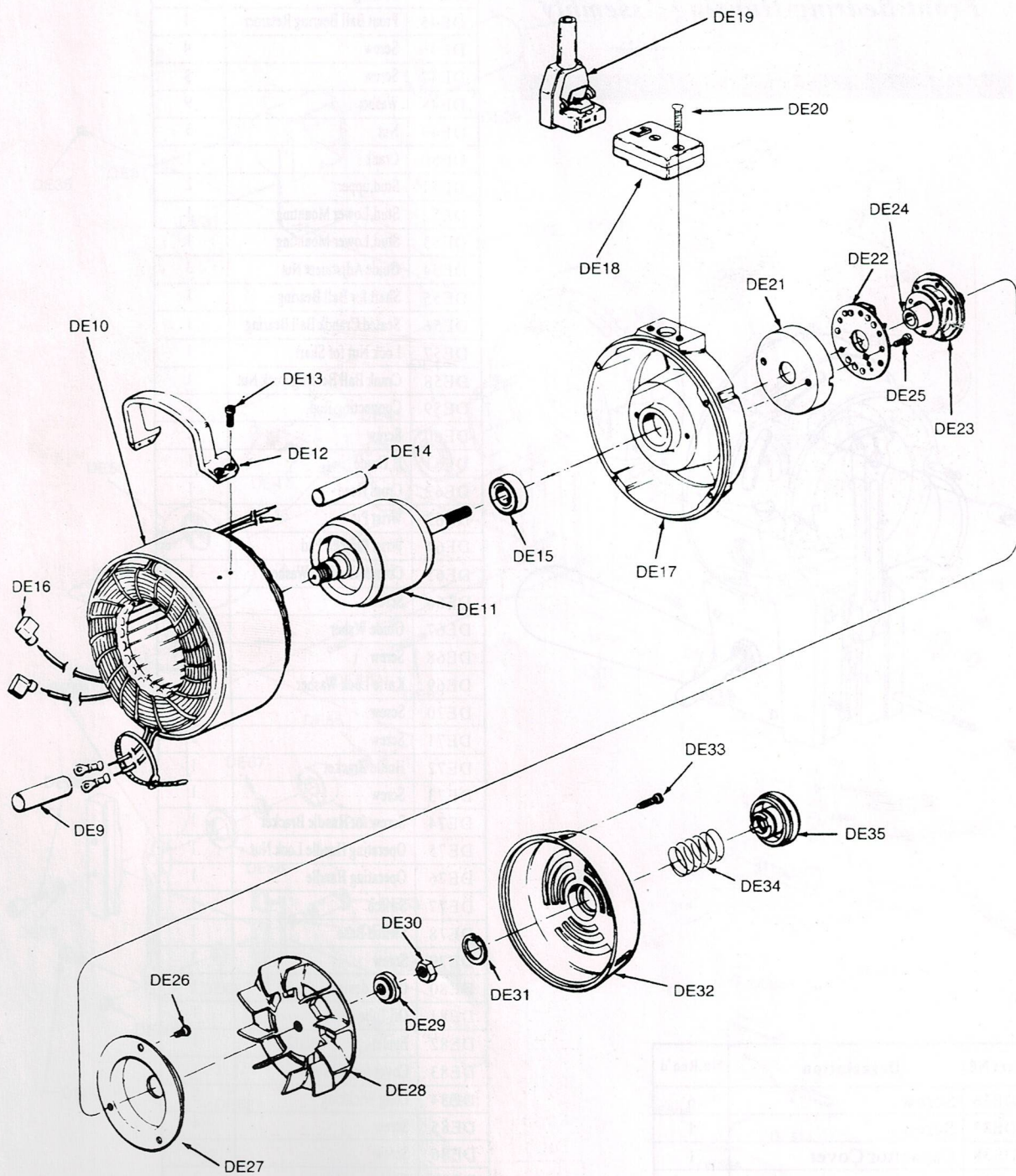

## Front Bearing Housing Assembly

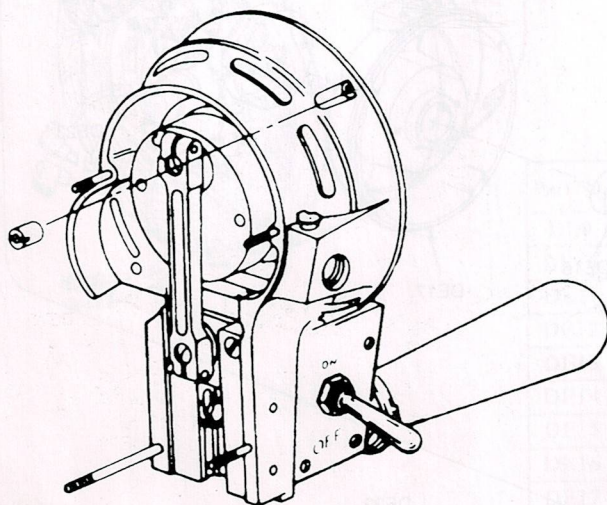

Part NO.	Description	No. Req'd
DE36	Screw	6
DE37	Screw	1
DE38	Capacitor Cover	1
DE39	Capacitor	1
DE40	Cover for Capacitor	1
DE41	Spring for Capacitor	1
DE42	Shaft Lock Nut	1

Part NO.	Description	No. Req'd
DE43	Front Bearing Housing	1
DE44	Bearing	1
DE45	Front Ball Bearing Retainer	1
DE46	Screw	4
DE47	Screw	3
DE48	Washer	9
DE49	Nut	3
DE50	Crank	1
DE51	Stud, upper	2
DE52	Stud, Lower Mounting	1
DE53	Stud, Lower Mounting	1
DE54	Guide Adjustment Nut	3
DE55	Shaft for Ball Bearing	1
DE56	Seated Crank Ball Bearing	1
DE57	Lock Nut for Shaft	1
DE58	Crank Ball Bearing Lock Nut	1
DE59	Connecting Rod	1
DE60	Screw	2
DE61	H. Guide	1
DE62	Cross Head	1
DE63	Wrist Pin	1
DE64	Wrist Pin Felt Pad	1
DE65	Connecting Rod Washer	1
DE66	Screw	1
DE67	Guide Washer	1
DE68	Screw	6
DE69	Knife Lock Washer	1
DE70	Screw	1
DE71	Screw	2
DE72	Handle Bracket	1
DE73	Screw	1
DE74	Screw for Handle Bracket	1
DE75	Operating Handle Lock Nut	1
DE76	Operating Handle	1
DE77	Switch	1
DE78	Switch Base	1
DE79	Screw	3
DE80	Oiling device	1
DE81	Oil Tube	1
DE82	Eyelet	1
DE83	Cover for Oil Tube	1
DE84	Long Wicking	3
DE85	Screw	4
DE86	Screw	2
DE87	Circle	2
DE88	Windows for oil	1
DE89	Oil tube cover	1
DE90	Oil Hole Cover	1

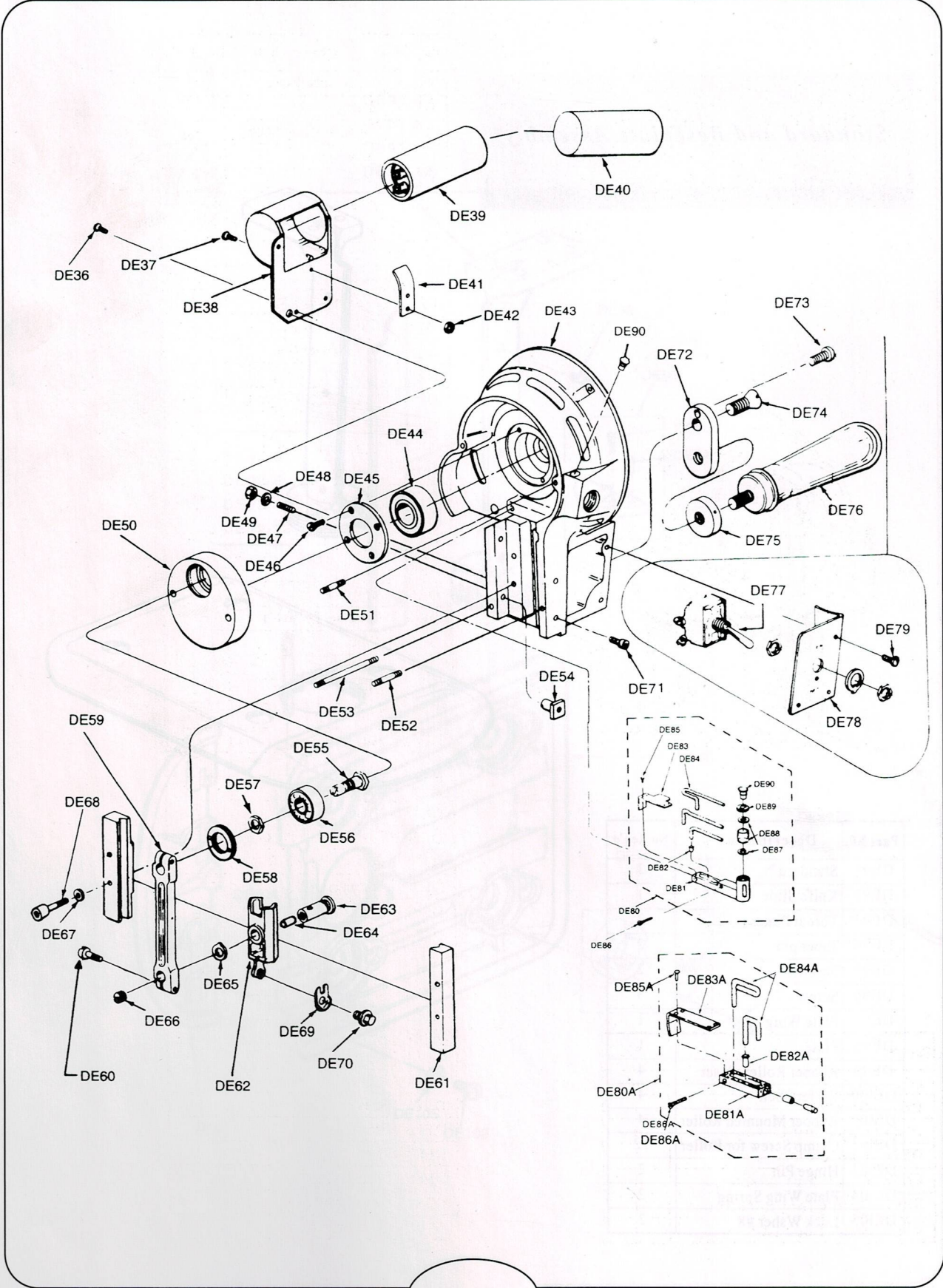

## Standard and Baseplate Assembly

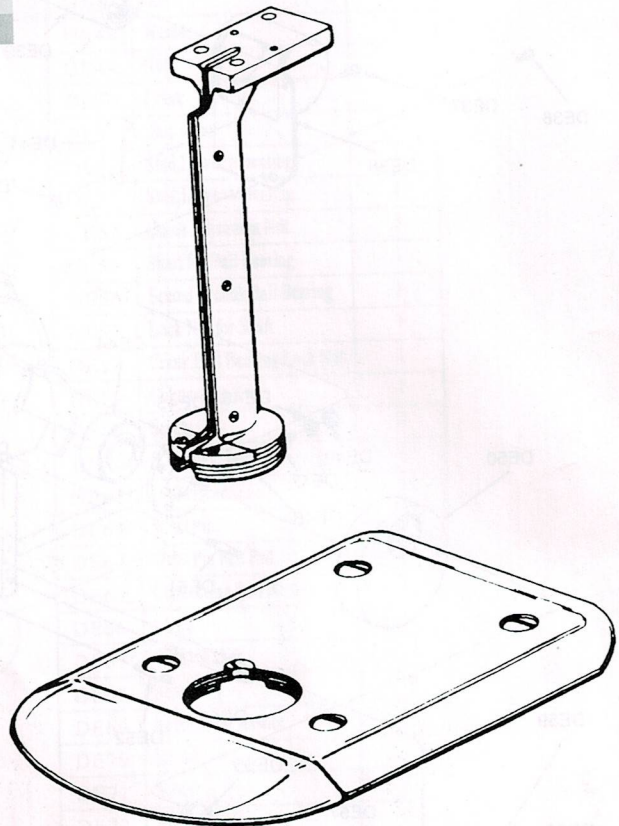

Part NO.	Description	No. Req'd
DE91	Standard	1
DE92	Knife Slide	1
DE93	Throat Plates	2
DE94	Taper pin	2
DE95	Screw	2
DE96	Screw	3
DE97	Plate Wing	1
DE98	Plate	1
DE99	Rubber Roller all set	4
DE100	Roller Shell	4
DE101	Rubber Mounted Roller	4
DE102	Clamp Screw for Roller	12
DE103	Hinge Pin	2
DE104	Plate Wing Spring	2
DE105	Lock Wsher.#8	2



DE91-6"  
DE91-8"  
DE91-10"  
DE91-12"

DE92-6"  
DE92-8"  
DE92-10"  
DE92-12"

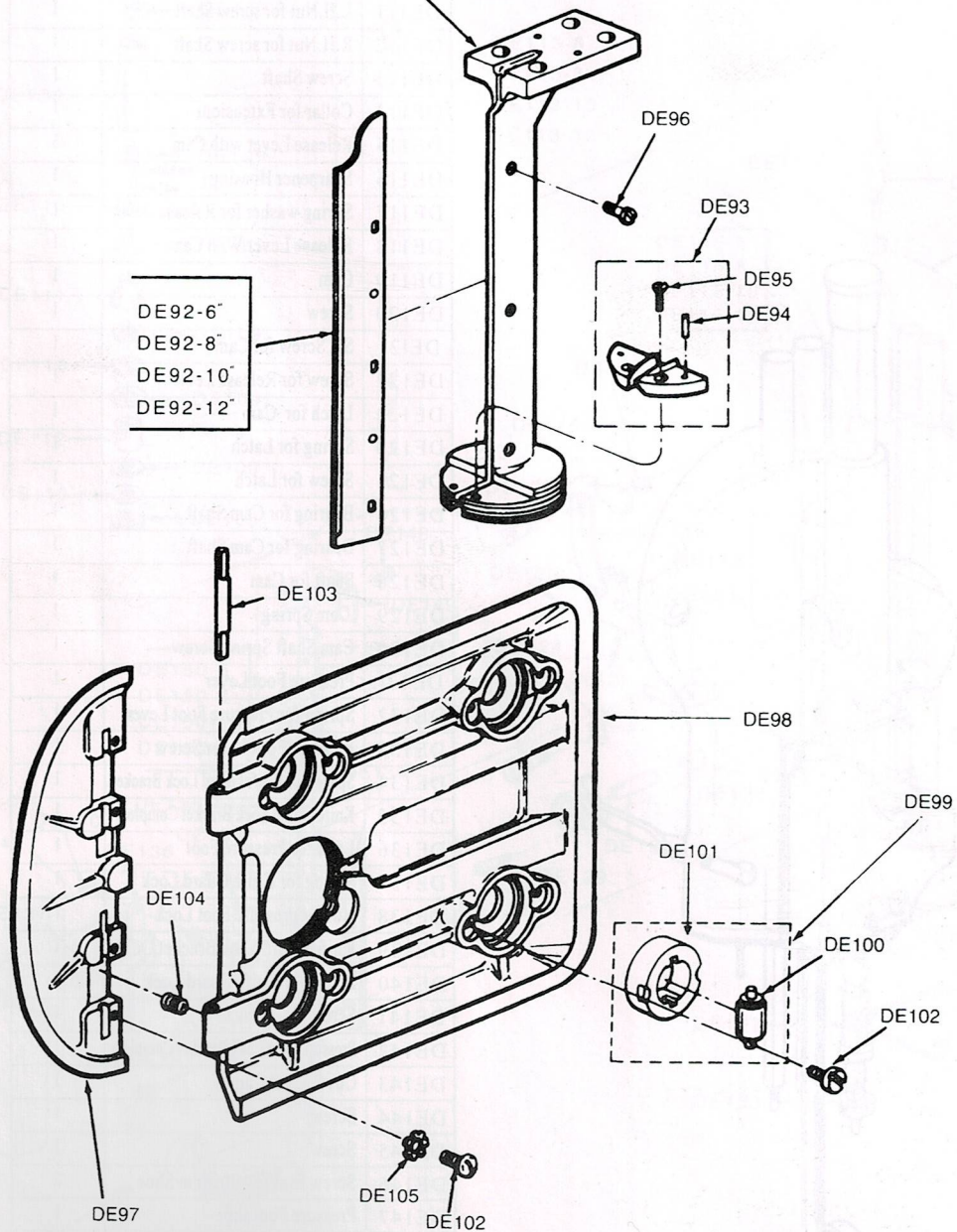

## Front Sharpener Housing Assembly

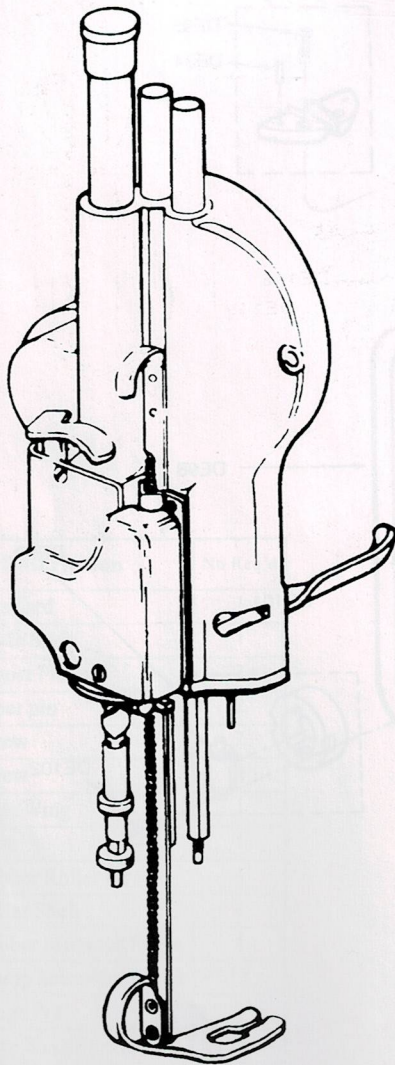

Part NO.	Description	No. Req'd
DE106	Cap of Tube	1
DE107	Stop Nut for Screw Shaft	1
DE108	Nut for Screw Shaft	1
DE109	Thrust washer for Nuts	3
DE110	Thrust Ball Bearing	3
DE111	L.H.Nut for screw Shaft	1
DE112	R.H.Nut for screw Shaft	1
DE113	Screw Shaft	1
DE114	Collar for Fxtension	1
DE115	Release Lever with Cam	1
DE116	Sharpener Housing (With Bushings and Tubes)	1
DE117	Spring washer for Release Lever	1
DE118	Release Lever With Cam	1
DE119	Cam	1
DE120	Screw	1
DE121	Set Screw for Cam	1
DE122	Screw for Release Lever	1
DE123	Latch for Cam	1
DE124	Spring for Latch	1
DE125	Screw for Latch	1
DE126	Bearing for Cam Shaft	1
DE127	Bearing for Cam Shaft	1
DE128	Shaft for Cam	1
DE129	Cam Spring	1
DE130	Cam Shaft Spring Screw	1
DE131	Pressure Foot Lever	1
DE132	Spring for Pressure Foot Lever	1
DE133	Pressure Foot Lever Screw	1
DE134	Spacer for Knife Guard Lock Bracket	1
DE135	Knife Guard Lock Bracket Complete	1
DE136	Lock for Pressure Foot	1
DE137	Spring for Knife Guard Lock	1
DE138	Nut for pressure Foot Lock	1
DE139	Knife Guard Lock Bracket Only	1
DE140	Screw for Knife Guard Lock	1
DE141	Screw	4
DE142	Pressure Foot Lock Bracket Complete	1
DE143	Cover Over Cam	1
DE144	Screw	1
DE145	Screw	1
DE146	Screw for Pressure Foot Shoe	2
DE147	Pressure Foot shoe	1
DE148	Screw	2
DE149	Lift Handle for Knife Guard Rod	1
DE150	Knife Guard Rod	1

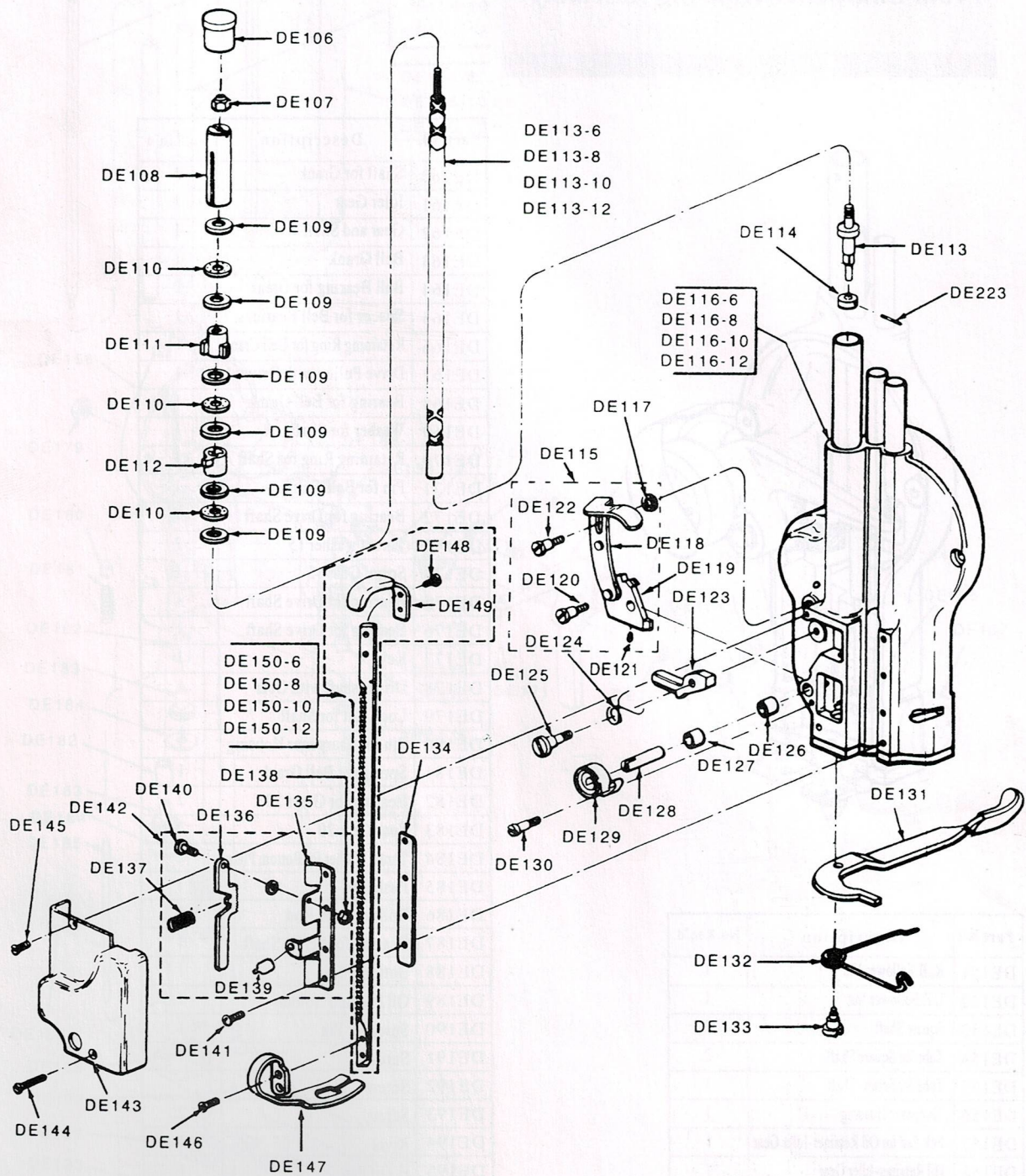

## Front Sharpener Housing Assembly

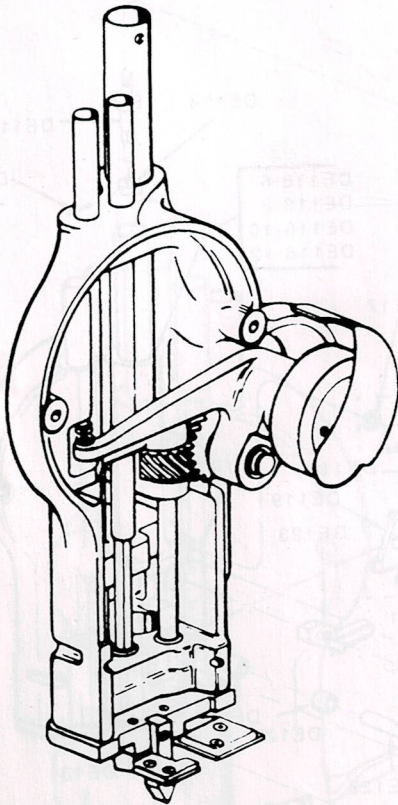

Part NO.	Description	No. Req'd
DE151	R.H.Follower Nut	1
DE152	L.H.Follower Nut	1
DE153	Square Shaft	2
DE154	Tube for Square Shaft	2
DE155	Tube for Screw Shaft	1
DE156	Sharpener Housing	1
DE157	Felt Pad for Oil Retainer-Idler Gear	1
DE158	Oil Retainer-Idler Gear	1
DE159	Screw	2

Part NO.	Description	No. Req'd
DE160	Shaft for Grank	1
DE161	Idler Gear	1
DE162	Gear and Shaft	1
DE163	Bell Grank	1
DE164	Ball Bearing for Grank	2
DE165	Spacer for Bell Bearings	1
DE166	Retaining Ring for Bell Crank	1
DE167	Drive Pulley with Driver	1
DE168	Bearing for Bell Grank	1
DE169	Washer for Shaft	1
DE170	Retaining Ring for Shaft	1
DE171	Pin for Bell Grank	1
DE172	Bearing for Drive Shaft	1
DE173	Thrust washer 15	2
DE174	Spiral Gear 15	1
DE175	Bearing for Drive Shaft	1
DE176	Bearing for Drive Shaft	1
DE177	Key	1
DE178	Driver shaft with Gear	1
DE179	Lock Nut for Shaft	1
DE180	Pin for Sharpener Housing	1
DE181	Spring for Bell Grank	1
DE182	Bearing for Gears 20	2
DE183	Spur Gear 20	2
DE184	Thrust Washer for Bottom Plate	2
DE185	Push Rod	1
DE186	Roll for Push Rod	1
DE187	Bearing for Screw Shaft	1
DE188	Bottom Plate	1
DE189	Oil Pad and Holder	1
DE190	Spreader Pin	1
DE191	Screw	1
DE192	Screw	3
DE193	Screw	2
DE194	Rivet	4
DE195	H.Oil Pad	1

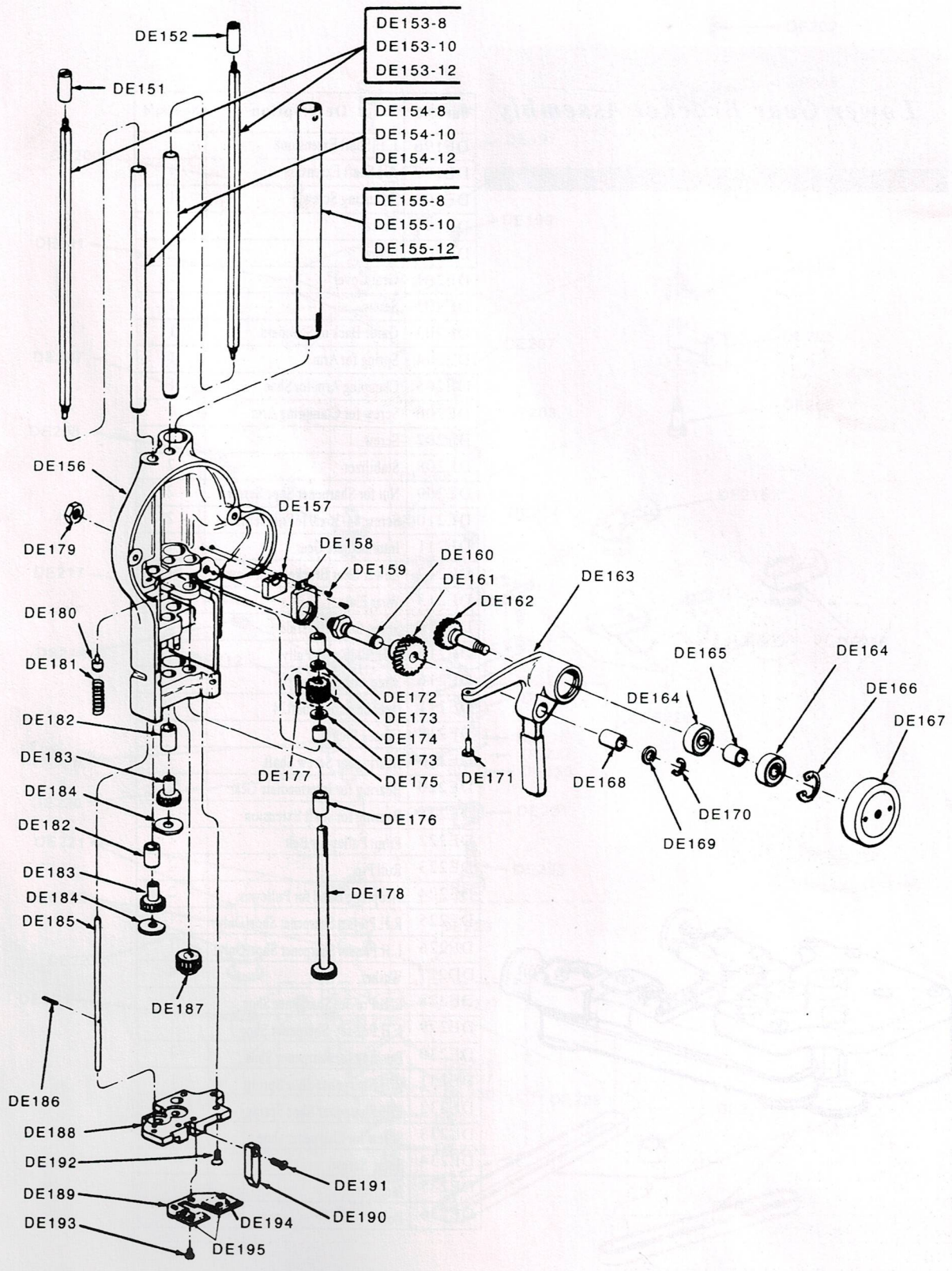

## Lower Gear Bracket Assembly

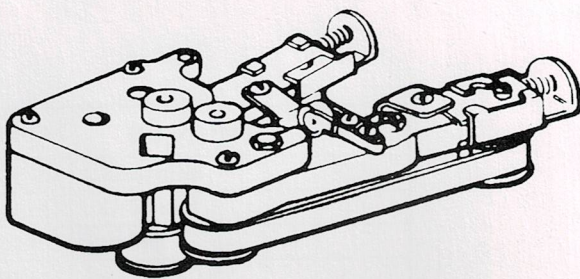

Part N0	Description	No. Req'd
DE196	L.H. Shaft Extension <sup>8</sup>	1
DE197	RH. Shaft Extension	1
DE198	Adjusting Screw	1
DE199	Screw	1
DE200	Screw	3
DE201	Gear Cover	1
DE202	Screw	2
DE203	Guide Back of Standard	1
DE204	Spring for Arm	1
DE205	Clamping Arm for Shoe	1
DE206	Screw for Clamping Arm	1
DE207	Screw	4
DE208	Stabilizer	2
DE209	Nut for Sharpener Shoe Screw	2
DE210	Screw.#4-36x3/16Fillister Head	2
DE211	Intermediate Gear	1
DE212	Lower Gear Bracket with Cover	1
DE213	Wear Plate	2
DE214	Sping for Pulleyslide	2
DE215	R.H.Slide with Pully	1
DE216	Slide with Pulley	1
DE217	Gear on ScrewShaft <sup>24</sup>	1
DE218	Grease Plug	1
DE219	Bearing for Screw Shaft	1
DE220	Bearing for Intermediate Gear	1
DE221	Bearing for shaft Extension	2
DE222	Front Pulley tor Belt	1
DE223	Roll Pin	2
DE224	Neoprene Band for Pulley	2
DE225	R.H.Pre-set Sharpener Shoe(Only)	1
DE226	L.H.Pre-set Sharpener Shoe(Only)	1
DD227	Washer	4
DE228	R.H.Pre-set Sharpener Shoe	1
DE229	L.H.Pre-set Sharpener Shoe	1
DE230	Bushing for sharpener Shoe	2
DE231	R.H.Sharpener Shoe Spring	1
DE232	L.H.Sharpener Shoe Spring	1
DE233	Screw for Sharpener shoe	2
DE234	Shon Screw	1
DE235	Jam Nut	1
DE236	Belt	2

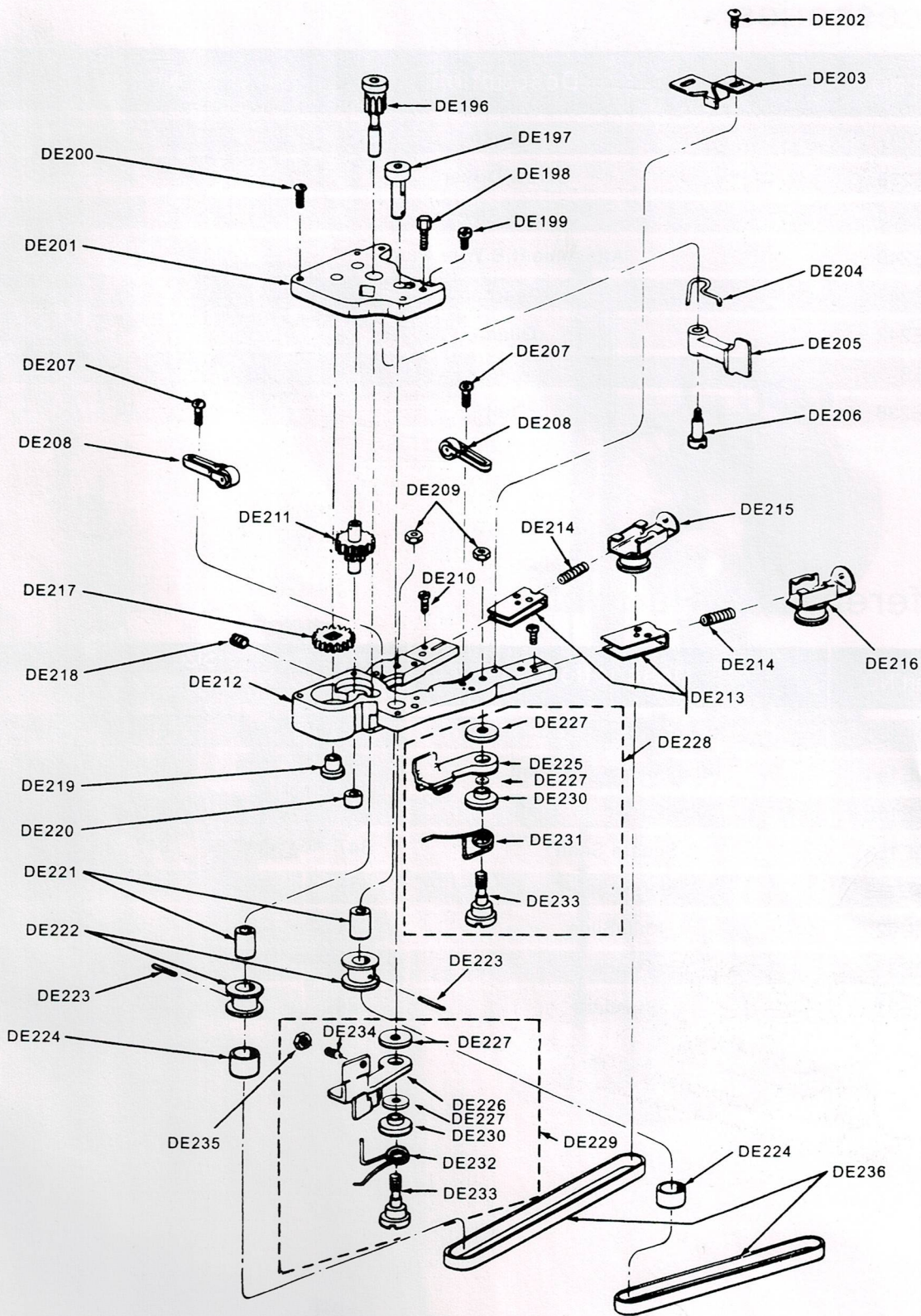

## Accessories

Part NO.	Description	NO.Req'd
DE237	Wrench	3
DE238	Screw Driver	2
DE239	Square Sleeve	1
DE240	Attachment & Wire Plug	1
DE241	Cleaner	1
DE242	Oilcan	1
DE8	Knife	1
DE236	Belt	10

## Different Size Parts List

Part NO.	Description	Size			
		12"	10"	8"	6"
DE150	Knife Guard Rod	414	364	314	264
DE154	Tube For Square Shaft	295	245	195	195
DE155	Tube For Screw Shaft	294	244	194	194
DE153	Square Shaft	347	297	247	197
DE113	Screw Shaft	419	369	319	269
DE92	KnifeSlide	319	269	219	169
DE8	Knife	344	294	244	194
DE91	Standard	324	274	224	174